

Coordinate Geometry

Question1

Let the area of the region $\{(x, y) : x - 2y + 4 \geq 0, x + 2y^2 \geq 0, x + 4y^2 \leq 8, y \geq 0\}$ be m/n , where m and n are coprime numbers.

Then $m + n$ is equal to ___

[27-Jan-2024 Shift 1]

Answer: 119

Solution:

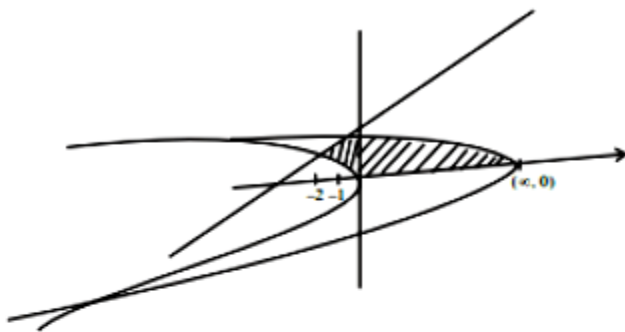

$$A = \int_0^1 [(8 - 4y^2) - (-2y^2)] dy +$$

$$\int_1^{3/2} [(8 - 4y^2) - (2y - 4)] dy$$

$$= \left[8y - \frac{2y^3}{3} \right]_0^1 + \left[12y - y^2 - \frac{4y^3}{3} \right]_1^{3/2} = \frac{107}{12} = \frac{m}{n}$$

$$\therefore m + n = 119$$

Question2

If the area of the region $\{(x, y) : 0 \leq y \leq \min\{2x, 6x - x^2\}\}$ is A , then $12A$ is equal to.....

[27-Jan-2024 Shift 2]

Answer: 304

Solution:

We have

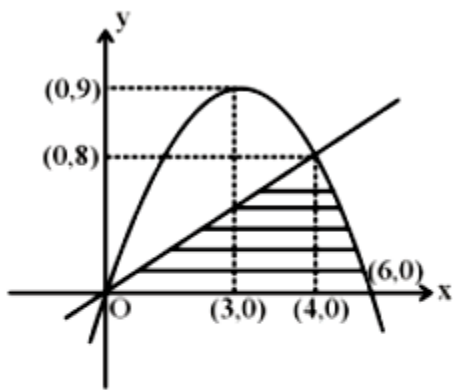

$$A = \frac{1}{2} \times 4 \times 8 + \int_4^6 (6x - x^2) dx$$

$$A = \frac{76}{3}$$

$$12A = 304$$

Question3

The area (in sq. units) of the part of circle $x^2 + y^2 = 169$ which is below the line $5x - y = 13$ is $\frac{\pi\alpha}{2\beta} - \frac{65}{2} + \frac{\alpha}{\beta} \sin^{-1}\left(\frac{12}{13}\right)$ where α, β are coprime numbers. Then $\alpha + \beta$ is equal to

[29-Jan-2024 Shift 1]

Answer: 171

Solution:

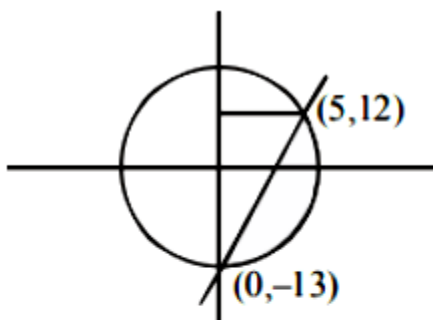

$$\text{Area} = \int_{-13}^{12} \sqrt{169 - y^2} dy - \frac{1}{2} \times 25 \times 5$$

$$= \frac{\pi}{2} \times \frac{169}{2} - \frac{65}{2} + \frac{169}{2} \sin^{-1} \frac{12}{13}$$

$$\therefore \alpha + \beta = 171$$

Question4

The area (in square units) of the region bounded by the parabola $y^2 = 4(x - 2)$ and the line $y = 2x - 8$

[30-Jan-2024 Shift 1]

Options:

A.

8

B.

9

C.

6

D.

7

Answer: B

Solution:

$$\text{Let } X = x - 2$$

$$y^2 = 4x, \quad y = 2(x + 2) - 8$$

$$y^2 = 4x, \quad y = 2x - 4$$

$$A = \int_{-2}^4 \frac{y^2}{4} - \frac{y+4}{2}$$

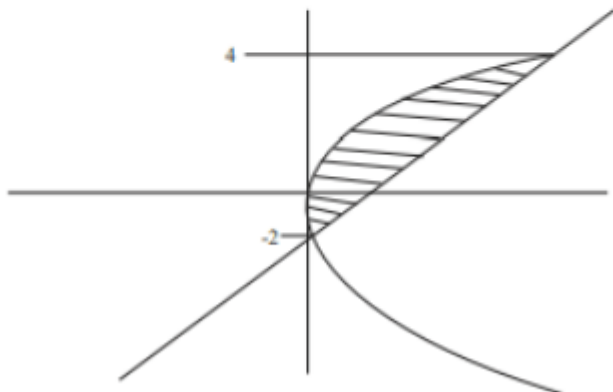

= 9

Question5

Let $Y = Y(X)$ be a curve lying in the first quadrant such that the area enclosed by the line $Y - y = Y'(x)(X - x)$ and the co-ordinate axes, where (x, y) is any point on the curve, is always $-y^2/2Y(x) + 1$, $Y'(x) \neq 0$. If $Y(1) = 1$, then $12Y(2)$ equals _____

[30-Jan-2024 Shift 2]

Answer: 20

Solution:

$$A = \frac{1}{2} \left(\frac{-y}{Y'(x)} + x \right) (y - xY'/x) = \frac{-y^2}{2Y'(x)} + 1$$

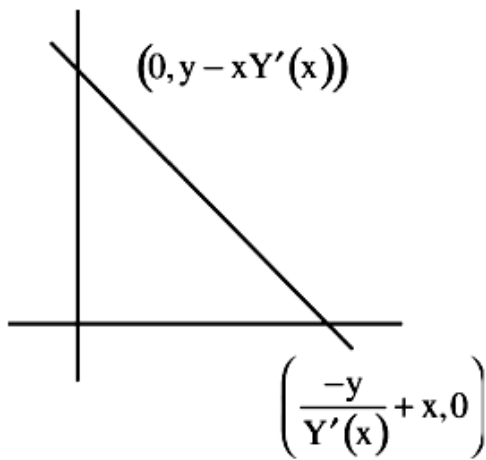

$$\Rightarrow (-y + xY'(x))(y - xY'(x)) = -y^2 + 2Y'(x)$$

$$-y^2 + xyY'(x) + xyY'(x) - x^2[Y'(x)]^2 = -y^2 + 2Y'(x)$$

$$2xy - x^2Y'(x) = 2$$

$$\frac{dy}{dx} = \frac{2xy - 2}{x^2}$$

$$\frac{dy}{dx} - \frac{2}{x}y = \frac{-2}{x^2}$$

$$\text{I.F.} = e^{-2 \ln x} = \frac{1}{x^2}$$

$$y \cdot \frac{1}{x^2} = \frac{2}{3}x^{-3} + c$$

$$\text{Put } x = 1, y = 1$$

$$1 = \frac{2}{3} + c \Rightarrow c = \frac{1}{3}$$

$$Y = \frac{2}{3} \cdot \frac{1}{X} + \frac{1}{3}X^2$$

$$\Rightarrow 12Y(2) = \frac{5}{3} \times 12 = 20$$

Question6

The area of the region enclosed by the parabola $(y - 2)^2 = x - 1$, the line $x - 2y + 4 = 0$ and the positive coordinate axes is _____

[30-Jan-2024 Shift 2]

Answer: 5

Solution:

$$\frac{x^2}{4} = x - 1$$

$$x^2 - 4x + 4 = 0$$

$$(x - 2)^2 = 0$$

$$x = 2$$

Enclose area (w.r.t. y-axis) = $\int_0^3 x dy - \text{Area of } \Delta$.

$$= \int_0^3 ((y - 2)^2 + 1) dy - \frac{1}{2} \times 1 \times 2$$

$$= \int_0^3 (y^2 - 4y + 5) dy - 1$$

$$= \left[\frac{y^3}{3} - 2y^2 + 5y \right]_0^3 - 1$$

$$= 9 - 18 + 15 - 1 = 5$$

Question7

The area of the region

$$\left\{ (x, y) : y^2 \leq 4x, x < 4, \frac{xy(x-1)(x-2)}{(x-3)(x-4)} > 0, x \neq 3 \right\}$$

is

[31-Jan-2024 Shift 1]

Options:

A.

16/3

B.

64/3

C.

8/3

D.

32/3

Answer: D

Solution:

$$y^2 \leq 4x, x < 4$$

$$\frac{x(x-1)(x-2)}{(x-3)(x-4)} > 0$$

Case - I : $y > 0$

$$\frac{x(x-1)(x-2)}{(x-3)(x-4)} > 0$$

$$x \in (0, 1) \cup (2, 3)$$

Case - II : $y < 0$

$$\frac{x(x-1)(x-2)}{(x-3)(x-4)} < 0, x \in (1, 2) \cup (3, 4)$$

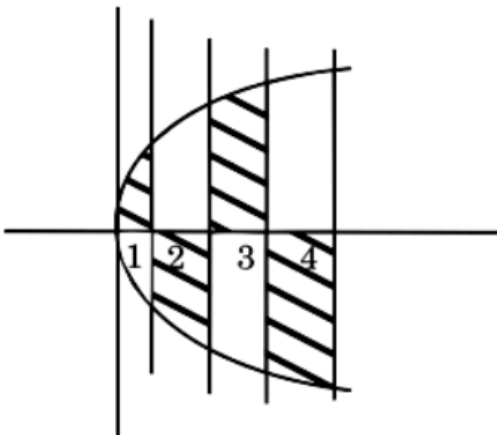

$$\text{Area} = 2 \int_0^4 \sqrt{x} \, dx$$

$$= 2 \cdot \frac{2}{3} [x^{3/2}]_0^4 = \frac{32}{3}$$

Question8

The area of the region enclosed by the parabola $y = 4x - x^2$ and $3y = (x - 4)^2$ is equal to

[31-Jan-2024 Shift 2]

Options:

A.

$32/9$

B.

4

C.

6

D.

$14/3$

Answer: C

Solution:



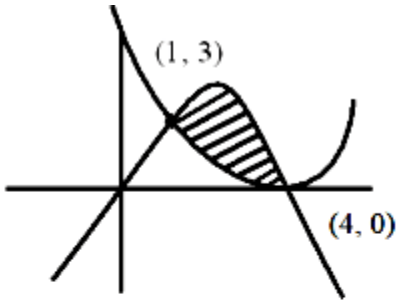

$$\text{Area} = \left| \int_1^4 \left[(4x - x^2) - \frac{(x-4)^2}{3} \right] dx \right|$$

$$\text{Area} = \left| \frac{4x^2}{2} - \frac{x^3}{3} - \frac{(x-4)^3}{9} \right|_1^4$$

$$= \left| \left(\frac{64}{2} - \frac{64}{3} - \frac{4}{2} + \frac{1}{3} - \frac{27}{9} \right) \right|$$

$$\Rightarrow (27 - 21) = 6$$

Question9

Four distinct points $(2k, 3k)$, $(1, 0)$, $(0, 1)$ and $(0, 0)$ lie on a circle for k equal to :

[27-Jan-2024 Shift 1]

Options:

A.

2/13

B.

3/13

C.

5/13

D.

1/13

Answer: C

Solution:

$(2k, 3k)$ will lie on circle whose diameter is AB

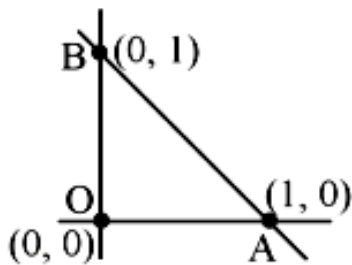

$$(x - 1)(x) + (y - 1)(y) = 0$$

$$x^2 + y^2 - x - y = 0 \dots\dots(i)$$

Satisfy $(2k, 3k)$ in (i)

$$(2k)^2 + (3k)^2 - 2k - 3k = 0$$

$$13k^2 - 5k = 0$$

$$k = 0, k = \frac{5}{13}$$

$$\text{hence } k = \frac{5}{13}$$

Question10

Consider a circle $(x - \alpha)^2 + (y - \beta)^2 = 50$, where $\alpha, \beta > 0$. If the circle touches the line $y + x = 0$ at the point P, whose distance from the origin is $4\sqrt{2}$ then $(\alpha + \beta)^2$ is equal to.....

[27-Jan-2024 Shift 2]

Answer: 100

Solution:

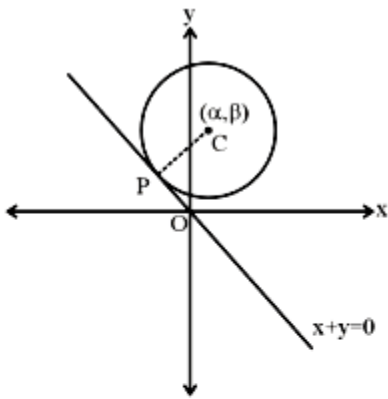

$$S : (x - \alpha)^2 + (y - \beta)^2 = 50$$

$$CP = r$$

$$\left| \frac{\alpha + \beta}{\sqrt{2}} \right| = 5\sqrt{2}$$

$$\Rightarrow (\alpha + \beta)^2 = 100$$

Question11



Equation of two diameters of a circle are $2x - 3y = 5$ and $3x - 4y = 7$.

The line joining the points $(-\frac{22}{7}, -4)$ and $(-\frac{1}{7}, 3)$ intersects the circle at only one point $P(\alpha, \beta)$. Then $17\beta - \alpha$ is equal to _____

[29-Jan-2024 Shift 1]

Answer: 2

Solution:

Centre of circle is $(1, -1)$

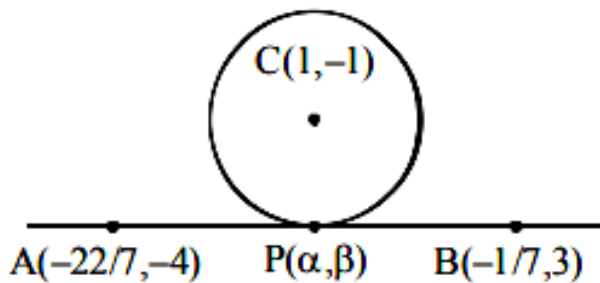

Equation of AB is $7x - 3y + 10 = 0$ (i)

Equation of CP is $3x + 7y + 4 = 0$ (ii)

Solving (i) and (ii)

$$\alpha = \frac{-41}{29}, \beta = \frac{1}{29}$$

$$\therefore 17\beta - \alpha = 2$$

Question12

If the circles $(x + 1)^2 + (y + 2)^2 = r^2$ and $x^2 + y^2 - 4x - 4y + 4 = 0$ intersect at exactly two distinct points, then

[30-Jan-2024 Shift 1]

Options:

A.

$$5 < r < 9$$

B.

$$0 < r < 7$$

C.

$$3 < r < 7$$

D.

$$1/2 < r < 7$$

Answer: C

Solution:

If two circles intersect at two distinct points

$$\Rightarrow |r_1 - r_2| < C_1 C_2 < r_1 + r_2$$

$$|r - 2| < \sqrt{9 + 16} < r + 2$$

$$|r - 2| < 5 \text{ and } r + 2 > 5$$

$$-5 < r - 2 < 5$$

$$r > 3 \dots\dots\dots(2)$$

$$-3 < r < 7 \dots\dots\dots(1)$$

From (1) and (2)

$$3 < r < 7$$

Question13

Consider two circles $C_1 : x^2 + y^2 = 25$ and $C_2 : (x - \alpha)^2 + y^2 = 16$, where $\alpha \in (5, 9)$. Let the angle between the two radii (one to each circle) drawn from one of the intersection points of C_1 and C_2 be

$\sin^{-1}(\sqrt{63}/8)$. If the length of common chord of C_1 and C_2 is β , then the value of $(\alpha\beta)^2$ equals _____

[30-Jan-2024 Shift 2]

Answer: 1575

Solution:

$$C_1 : x^2 + y^2 = 25, C_2 : (x - \alpha)^2 + y^2 = 16$$

$$5 < \alpha < 9$$

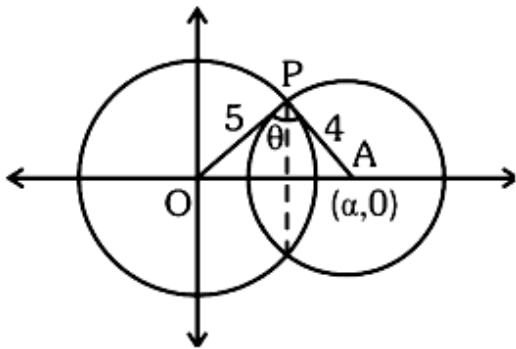

$$\theta = \sin^{-1}\left(\frac{\sqrt{63}}{8}\right)$$

$$\sin \theta = \frac{\sqrt{63}}{8}$$

$$\text{Area of } \triangle OAP = \frac{1}{2} \times \alpha \left(\frac{\beta}{2}\right) = \frac{1}{2} \times 5 \times 4 \sin \theta$$

$$\Rightarrow \alpha\beta = 40 \times \frac{\sqrt{63}}{8}$$

$$\alpha\beta = 5 \times \sqrt{63}$$

$$(\alpha\beta)^2 = 25 \times 63 = 1575$$

Question14

If one of the diameters of the circle $x^2 + y^2 - 10x + 4y + 13 = 0$ is a chord of another circle C, whose center is the point of intersection of the lines $2x + 3y = 12$ and $3x - 2y = 5$, then the radius of the circle C is

[31-Jan-2024 Shift 1]

Options:

A.

$\sqrt{20}$

B.

4

C.

6

D.

$3\sqrt{2}$

Answer: C

Solution:

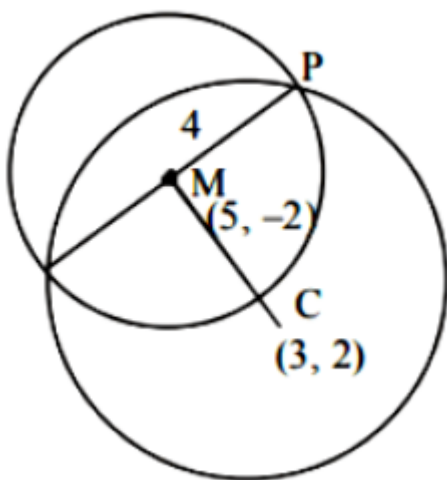

$$2x + 3y = 12$$

$$3x - 2y = 5$$

$$13x = 39$$

$$x = 3, y = 2$$

Center of given circle is $(5, -2)$

$$\text{Radius } \sqrt{25 + 4 - 13} = 4$$

$$\therefore \text{CM} = \sqrt{4 + 16} = 5\sqrt{2}$$

$$\therefore \text{CP} = \sqrt{16 + 20} = 6$$

Question15

Let a variable line passing through the centre of the circle $x^2 + y^2 - 16x - 4y = 0$, meet the positive co-ordinate axes at the point A and B. Then the minimum value of $OA + OB$, where O is the origin, is equal to

[31-Jan-2024 Shift 2]

Options:

A.

12

B.

18

C.

20

D.

24

Answer: B

Solution:

$$(y - 2) = m(x - 8)$$

\Rightarrow x -intercept

$$\Rightarrow \left(\frac{-2}{m} + 8 \right)$$

\Rightarrow y -intercept

$$\Rightarrow (-8m + 2)$$

$$\Rightarrow OA + OB = \frac{-2}{m} + 8 - 8m + 2$$

$$f'(m) = \frac{2}{m^2} - 8 = 0$$

$$\Rightarrow m^2 = \frac{1}{4}$$

$$\Rightarrow m = \frac{-1}{2}$$

$$\Rightarrow f\left(\frac{-1}{2}\right) = 18$$

\Rightarrow Minimum = 18

Question16

The length of the chord of the ellipse $\frac{x^2}{25} + \frac{y^2}{16} = 1$, whose mid point is $(1, 2/5)$, is equal to :

[27-Jan-2024 Shift 1]

Options:

A.

$$\sqrt{1691/5}$$

B.

$$\sqrt{2009/5}$$

C.

$$\sqrt{1741/5}$$

D.

$$\sqrt{1541/5}$$

Answer: A

Solution:

Equation of chord with given middle point.

$$T = S_1$$

$$\frac{x}{25} + \frac{y}{40} = \frac{1}{25} + \frac{1}{100}$$

$$\frac{8x+5y}{200} = \frac{8+2}{200}$$

$$y = \frac{10-8x}{5} \dots\dots(i)$$

$$\frac{x^2}{25} + \frac{(10-8x)^2}{400} = 1 \quad (\text{put in original equation})$$

$$\frac{16x^2 + 100 + 64x^2 - 160x}{400} = 1$$

$$4x^2 - 8x - 15 = 0$$

$$x = \frac{8 \pm \sqrt{304}}{8}$$

$$x_1 = \frac{8 + \sqrt{304}}{8}; x_2 = \frac{8 - \sqrt{304}}{8}$$

$$\text{Similarly, } y = \frac{10 - 18 \pm \sqrt{304}}{5} = \frac{2 \pm \sqrt{304}}{5}$$

$$y_1 = \frac{2 - \sqrt{304}}{5}; y_2 = \frac{2 + \sqrt{304}}{5}$$

$$\begin{aligned} \text{Distance} &= \sqrt{(x_1 - x_2)^2 + (y_1 - y_2)^2} \\ &= \sqrt{\frac{4 \times 304}{64} + \frac{4 \times 304}{25}} = \frac{\sqrt{1691}}{5} \end{aligned}$$

Question17

If the points of intersection of two distinct conics $x^2 + y^2 = 4b$ and $\frac{x^2}{16} + \frac{y^2}{b^2} = 1$ lie on the curve $y^2 = 3x^2$, then $3\sqrt{3}$ times the area of the rectangle formed by the intersection points is __

[29-Jan-2024 Shift 1]

Answer: 432

Solution:

Putting $y^2 = 3x^2$ in both the conics

We get $x^2 = b$ and $\frac{b}{16} + \frac{3}{b} = 1$

$\Rightarrow b = 4, 12$ ($b = 4$ is rejected because curves coincide)

$\therefore b = 12$

Hence points of intersection are

$(\pm\sqrt{12}, \pm 6) \Rightarrow$ area of rectangle = 432

Question18

If the length of the minor axis of ellipse is equal to half of the distance between the foci, then the eccentricity of the ellipse is :

[30-Jan-2024 Shift 1]

Options:

A.

$\sqrt{5/3}$

B.

$\sqrt{3/2}$

C.

$1/\sqrt{3}$

D.

$2/\sqrt{5}$

Answer: D

Solution:

$$2b = ae$$

$$\frac{b}{a} = \frac{e}{2}$$

$$e = \sqrt{1 - \frac{e^2}{4}}$$

$$e = \frac{2}{\sqrt{5}}$$

Question19

Let $A(\alpha, 0)$ and $B(0, \beta)$ be the points on the line $5x + 7y = 50$. Let the point P divide the line segment AB internally in the ratio $7 : 3$. Let $3x -$

$25 = 0$ be a directrix of the ellipse $E: \frac{x^2}{a^2} + \frac{y^2}{b^2} = 1$ and the corresponding focus be S . If from S , the perpendicular on the x -axis passes through P , then the length of the latus rectum of E is equal to

[30-Jan-2024 Shift 2]

Options:

A.

$25/3$

B.

$32/9$

C.

$25/9$

D.

32/5

Answer: D

Solution:

$$\left. \begin{array}{l} A = (10, 0) \\ B = \left(0, \frac{50}{7}\right) \end{array} \right\} P = (3, 5)$$

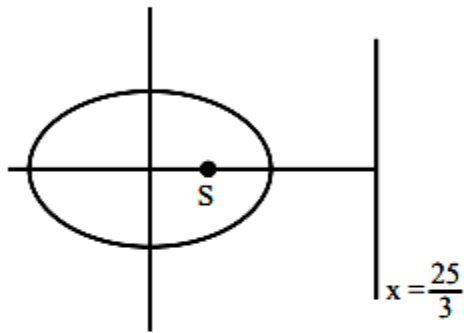

$$ae = 3$$

$$\frac{a}{e} = \frac{25}{3}$$

$$a = 5$$

$$b = 4$$

$$\text{Length of LR} = \frac{2b^2}{a} = \frac{32}{5}$$

Question20

Let P be a parabola with vertex (2, 3) and directrix $2x + y = 6$. Let an ellipse E: $\frac{x^2}{a^2} + \frac{y^2}{b^2} = 1, a > b$ of eccentricity $1/\sqrt{2}$ pass through the focus of the parabola P. Then the square of the length of the latus rectum of E, is

[31-Jan-2024 Shift 2]

Options:

A.

$385/8$

B.

$347/8$

C.

$512/25$

D.

$656/25$

Answer: D

Solution:

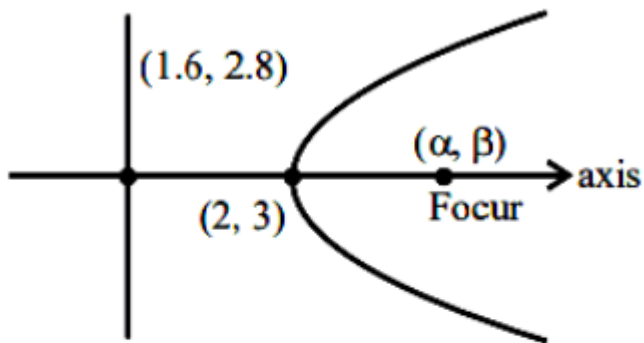

$$\text{Slope of axis} = \frac{1}{2}$$

$$y - 3 = \frac{1}{2}(x - 2)$$

$$\Rightarrow 2y - 6 = x - 2$$

$$\Rightarrow 2y - x - 4 = 0$$

$$2x + y - 6 = 0$$

$$4x + 2y - 12 = 0$$

$$\alpha + 1.6 = 4 \Rightarrow \alpha = 2.4$$

$$\beta + 2.8 = 6 \Rightarrow \beta = 3.2$$

Ellipse passes through (2.4, 3.2)

$$\Rightarrow \frac{\left(\frac{24}{10}\right)^2}{a^2} + \frac{\left(\frac{32}{10}\right)^2}{b^2} = 1 \dots\dots\dots(1)$$

$$\text{Also } 1 - \frac{b^2}{a^2} = \frac{1}{2} = \frac{b^2}{a^2} = \frac{1}{2}$$

$$\Rightarrow a^2 = 2b^2$$

$$\text{Put in (1)} \Rightarrow b^2 = \frac{328}{25}$$

$$\Rightarrow \left(\frac{2b^2}{a}\right)^2 = \frac{4b^2}{a^2} \times b^2 = 4 \times \frac{1}{2} \times \frac{328}{25} = \frac{656}{25}$$

Question21

Let e_1 be the eccentricity of the hyperbola $\frac{x^2}{16} - \frac{y^2}{9} = 1$ and e_2 be the eccentricity of the ellipse $\frac{x^2}{a^2} + \frac{y^2}{b^2} = 1, a > b,$ which passes through the foci of

the hyperbola. If $e_1 e_2 = 1$, then the length of the chord of the ellipse parallel to the x-axis and passing through $(0, 2)$ is :

[27-Jan-2024 Shift 2]

Options:

A.

$4\sqrt{5}$

B.

$8\sqrt{5/3}$

C.

$10\sqrt{5/3}$

D.

$3\sqrt{5}$

Answer: C

Solution:

$$H : \frac{x^2}{16} - \frac{y^2}{9} = 1 \quad e_1 = \frac{5}{4}$$

$$\therefore e_1 e_2 = 1 \Rightarrow e_2 = \frac{4}{5}$$

Also, ellipse is passing through $(\pm 5, 0)$

$$\therefore a = 5 \text{ and } b = 3$$

$$E : \frac{x^2}{25} + \frac{y^2}{9} = 1$$

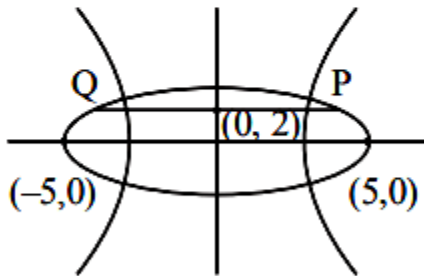

End point of chord are $(\pm \frac{5\sqrt{5}}{3}, 2)$

$$\therefore L_{PQ} = \frac{10\sqrt{5}}{3}$$

Question22

Let the latus rectum of the hyperbola $\frac{x^2}{9} - \frac{y^2}{b^2} = 1$ subtend an angle of $\pi/3$ at the centre of the hyperbola. If b^2 is equal to $l/m (1 + \sqrt{n})$, where l and m are co-prime numbers, then $l^2 + m^2 + n^2$ is equal to _____

[30-Jan-2024 Shift 1]

Answer: 182

Solution:

LR subtends 60° at centre

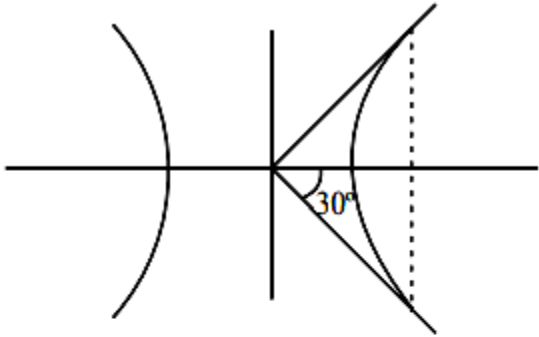

$$\Rightarrow \tan 30^\circ = \frac{b^2/a}{ae} = \frac{b^2}{a^2e} = \frac{1}{\sqrt{3}}$$

$$\Rightarrow e = \frac{\sqrt{3}b^2}{9}$$

$$\text{Also, } e^2 = 1 + \frac{b^2}{9} \Rightarrow 1 + \frac{b^2}{9} = \frac{3b^4}{81}$$

$$\Rightarrow b^4 = 3b^2 + 27$$

$$\Rightarrow b^4 - 3b^2 - 27 = 0$$

$$\Rightarrow b^2 = \frac{3}{2}(1 + \sqrt{13})$$

$$\Rightarrow \ell = 3, m = 2, n = 13$$

$$\Rightarrow \ell^2 + m^2 + n^2 = 182$$

Question23

Let P be a point on the hyperbola H : $\frac{x^2}{9} - \frac{y^2}{4} = 1$, in the first quadrant such that the area of triangle formed by P and the two foci of H is $2\sqrt{13}$. Then, the square of the distance of P from the origin is

[30-Jan-2024 Shift 2]

Options:

A.

18

B.

26

C.

22

D.

20

Answer: C

Solution:

$$\frac{x^2}{9} - \frac{y^2}{4} = 1$$

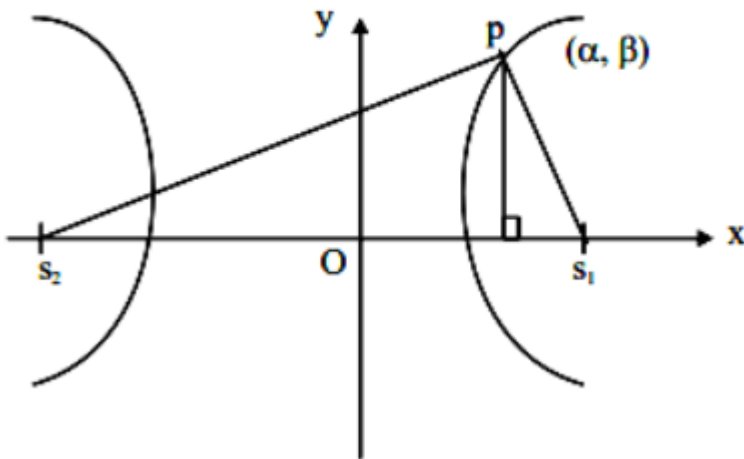

$$a^2 = 9, b^2 = 4$$

$$b^2 = a^2(e^2 - 1) \Rightarrow e^2 = 1 + \frac{b^2}{a^2}$$

$$e^2 = 1 + \frac{4}{9} = \frac{13}{9}$$

$$e = \frac{\sqrt{13}}{3} \Rightarrow s_1 s_2 = 2ae = 2 \times 3 \times \sqrt{\frac{13}{3}} = 2\sqrt{13}$$

$$\text{Area of } \Delta PS_1S_2 = \frac{1}{2} \times \beta \times S_1S_2 = 2\sqrt{13}$$

$$\Rightarrow \frac{1}{2} \times \beta \times (2\sqrt{13}) = 2\sqrt{13} \Rightarrow \beta = 2$$

$$\frac{a^2}{9} - \frac{\beta^2}{4} = 1 \Rightarrow \frac{a^2}{9} - 1 = 1 \Rightarrow a^2 = 18 \Rightarrow a = 3\sqrt{2}$$

$$\begin{aligned} \text{Distance of P from origin} &= \sqrt{a^2 + \beta^2} \\ &= \sqrt{18 + 4} = \sqrt{22} \end{aligned}$$

Question24

If the foci of a hyperbola are same as that of the ellipse $\frac{x^2}{9} + \frac{y^2}{25} = 1$ and the eccentricity of the hyperbola is $\frac{15}{8}$ times the eccentricity of the ellipse, then the smaller focal distance of the point $(\sqrt{2}, \frac{14}{3} \sqrt{\frac{2}{5}})$ on the hyperbola, is equal to



[31-Jan-2024 Shift 1]

Options:

A.

$$7 \sqrt{\frac{2}{5} - \frac{8}{3}}$$

B.

$$14 \sqrt{\frac{2}{5} - \frac{4}{3}}$$

C.

$$14 \sqrt{\frac{2}{5} - \frac{16}{3}}$$

D.

$$7 \sqrt{\frac{2}{5} + \frac{8}{3}}$$

Answer: A

Solution:

$$\frac{x^2}{9} + \frac{y^2}{25} = 1$$

$$a = 3, b = 5$$

$$e = \sqrt{1 - \frac{9}{25}} = \frac{4}{5}$$

$$\therefore \text{foci} = (0, \pm be) = (0, \pm 4)$$

$$\therefore e_H = \frac{4}{5} \times \frac{15}{8} = \frac{3}{2}$$

Let equation hyperbola

$$\frac{x^2}{A^2} - \frac{y^2}{B^2} = -1$$

$$\therefore B \cdot e_H = 4$$

$$\therefore B = \frac{8}{3}$$

$$\therefore A^2 = B^2(e_H^2 - 1) = \frac{64}{9} \left(\frac{9}{4} - 1 \right) \therefore A^2 = \frac{80}{9}$$

$$\therefore \frac{x^2}{\frac{80}{9}} - \frac{y^2}{\frac{64}{9}} = -1$$

$$\text{Directrix : } y = \pm \frac{B}{e_H} = \pm \frac{16}{9}$$

$$PS = e \cdot PM = \frac{3}{2} \left| \frac{14}{3} \cdot \sqrt{\frac{2}{5}} - \frac{16}{9} \right|$$

$$= 7 \sqrt{\frac{2}{5}} - \frac{8}{3}$$

Question 25

Let the foci and length of the latus rectum of an ellipse

$$\frac{x^2}{a^2} + \frac{y^2}{b^2} = 1, a > b \text{ be } (\pm 5, 0) \text{ and } \sqrt{50},$$

respectively. Then, the square of the

eccentricity of the hyperbola $\frac{x^2}{b^2} - \frac{y^2}{a^2 b^2} = 1$ equals



[31-Jan-2024 Shift 1]

Answer: 51

Solution:

$$\text{foci} = (\pm 5, 0); \frac{2b^2}{a} = \sqrt{50}$$

$$a = 5 \quad b^2 = \frac{5\sqrt{2}a}{2}$$

$$b^2 = a^2(1 - e^2) = \frac{5\sqrt{2}a}{2}$$

$$\Rightarrow a(1 - e^2) = \frac{5\sqrt{2}}{2}$$

$$\Rightarrow \frac{5}{e}(1 - e^2) = \frac{5\sqrt{2}}{2}$$

$$\Rightarrow \sqrt{2} - \sqrt{2}e^2 = e$$

$$\Rightarrow \sqrt{2}e^2 + e - \sqrt{2} = 0$$

$$\Rightarrow \sqrt{2}e^2 + 2e - e - \sqrt{2} = 0$$

$$\Rightarrow \sqrt{2}e(e + \sqrt{2}) - 1(1 + \sqrt{2}) = 0$$

$$\Rightarrow (e + \sqrt{2})(\sqrt{2}e - 1) = 0$$

$$\therefore e \neq -\sqrt{2}; e = \frac{1}{\sqrt{2}}$$

$$\frac{x^2}{b^2} - \frac{y^2}{a^2 b^2} = 1$$

$$a = 5\sqrt{2}$$

$$b = 5$$

$$a^2 b^2 = b^2 (e_1^2 - 1) \Rightarrow e_1^2 = 51$$

Question 26

If the shortest distance of the parabola $y^2 = 4x$ from the centre of the circle $x^2 + y^2 - 4x - 16y + 64 = 0$ is d , then d^2 is equal to :

[27-Jan-2024 Shift 1]

Options:

A.

16

B.

24

C.

20

D.

36

Answer: C

Solution:

Equation of normal to parabola

$$y = mx - 2m - m^3$$

this normal passing through center of circle (2, 8)

$$8 = 2m - 2m - m^3$$

$$m = -2$$

So point P on parabola $\Rightarrow (am^2, -2am) = (4, 4)$

And C = (2, 8)

$$PC = \sqrt{4 + 16} = \sqrt{20}$$

$$d^2 = 20$$

Question27

Let $P(\alpha, \beta)$ be a point on the parabola $y^2 = 4x$. If P also lies on the chord of the parabola $x^2 = 8y$ whose mid point is $(1, 5/4)$. Then $(\alpha - 28)(\beta - 8)$ is equal to _____

[29-Jan-2024 Shift 2]

Answer: 192

Solution:

Parabola is $x^2 = 8y$

Chord with mid point (x_1, y_1) is $T = S_1$

$$\therefore xx_1 - 4(y + y_1) = x_1^2 - 8y_1$$

$$\therefore (x_1, y_1) = \left(1, \frac{5}{4}\right)$$

$$\Rightarrow x - 4\left(y + \frac{5}{4}\right) = 1 - 8 \times \frac{5}{4} = -9$$

$$\therefore x - 4y + 4 = 0 \dots\dots(i)$$

(α, β) lies on (i) & also on $y^2 = 4x$

$$\therefore \alpha - 4\beta + 4 = 0 \dots\dots(ii)$$

$$\& \beta^2 = 4\alpha \dots\dots(iii)$$

Solving (ii) & (iii)

$$\beta^2 = 4(4\beta - 4) \Rightarrow \beta^2 - 16\beta + 16 = 0$$

$$\therefore \beta = 8 \pm 4\sqrt{3} \text{ and } \alpha = 4\beta - 4 = 28 \pm 16\sqrt{3}$$

$$\therefore (\alpha, \beta) = (28 + 16\sqrt{3}, 8 + 4\sqrt{3}) \text{ \& } (28 - 16\sqrt{3}, 8 - 4\sqrt{3})$$

$$\therefore (\alpha - 28)(\beta - 8) = (\pm 16\sqrt{3})(\pm 4\sqrt{3})$$

$$= 192$$

Question28

The maximum area of a triangle whose one vertex is at $(0, 0)$ and the other two vertices lie on the curve $y = -2x^2 + 54$ at points (x, y) and $(-x, y)$ where $y > 0$ is :

[30-Jan-2024 Shift 1]

Options:

A.

88

B.

122

C.

92

D.

108

Answer: D

Solution:

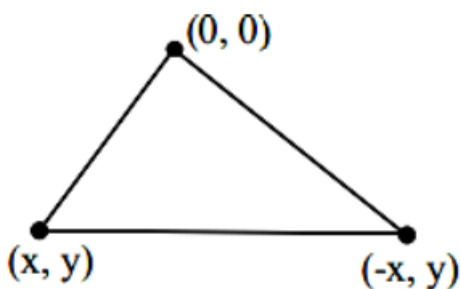

Area of Δ

$$= \frac{1}{2} \begin{vmatrix} 0 & 0 & 1 \\ x & y & 1 \\ -x & y & 1 \end{vmatrix}$$

$$\Rightarrow \left| \frac{1}{2}(xy + xy) \right| = |xy|$$

$$\text{Area } (\Delta) = |xy| = |x(-2x^2 + 54)|$$

$$\frac{d(\Delta)}{dx} = |(-6x^2 + 54)| \Rightarrow \frac{d\Delta}{dx} = 0 \text{ at } x = 3$$

$$\text{Area} = 3(-2 \times 9 + 54) = 108$$

Question29

Let $C : x^2 + y^2 = 4$ and $C' : x^2 + y^2 - 4\lambda x + 9 = 0$ be two circles. If the set of all values of λ so that the circles C and C' intersect at two distinct points, is $R - [a, b]$, then the point $(8a + 12, 16b - 20)$ lies on the curve :

[1-Feb-2024 Shift 1]

Options:

A.

$$x^2 + 2y^2 - 5x + 6y = 3$$

B.

$$5x^2 - y = -11$$

C.

$$x^2 - 4y^2 = 7$$

D.

$$6x^2 + y^2 = 42$$

Answer: D

Solution:

$$x^2 + y^2 = 4$$

$$C(0, 0)$$

$$r_1 = 2$$

$$C'(2\lambda, 0) \quad r_2 = \sqrt{4\lambda^2 - 9}$$

$$|r_1 - r_2| < CC' < |r_1 + r_2|$$

$$2 - \sqrt{4\lambda^2 - 9} < |2\lambda| < 2 + \sqrt{4\lambda^2 - 9}$$

$$4 + 4\lambda^2 - 9 - 4\sqrt{4\lambda^2 - 9} < 4\lambda^2$$

True $\lambda \in \mathbb{R} \dots (1)$

$$4\lambda^2 < 4 + 4\lambda^2 - 9 + 4\sqrt{4\lambda^2 - 9}$$

$$5 < 4\sqrt{4\lambda^2 - 9} \quad \text{and} \quad \lambda^2 \geq \frac{9}{4}$$

$$\frac{25}{16} < 4\lambda^2 - 9 \quad \lambda \in \left(-\infty, -\frac{3}{2}\right] \cup \left[\frac{3}{2}, \infty\right)$$

$$\frac{169}{64} < \lambda^2$$

$$\lambda \in \left(-\infty, -\frac{13}{8}\right) \cup \left(\frac{13}{8}, \infty\right) \dots\dots\dots(2)$$

from (1) and (2) $\lambda \in$

$$\lambda \in \left(-\infty, -\frac{13}{8}\right) \cup \left(\frac{13}{8}, \infty\right) \Rightarrow \mathbb{R} - \left[-\frac{13}{8}, \frac{13}{8}\right]$$

as per question $a = -\frac{13}{8}$ and $b = \frac{13}{8}$

required point is $(-1, 6)$ with satisfies option (4)

Question30

Let the line $L : \sqrt{2}x + y = \alpha$ pass through the point of the intersection P (in the first quadrant) of the circle $x^2 + y^2 = 3$ and the parabola $x^2 = 2y$. Let the line L touch two circles C_1 and C_2 of equal radius $2\sqrt{3}$. If

the centres Q_1 and Q_2 of the circles C_1 and C_2 lie on the y-axis, then the square of the area of the triangle PQ_1Q_2 is equal to _____

[1-Feb-2024 Shift 1]

Answer: 72

Solution:

$$x^2 + y^2 = 3 \text{ and } x^2 = 2y$$

$$y^2 + 2y - 3 = 0 \Rightarrow (y+3)(y-1) = 0$$

$$y = -3 \text{ or } y = 1$$

$$y = 1 \Rightarrow x = \sqrt{2} \Rightarrow P(\sqrt{2}, 1)$$

p lies on the line

$$\sqrt{2}x + y = \alpha$$

$$\sqrt{2}(\sqrt{2}) + 1 = \alpha$$

$$\alpha = 3$$

For circle C_1

Q_1 lies on y axis

Let $Q_1(0, \alpha)$ coordinates

$$R_1 = 2\sqrt{3} \text{ (Given)}$$

Line L act as tangent

Apply $P = r$ (condition of tangency)

$$\Rightarrow \left| \frac{\alpha - 3}{\sqrt{3}} \right| = 2\sqrt{3}$$

$$\Rightarrow |\alpha - 3| = 6$$

$$\alpha - 3 = 6 \text{ or } \alpha - 3 = -6$$

$$\Rightarrow \alpha = 9 \text{ or } \alpha = -3$$

$$\Delta PQ_1Q_2 = \frac{1}{2} \begin{vmatrix} \sqrt{2} & 1 & 1 \\ 0 & 9 & 1 \\ 0 & -3 & 1 \end{vmatrix}$$

$$= \frac{1}{2}(\sqrt{2}(12)) = 6\sqrt{2}$$

$$(\Delta PQ_1Q_2)^2 = 72$$

Get More Learning Materials Here :



CLICK HERE 



www.studentbro.in

Question31

Let the locus of the mid points of the chords of circle $x^2 + (y - 1)^2 = 1$ drawn from the origin intersect the line $x + y = 1$ at P and Q. Then, the length of PQ is :

[1-Feb-2024 Shift 2]

Options:

A.

$1/\sqrt{2}$

B.

$\sqrt{2}$

C.

$1/2$

D.

1

Answer: A

Solution:

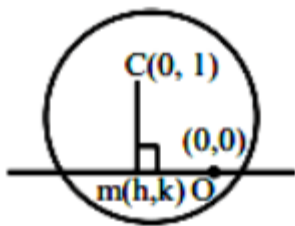

$$m_{OM} \cdot m_{CM} = -1$$

$$\frac{k}{h} \cdot \frac{k-1}{h} = -1$$

$$\therefore \text{locus is } x^2 + y(y-1) = 0$$

$$x^2 + y^2 - y = 0$$

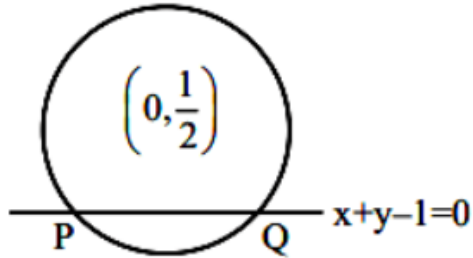

$$p = \left| \frac{1/2}{\sqrt{2}} \right| \quad p = \frac{1}{2\sqrt{2}}$$

$$PQ = 2\sqrt{r^2 - p^2}$$

$$= 2\sqrt{\frac{1}{4} - \frac{1}{8}} = \frac{1}{\sqrt{2}}$$

Question32

The area enclosed by the curves $xy + 4y = 16$ and $x + y = 6$ is equal to :

[1-Feb-2024 Shift 1]

Options:

A.

$$28 - 30\log_e 2$$

B.

$$30 - 28\log_e 2$$

C.

$$30 - 32\log_e 2$$

D.

$$32 - 30\log_e 2$$

Answer: C

Solution:

$$xy + 4y = 16$$

$$y(x+4) = 16 \dots\dots\dots(1)$$

$$x+y = 6 \dots\dots\dots(2)$$

on solving, (1) & (2)

we get $x = 4, x = -2$

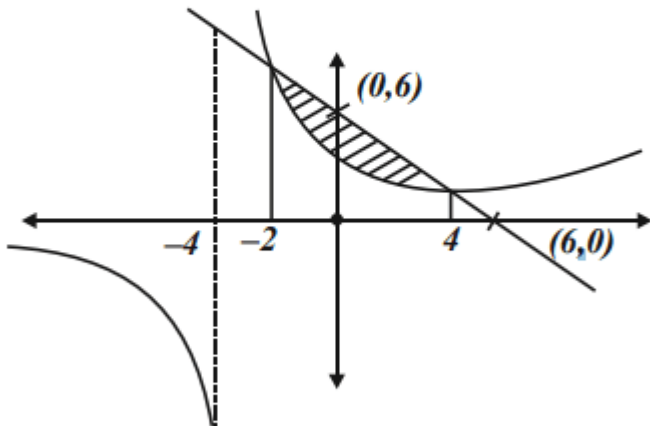

$$\begin{aligned} \text{Area} &= \int_{-2}^4 \left((6-x) - \left(\frac{16}{x+4} \right) \right) dx \\ &= 30 - 32 \ln 2 \end{aligned}$$

Question33

The sum of squares of all possible values of k , for which area of the region bounded by the parabolas $2y^2 = kx$ and $ky^2 = 2(y - x)$ is

maximum, is equal to :

[1-Feb-2024 Shift 2]

Answer: None

Solution:

$$ky^2 = 2(y-x) \quad 2y^2 = kx$$

Point of intersection \rightarrow

$$ky^2 = \left(y - \frac{2y^2}{k}\right)$$

$$y = 0 \quad ky = 2\left(1 - \frac{2y}{k}\right)$$

$$ky + \frac{4y}{k} = 2$$

$$y = \frac{2}{k + \frac{4}{k}} = \frac{2k}{k^2 + 4}$$

$$\begin{aligned} A &= \int_0^{\frac{2k}{k^2+4}} \left(\left(y - \frac{ky^2}{2}\right) - \left(\frac{2y^2}{k}\right) \right) \cdot dy \\ &= \frac{y^2}{2} - \left(\frac{k}{2} + \frac{2}{k}\right) \cdot \frac{y^3}{3} \Big|_0^{\frac{2k}{k^2+4}} \\ &= \left(\frac{2k}{k^2+4}\right)^2 \left[\frac{1}{2} - \frac{k^2+4}{2k} \times \frac{1}{3} \times \frac{2k}{k^2+4} \right] \\ &= \frac{1}{6} \times 4 \times \left(\frac{1}{k + \frac{4}{k}}\right)^2 \end{aligned}$$

$$A \cdot M \geq G \cdot M \quad \frac{\left(k + \frac{4}{k}\right)}{2} \geq 2$$

$$k + \frac{4}{k} \geq 4$$

Area is maximum when $k = \frac{4}{k}$

$$k = 2, -2$$

Question34

Let P be a point on the ellipse $\frac{x^2}{9} + \frac{y^2}{4} = 1$. Let the line passing through P and parallel to y-axis meet the circle $x^2 + y^2 = 9$ at point Q such that P and Q are on the same side of the x-axis. Then, the eccentricity of the locus of the point R on PQ such that $PR : RQ = 4:3$ as P moves on the ellipse, is :

[1-Feb-2024 Shift 2]

Options:

A.

$11/19$

B.

$13/21$

C.

$\sqrt{139}/23$

D.

$\sqrt{13}/7$

Answer: D

Solution:

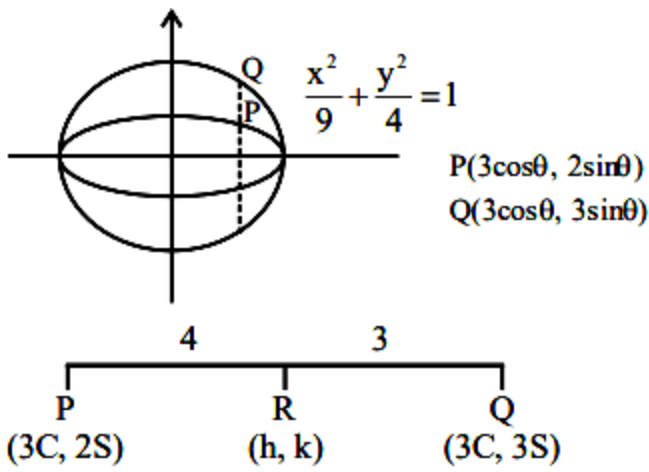

$$h = 3 \cos \theta$$

$$k = \frac{18}{7} \sin \theta$$

$$\therefore \text{locus} = \frac{x^2}{9} + \frac{49y^2}{324} = 1$$

$$e = \sqrt{1 - \frac{324}{49 \times 9}} = \frac{\sqrt{117}}{21} = \frac{\sqrt{13}}{7}$$

Question35

For $0 < \theta < \pi/2$, if the eccentricity of the hyperbola $x^2 - y^2 \operatorname{cosec}^2 \theta = 5$ is $\sqrt{7}$ times eccentricity of the ellipse $x^2 \operatorname{cosec}^2 \theta + y^2 = 5$, then the value of θ is :

[1-Feb-2024 Shift 1]

Options:

A.

$\pi/6$

B.

$5\pi/12$

C.

$\pi/3$

D.

$\pi/4$

Answer: C

Solution:

$$e_h = \sqrt{1 + \sin^2 \theta}$$

$$e_c = \sqrt{1 - \sin^2 \theta}$$

$$e_h = \sqrt{7} e_c$$

$$1 + \sin^2 \theta = 7(1 - \sin^2 \theta)$$

$$\sin^2 \theta = \frac{6}{8} = \frac{3}{4}$$

$$\sin \theta = \frac{\sqrt{3}}{2}$$

$$\theta = \frac{\pi}{3}$$

Question36

Let $\frac{x^2}{a^2} + \frac{y^2}{b^2} = 1, a > b$ be an ellipse, whose eccentricity is $1/\sqrt{2}$ and the length of the latus rectum is $\sqrt{14}$. Then the square of the eccentricity of

$\frac{x^2}{a^2} - \frac{y^2}{b^2} = 1$ is :

[1-Feb-2024 Shift 1]

Options:

A.

3

B.

7/2

C.

3/2

D.

5/2

Answer: C

Solution:

$$e = \frac{1}{\sqrt{2}} = \sqrt{1 - \frac{b^2}{a^2}} \Rightarrow \frac{1}{2} = 1 - \frac{b^2}{a^2}$$

$$\frac{2b^2}{a} = 14$$

$$e_H = \sqrt{1 + \frac{b^2}{a^2}} = \sqrt{1 + \frac{1}{2}} = \sqrt{\frac{3}{2}}$$

$$(e_H)^2 = \frac{3}{2}$$

Question37

Three points $O(0, 0)$, $P(a, a^2)$, $Q(-b, b^2)$, $a > 0$, $b > 0$, are on the parabola $y = x^2$. Let S_1 be the area of the region bounded by the line PQ and the parabola, and S_2 be the area of the triangle OPQ . If the minimum value of S_1/S_2 is m/n , $\gcd(m, n) = 1$, then $m + n$ is

[1-Feb-2024 Shift 2]

Answer: 7

Solution:

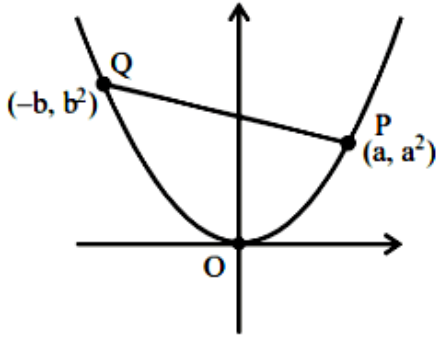

$$S_2 = \frac{1}{2} \begin{vmatrix} 0 & 0 & 1 \\ a & a^2 & 1 \\ -b & b^2 & 1 \end{vmatrix} = \frac{1}{2}(ab + a^2b)$$

$$\text{PQ: } y - a^2 = \frac{a^2 - b^2}{a + b}(x - a)$$

$$y - a^2 = (a - b)x - (a - b)a$$

$$y = (a - b)x + ab$$

$$S_1 = \int_{-b}^a ((a - b)x + ab - x^2) dx$$

$$= (a - b) \frac{x^2}{2} + (ab)x - \frac{x^3}{3} \Big|_{-b}^a$$

$$= \frac{(a - b)^2(a + b)}{2} + ab(a + b) - \frac{(a^3 + b^3)}{3}$$

$$\frac{S_1}{S_2} = \frac{\frac{(a - b)^2}{2} + ab - \frac{(a^2 + b^2 - ab)}{3}}{\frac{ab}{2}}$$

$$= \frac{3(a - b)^2 + 6ab - 2(a^2 + b^2 - ab)}{3ab}$$

$$= \frac{1}{3} \left[\frac{a}{b} + \frac{b}{a} + 2 \right]$$

$$= \frac{4}{3} = \frac{m}{n} \quad m + n = 7$$

Question38



Let a tangent to the curve $y^2 = 24x$ meet the curve $xy = 2$ at the points A and B. Then the mid points of such line segments AB lie on a parabola with the

[24-Jan-2023 Shift 1]

Options:

- A. directrix $4x = 3$
- B. directrix $4x = -3$
- C. Length of latus rectum -
- D. Length of latus rectum 2

Answer: A

Solution:

Solution:

$y^2 = 24x$
 $a = 6$
 $xy = 2$
 $AB \equiv ty = x + 6t^2 \dots (1)$
 $AB \equiv T = S_1$
 $kx + hy = 2hk \dots (2)$
 From (1) and (2)

 \Rightarrow then locus is $y^2 = -3x$
 Therefore directrix is $4x = 3$

Question39

For some $a, b, c \in \mathbb{N}$, let $f(x) = ax - 3$ and $g(x) = x^b + c, x \in \mathbb{R}$. If $(f \circ g)^{-1}(x) = \left(\frac{x-7}{2}\right)^{1/3}$ then $(f \circ g)(ac) + (g \circ f)(b)$ is equal to

_____.

[25-Jan-2023 Shift 1]

Answer: 2039

Solution:

Solution:

Let $f \circ g(x) = h(x)$

$$\Rightarrow h^{-1}(x) = \left(\frac{x-7}{2} \right)^{\frac{1}{3}}$$

$$\Rightarrow h(x) = f \circ g(x) = 2x^3 + 7$$

$$f \circ g(x) = a(x^b + c) - 3$$

$$\Rightarrow a = 2, b = 3, c = 5$$

$$\Rightarrow f \circ g(10) = 2007$$

$$g(f(x)) = (2x - 3)^3 + 5.$$

$$\Rightarrow g \circ f(3) = 32$$

$$\Rightarrow \text{sum} = 2039$$

Question40

**The area enclosed by the curves $y^2 + 4x = 4$ and $y - 2x = 2$ is :
[24-Jan-2023 Shift 1]**

Options:

A. $\frac{25}{3}$

B. $\frac{22}{3}$

C. 9

D. $\frac{23}{3}$

Answer: C

Solution:

Solution:

$$y^2 + 4x = 4$$

$$y^2 = -4(x - 1)$$

$$A = \int_{-4}^2 \left(\frac{4-y^2}{4} - \frac{y-2}{2} \right) dy = 9$$

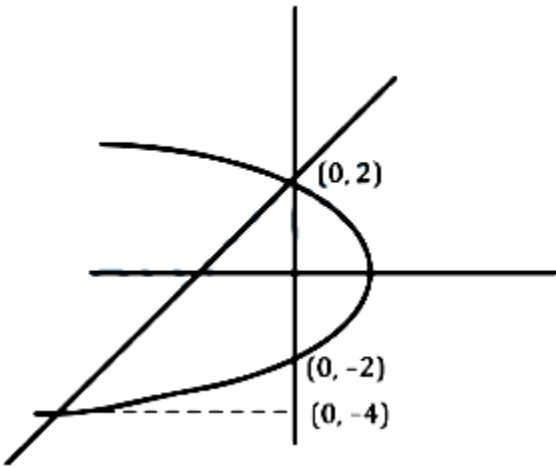

Question41

If the area of the region bounded by the curves $y^2 - 2y = -x$, $x + y = 0$ is A , then $8A$ is equal to
[24-Jan-2023 Shift 2]

Answer: 36

Solution:

$$y^2 - 2y = -x$$

$$\Rightarrow y^2 - 2y + 1 = -x + 1$$

$$(y - 1)^2 = -(x - 1)$$

$$y = -x$$

Points of intersection

$$x^2 + 2x = -x$$

$$x^2 + 3x = 0$$

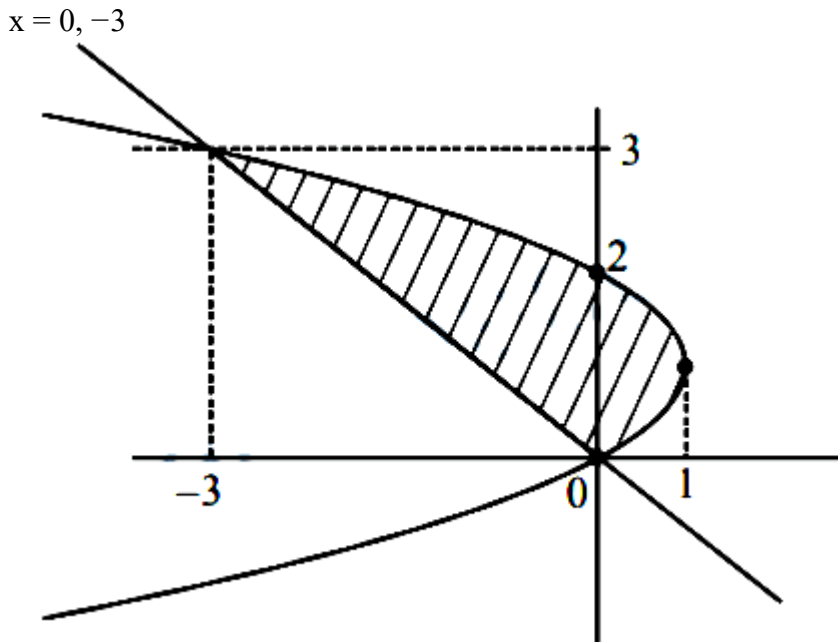

$$A = \int_0^3 (-y^2 + 2y + y) dy$$

$$= \left. \frac{3y^2}{2} - \frac{y^3}{3} \right|_0^3 = \frac{9}{2}$$

$$8A = 36$$

Question42

It the area enclosed by the parabolas $P_1 : 2y = 5x^2$ and $P_2 : x^2 - y + 6 = 0$ is equal to the area enclosed by P_1 and $y = \alpha x$, $\alpha > 0$, then α^3 is equal to _____.

[25-Jan-2023 Shift 1]

Answer: 600

Solution:

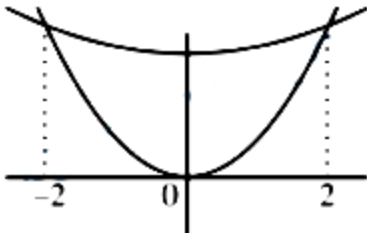

Abscissa of point of intersection of $2y = 5x^2$ and $y = x^2 + 6$ is ± 2

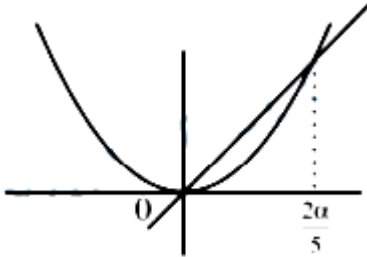

$$\begin{aligned} \text{Area} &= 2 \int_0^{\frac{2\alpha}{5}} \left(x^2 + 6 - \frac{5x^2}{2} \right) dx = \frac{2\alpha}{5} \int_0^{\frac{2\alpha}{5}} \left(\alpha x - \frac{5x^2}{2} \right) dx \\ &\Rightarrow \int_0^{\frac{2\alpha}{5}} \left(\alpha x - \frac{5x^2}{2} \right) dx = 16 \\ &\Rightarrow \alpha^3 = 600 \end{aligned}$$

Question43

Let Δ be the area of the region

$\{(x, y) \in \mathbb{R}^2 : x^2 + y^2 \leq 21, y^2 \leq 4x, x \geq 1\}$. Then $\frac{1}{2} \left(\Delta - 21 \sin^{-1} \frac{2}{\sqrt{7}} \right)$ is

equal to

[29-Jan-2023 Shift 1]

Options:

A. $2\sqrt{3} - \frac{1}{3}$

B. $\sqrt{3} - \frac{2}{3}$

C. $2\sqrt{3} - \frac{2}{3}$

D. $\sqrt{3} - \frac{4}{3}$

Answer: C

Solution:

$$\begin{aligned} \text{Area} &= 2 \int_1^3 2\sqrt{x} \, dx + 2 \int_3^{\sqrt{21}} \sqrt{21-x^2} \, dx \\ \Delta &= \frac{8}{3}(3\sqrt{3}-1) + 21 \sin^{-1}\left(\frac{2}{\sqrt{7}}\right) - 6\sqrt{3} \\ \frac{1}{2} \left(\Delta - 21 \sin^{-1}\left(\frac{2}{\sqrt{7}}\right) \right) &= \frac{2\sqrt{3}-\frac{8}{3}}{2} \\ &= \sqrt{3} - \frac{4}{3} \end{aligned}$$

Question44

Let $A = \{(x, y) \in \mathbb{R}^2 : y \geq 0, 2x \leq y \leq \sqrt{4-(x-1)^2}\}$ and

$B = \{(x, y) \in \mathbb{R} \times \mathbb{R} : 0 \leq y \leq \min\{2x, \sqrt{4-(x-1)^2}\}\}$ Then the ratio of the area of A to the area of B is

[29-Jan-2023 Shift 1]

Options:

A. $\frac{\pi-1}{\pi+1}$

B. $\frac{\pi}{\pi-1}$

C. $\frac{\pi}{\pi+1}$

D. $\frac{\pi+1}{\pi-1}$

Answer: A

Solution:

$$y^2 + (x - 1)^2 = 4$$

shaded portion = circular (OABC)

$$- \text{Ar}(\triangle OAB)$$

$$= \frac{\pi(4)}{4} - \frac{1}{2}(2)(1)$$

$$A = (\pi - 1)$$

Area B = Ar($\triangle AOB$) + Area of arc of circle (ABC)

$$= \frac{1}{2}(1)(2) + \frac{\pi(2)^2}{4} = \pi + 1$$

$$\frac{A}{B} = \frac{\pi - 1}{\pi + 1}$$

Question45

The area of the region $A = \left\{ (x, y) : |\cos x - \sin x| \leq y \leq \sin x, 0 \leq x \leq \frac{\pi}{2} \right\}$

[29-Jan-2023 Shift 2]

Options:

A. $1 - \frac{3}{\sqrt{2}} + \frac{4}{\sqrt{5}}$

B. $\sqrt{5} + 2\sqrt{2} - 4.5$

C. $\frac{3}{\sqrt{5}} - \frac{3}{\sqrt{2}} + 1$

D. $\sqrt{5} - 2\sqrt{2} + 1$

Answer: D

Solution:

Solution:

$$|\cos x - \sin x| \leq y \leq \sin x$$

Intersection point of $\cos x - \sin x = \sin x$

$$\Rightarrow \tan x = \frac{1}{2}$$

$$\text{Let } \psi = \tan^{-1} \frac{1}{2}$$

$$\text{So, } \tan \psi = \frac{1}{2}, \sin \psi = \frac{1}{\sqrt{5}}, \cos \psi = \frac{2}{\sqrt{5}}$$

$$\begin{aligned}
\text{Area} &= \int_{\psi}^{\pi/2} (\sin x - |\cos x - \sin x|) dx \\
&= \int_{\psi}^{\pi/4} (\sin x - (\cos x - \sin x)) dx \\
&\quad + \int_{\pi/4}^{\pi/2} (\sin x - (\sin x - \cos x)) dx \\
&= \int_{\psi}^{\pi/4} (2\sin x - \cos x) dx + \int_{\pi/4}^{\pi/2} \cos x dx \\
&= [-2 \cos x - \sin x]_{\psi}^{\pi/4} + [\sin x]_{\pi/4}^{\pi/2} \\
&= -\sqrt{2} - \frac{1}{\sqrt{2}} + 2 \cos \psi + \sin \psi + \left(1 - \frac{1}{\sqrt{2}}\right) \\
&= -\sqrt{2} - \frac{1}{\sqrt{2}} + 2 \left(\frac{2}{\sqrt{5}}\right) + \left(\frac{1}{\sqrt{5}}\right) + 1 - \frac{1}{\sqrt{2}} \\
&= \sqrt{5} - 2\sqrt{2} + 1
\end{aligned}$$

Question 46

Let α be the area of the larger region bounded by the curve $y^2 = 8x$ and the lines $y = x$ and $x = 2$, which lies in the first quadrant. Then the value of 3α is equal to _____.

[30-Jan-2023 Shift 1]

Answer: 22

Solution:

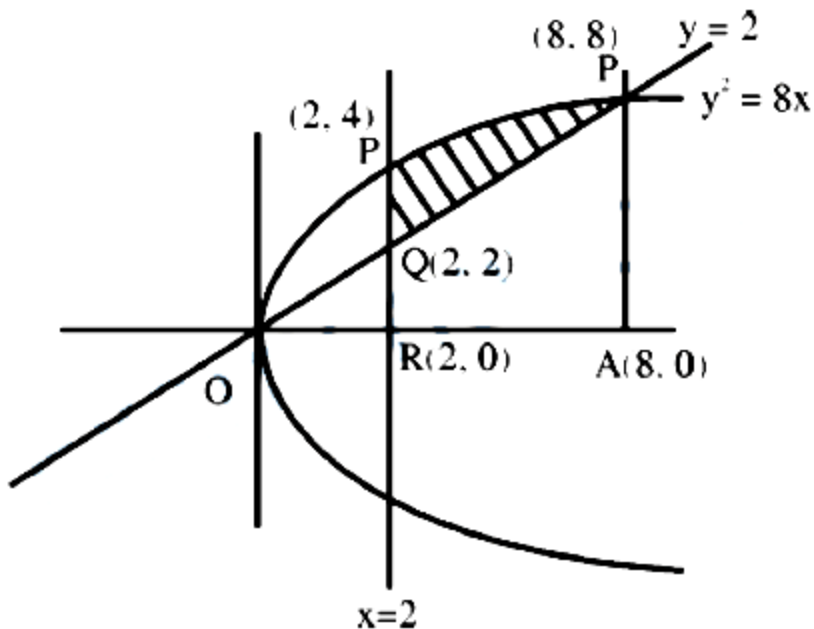

$$y = x$$

$$y^2 = 8x$$

Solving it

$$x^2 = 8x$$

$$\therefore x = 0, 8$$

$$\therefore y = 0, 8$$

$x = 2$ will intersect occur at

$$y^2 = 16 \Rightarrow y = \pm 4$$

\therefore Area of shaded

$$= \int_2^8 (\sqrt{8x} - x) dx = \int_2^8 (2\sqrt{2}\sqrt{x} - x) dx$$

$$= \left[2\sqrt{2} \cdot \frac{x^{3/2}}{3/2} - \frac{x^2}{2} \right]_2^8$$

$$= \left(\frac{4\sqrt{2}}{3} \cdot 2^{9/2} - 32 \right) - \left(\frac{4\sqrt{2}}{3} \cdot 2^{9/2} - 2 \right)$$

$$= \frac{128}{3} - 32 - \frac{16}{3} + 2 = \frac{112 - 90}{3} = \frac{22}{3} = A$$

$$\therefore 3A = 22$$

Question47

Let q be the maximum integral value of p in $[0, 10]$ for which the roots of the equation $x^2 - px + \frac{5}{4}p = 0$ are rational. Then the area of the

region $\{(x, y) : 0 \leq y \leq (x - q)^2, 0 \leq x \leq q\}$ is

[30-Jan-2023 Shift 2]



Options:

A. 243

B. 25

C. $\frac{125}{3}$

D. 164

Answer: A

Solution:

Solution:

$$x^2 - px + \frac{5p}{4} = 0$$

$$D = p^2 - 5p = p(p - 5)$$

$$\therefore q = 9$$

$$0 \leq y \leq (x - 9)^2$$

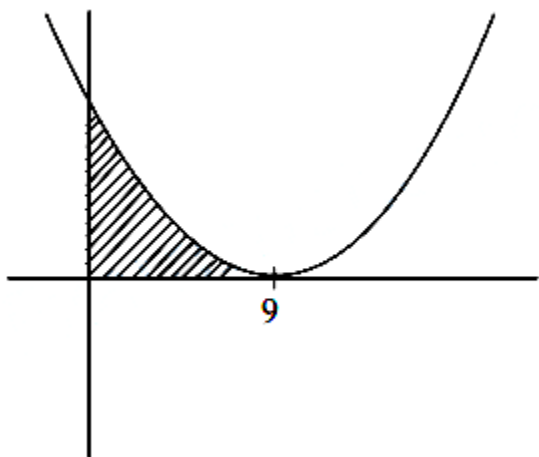

$$\text{Area} = \int_0^9 (x - 9)^2 dx = 243$$

Question48

Let A be the area of the region

$$\{(x, y) : y \geq x^2, y \geq (1 - x)^2, y \leq 2x(1 - x)\} .$$

Then 540A is equal to

[30-Jan-2023 Shift 2]

Answer: 25

Solution:

Solution:

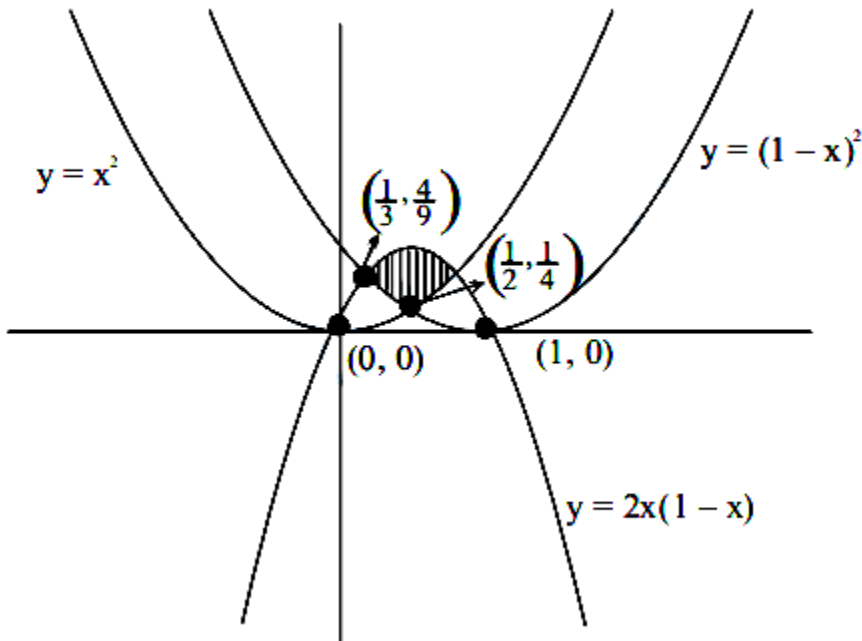

$$A = 2 \int_{\frac{1}{3}}^{\frac{2}{3}} (2x - 2x^2 - (1-x)^2) dx$$
$$= 2[2x^2 - x^3 - x]_{1/3}^{2/3}$$
$$\therefore A = \frac{5}{108} \Rightarrow 540A = \frac{5}{108} \times 540 = 25$$

Question49

Let for $x \in \mathbb{R}$

$$f(x) = \frac{x+|x|}{2} \text{ and } g(x) = \begin{cases} x, & x < 0 \\ x^2, & x \geq 0 \end{cases}$$

Then area bounded by the curve $y = (f \circ g)(x)$ and the lines

$y = 0$, $2y - x = 15$ is equal to _____.
[31-Jan-2023 Shift 1]

Answer: 72

Solution:

$$f(x) = \frac{x + |x|}{2} = \begin{cases} x & x \geq 0 \\ 0 & x < 0 \end{cases}.$$

$$g(x) = \begin{cases} x^2 & x \geq 0 \\ x & x < 0 \end{cases}.$$

$$f \circ g(x) = f[g(x)] = \begin{cases} g(x) & g(x) \geq 0 \\ 0 & g(x) < 0 \end{cases}.$$

$$f \circ g(x) = \begin{cases} x^2 & x \geq 0 \\ 0 & x < 0 \end{cases}.$$

$$2y - x = 15$$

$$\int_0^3 \left(\frac{x+15}{2} - x^2 \right) dx + \frac{1}{2} \times \frac{15}{2} \times 15$$

$$\left. \frac{x^2}{4} + \frac{15x}{2} - \frac{x^3}{3} \right|_0^3 + \frac{225}{4}$$

$$= \frac{9}{4} + \frac{45}{2} - 9 + \frac{225}{4} = \frac{99 - 36 + 225}{4}$$

$$= \frac{288}{4} = 72$$

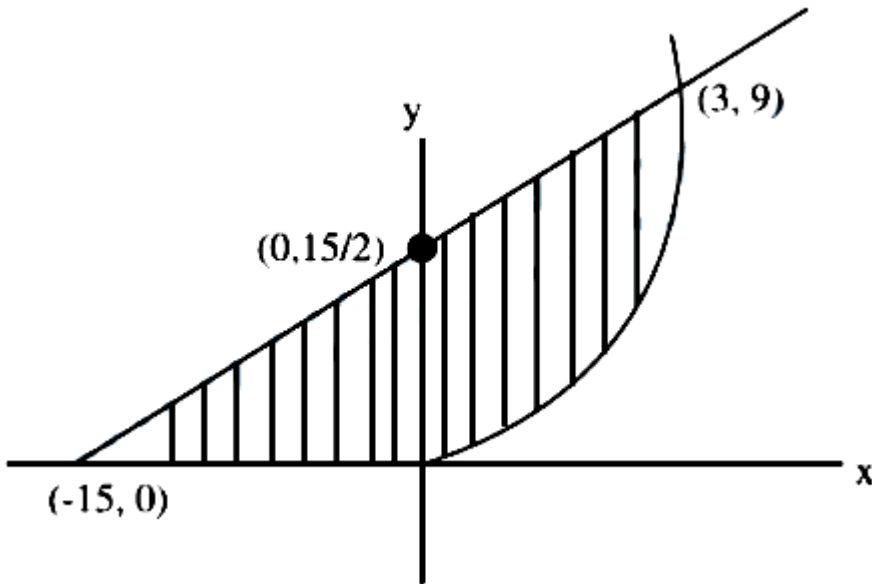

Question50

Let T and C respectively be the transverse and conjugate axes of the hyperbola $16x^2 - y^2 + 64x + 4y + 44 = 0$. Then the area of the region above the parabola $x^2 = y + 4$, below the transverse axis T and on the right of the conjugate axis C is:

[25-Jan-2023 Shift 2]

Options:

- A. $4\sqrt{6} + \frac{44}{3}$
- B. $4\sqrt{6} + \frac{28}{3}$
- C. $4\sqrt{6} - \frac{44}{3}$
- D. $4\sqrt{6} - \frac{28}{3}$

Answer: B

Solution:

$$16(x^2 + 4x) - (y^2 - 4y) + 44 = 0$$

$$16(x+2)^2 - 64 - (y-2)^2 + 4 + 44 = 0$$

$$16(x+2)^2 - (y-2)^2 = 16$$

$$\frac{(x+2)^2}{1} - \frac{(y-2)^2}{16} = 1$$

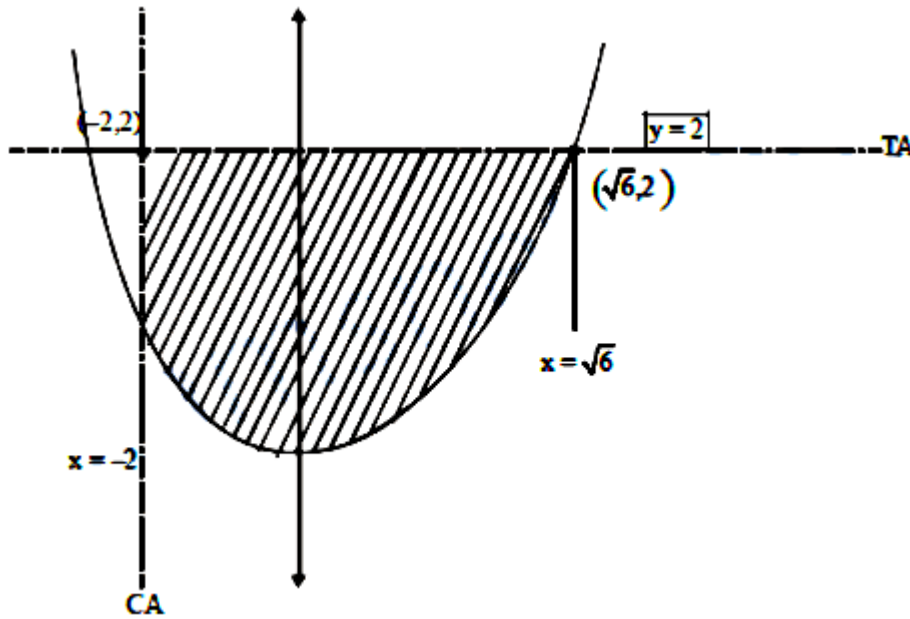

$$A = \int_{-2}^{\sqrt{6}} (2 - (x^2 - 4)) dx$$

$$A = \int_{-2}^{\sqrt{6}} (6 - x^2) dx = \left(6x - \frac{x^3}{3} \right)_{-2}^{\sqrt{6}}$$

$$A = \left(6\sqrt{6} - \frac{6\sqrt{6}}{3} \right) - \left(-12 + \frac{8}{3} \right)$$

$$A = \frac{12\sqrt{6}}{3} + \frac{28}{3}$$

$$A = 4\sqrt{6} + \frac{28}{3}$$

Question51

Let H be the hyperbola, whose foci are $(1 \pm \sqrt{2}, 0)$ and eccentricity is $\sqrt{2}$. Then the length of its lat us rectum is
[31-Jan-2023 Shift 2]

Options:

A. 2

B. 3

C. $\frac{5}{2}$

D. $\frac{3}{2}$

Answer: A

Solution:

Solution:

$$2ae = |(1 + \sqrt{2}) - (1 - \sqrt{2})| = 2\sqrt{2}$$

$$ae = \sqrt{2}$$

$$a = 1$$

$$\Rightarrow b = 1 \quad \because e = \sqrt{2} \Rightarrow \text{Hyperbola is rectangular}$$

$$\Rightarrow L \cdot R = \frac{2b^2}{a} = 2$$

Question52

The locus of the mid points of the chords of the circle

$C_1 : (x - 4)^2 + (y - 5)^2 = 4$ which subtend an angle θ_i at the centre of the circle C_1 , is a circle of radius r_i . If $\theta_1 = \frac{\pi}{3}$, $\theta_3 = \frac{2\pi}{3}$ and $r_1^2 = r_2^2 + r_3^2$, then θ_2 is equal to

[24-Jan-2023 Shift 2]

Options:

A. $\frac{\pi}{4}$

B. $\frac{3\pi}{4}$

C. $\frac{\pi}{6}$

D. $\frac{\pi}{2}$

Answer: D

Solution:

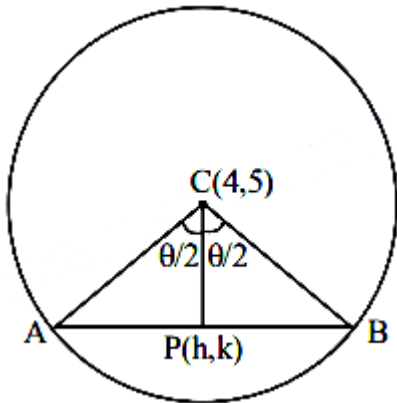

$$\cos \frac{\theta}{2} = \frac{PC}{2} \Rightarrow PC = 2 \cos \frac{\theta}{2}$$

$$\Rightarrow (h-4)^2 + (k-5)^2 = 4 \cos^2 \frac{\theta}{2}$$

$$\text{Now } (x-4)^2 + (y-5)^2 = \left(2 \cos \frac{\theta}{2}\right)^2$$

$$\Rightarrow r_1 = 2 \cos \frac{\pi}{6} = \sqrt{3}$$

$$r_2 = 2 \cos \frac{\theta_2}{2}$$

$$r_3 = 2 \cos \frac{\pi}{3} = 1$$

$$\Rightarrow r_1^2 = r_2^2 + r_3^2$$

$$\Rightarrow 3 = 4 \cos^2 \frac{\theta_2}{2} + 1$$

$$\Rightarrow 4 \cos^2 \frac{\theta_2}{2} = 2$$

$$\Rightarrow \cos \frac{\theta_2}{2} = \frac{1}{2}$$

$$\Rightarrow \theta_2 = \frac{\pi}{2}$$

Question 53

The locus of the mid points of the chords of the circle

$C_1 : (x-4)^2 + (y-5)^2 = 4$ which subtend an angle θ_i at the centre of the circle C_1 , is a circle of radius r_i . If $\theta_1 = \frac{\pi}{3}$, $\theta_3 = \frac{2\pi}{3}$ and $r_1^2 = r_2^2 + r_3^2$,

then θ_2 is equal to
[24-Jan-2023 Shift 2]

Options:

- A. $\frac{\pi}{4}$
- B. $\frac{3\pi}{4}$
- C. $\frac{\pi}{6}$
- D. $\frac{\pi}{2}$

Answer: D

Solution:

Solution:

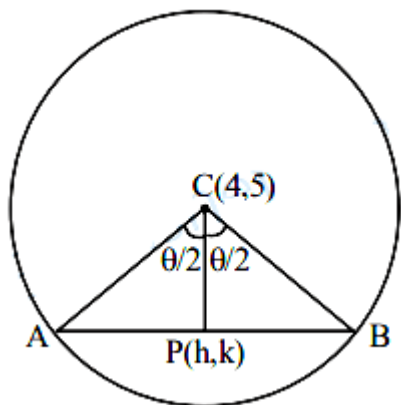

$$\cos \frac{\theta}{2} = \frac{PC}{2} \Rightarrow PC = 2 \cos \frac{\theta}{2}$$

$$\Rightarrow (h-4)^2 + (k-5)^2 = 4 \cos^2 \frac{\theta}{2}$$

$$\text{Now } (x-4)^2 + (y-5)^2 = \left(2 \cos \frac{\theta}{2}\right)^2$$

$$\Rightarrow r_1 = 2 \cos \frac{\pi}{6} = \sqrt{3}$$

$$r_2 = 2 \cos \frac{\theta_2}{2}$$

$$r_3 = 2 \cos \frac{\pi}{3} = 1$$

$$\Rightarrow r_1^2 = r_2^2 + r_3^2$$

$$\Rightarrow 3 = 4 \cos^2 \frac{\theta_2}{2} + 1$$

$$\Rightarrow 4\cos^2 \frac{\theta_2}{2} = 2$$

$$\Rightarrow \cos \frac{\theta_2}{2} = \frac{1}{2}$$

$$\Rightarrow \theta_2 = \frac{\pi}{2}$$

Question54

The points of intersection of the line $ax + by = 0$, ($a \neq b$) and the circle $x^2 + y^2 - 2x = 0$ are $A(\alpha, 0)$ and $B(1, \beta)$. The image of the circle with AB as a diameter in the line $x + y + 2 = 0$ is :

[25-Jan-2023 Shift 1]

Options:

A. $x^2 + y^2 + 5x + 5y + 12 = 0$

B. $x^2 + y^2 + 3x + 5y + 8 = 0$

C. $x^2 + y^2 + 3x + 3y + 4 = 0$

D. $x^2 + y^2 - 5x - 5y + 12 = 0$

Answer: A

Solution:

Solution:

Only possibility $\alpha = 0, \beta = 1$

\therefore equation of circle $x^2 + y^2 - x - y = 0$

Image of circle in $x + y + 2 = 0$ is

$$x^2 + y^2 + 5x + 5y + 12 = 0$$

Question55

Points $P(-3, 2)$, $Q(9, 10)$ and $R(\alpha, 4)$ lie on a circle C with PR as its diameter. The tangents to C at the points Q and R intersect at the

point S. If S lies on the line $2x - ky = 1$, then k is equal to _____.
 [25-Jan-2023 Shift 2]

Answer: 3

Solution:

Solution:

$$m_{PQ} \cdot m_{QR} = -1$$

$$\Rightarrow \frac{10-2}{9+3} \times \frac{10-4}{9-\alpha} = -1 \Rightarrow \alpha = 13$$

$$m_{OP} \cdot m_{QS} = -1 \Rightarrow m_{QS} = -\frac{4}{7}$$

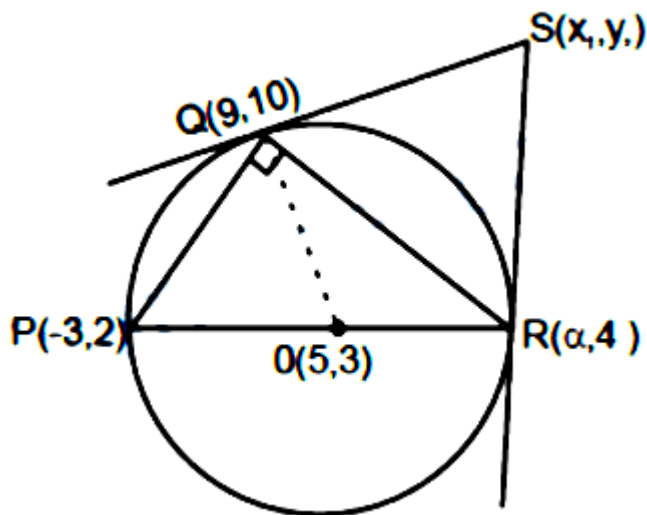

Equation of QS

$$y - 10 = -\frac{4}{7}(x - 9)$$

$$\Rightarrow 4x + 7y = 106 \dots (1)$$

$$m_{OR} \cdot m_{RS} = -1 \Rightarrow m_{RS} = -8$$

Equation of RS

$$y - 4 = -8(x - 13)$$

$$\Rightarrow 8x + y = 108$$

Solving eq. (1) & (2)

$$x_1 = \frac{25}{2}y_1 = 8$$

$S(x_1, y_1)$ lies on $2x - ky = 1$

$$25 - 8k = 1$$

$$\Rightarrow 8k = 24$$

$$\Rightarrow k = 3$$

Question56

Let the tangents at the points $A(4, -11)$ and $B(8, -5)$ on the circle $x^2 + y^2 - 3x + 10y - 15 = 0$, intersect at the point C . Then the radius of the circle, whose centre is C and the line joining A and B is its tangent, is equal to
[29-Jan-2023 Shift 1]

Options:

A. $\frac{3\sqrt{3}}{4}$

B. $2\sqrt{13}$

C. $\sqrt{13}$

D. $\frac{2\sqrt{13}}{3}$

Answer: D

Solution:

Solution:

Equation of tangent at $A(4, -11)$ on circle is

$$\Rightarrow 4x - 11y - 3\left(\frac{x+4}{2}\right) + 10\left(\frac{y-11}{2}\right) - 15 = 0$$

$$\Rightarrow 5x - 12y - 152 = 0 \dots\dots (1)$$

Equation of tangent at $B(8, -5)$ on circle is

$$\Rightarrow 8x - 5y - 3\left(\frac{x+8}{2}\right) + 10\left(\frac{y-5}{2}\right) - 15 = 0$$

$$\Rightarrow 13x - 104 = 0 \Rightarrow x = 8$$

put in (1) $\Rightarrow y = \frac{28}{3}$

$$r = \left| \frac{3 \cdot 8 + \frac{2 \cdot 28}{3} - 34}{\sqrt{13}} \right| = \frac{2\sqrt{13}}{3}$$

Question57

A circle with centre $(2, 3)$ and radius 4 intersects the line $x + y = 3$ at the points P and Q. If the tangents at P and Q intersect at the point $S(\alpha, \beta)$, then $4\alpha - 7\beta$ is equal to _____.
[29-Jan-2023 Shift 2]

Answer: 11

Solution:

Solution:

The given line is polar or $P(2, \beta)$ w.r.t. given circle

$$x^2 + y^2 - 4x - 6y - 3 = 0$$

Chord or contact

$$\alpha x + \beta y - 2(x + \alpha) - 3(y + \beta) - 3 = 0$$

$$\Rightarrow (\alpha - 2)x + (\beta - 3)y - (2\alpha + 3\beta + 3) = 0 \dots (i)$$

\therefore But the equation of chord of contact is given

$$\text{as : } x + y - 3 = 0 \dots (ii)$$

comparing the coefficients

$$\frac{\alpha - 2}{1} = \frac{\beta - 3}{1} = -\left(\frac{2\alpha + 3\beta + 3}{-3}\right)$$

On solving $\alpha = -6$

$$\beta = -5$$

$$\text{Now } 4\alpha - 7\beta = 11$$

Question58

Let $y = x + 2$, $4y = 3x + 6$ and $3y = 4x + 1$ be three tangent lines to the circle $(x - h)^2 + (y - k)^2 = r^2$. Then $h + k$ is equal to :
[30-Jan-2023 Shift 1]

Options:

A. 5

B. $5(1 + \sqrt{2})$

C. 6

D. $5\sqrt{2}$

Answer: A

Solution:

Solution:

$$L_1 : y = x + 2, L_2 : 4y = 3x + 6, L_3 : 3y = 4x + 1$$

Bisector of lines L_2 & L_3

$$\frac{4x - 3y + 1}{5} = \pm \left(\frac{3x - 4y + 6}{5} \right)$$

$$(+)\ 4x - 3y + 1 = 3x - 4y + 6$$

$$x + y = 5$$

Centre lies on Bisector of $4x - 3y + 1 = 0$ &

$$(0)\ 3x - 4y + 6 = 0$$

$$\Rightarrow h + k = 5$$

Question 59

Let $P(a_1, b_1)$ and $Q(a_2, b_2)$ be two distinct points on a circle with center $C(\sqrt{2}, \sqrt{3})$. Let O be the origin and OC be perpendicular to both CP and CQ . If the area of the triangle OCP is $\frac{\sqrt{35}}{2}$, then $a_1^2 + a_2^2 + b_1^2 + b_2^2$

is equal to _____.

[30-Jan-2023 Shift 2]

Answer: 24

Solution:

Solution:

$$\frac{1}{2} \times PC \times \sqrt{5} = \frac{\sqrt{35}}{2}; PC = \sqrt{7}$$

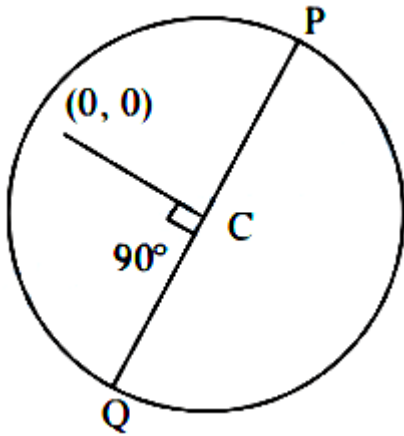

$$a_1^2 + b_1^2 + a_2^2 + b_2^2 = OP^2 + OQ^2$$

$$= 2(5 + 7) = 24$$

Question60

Let a circle C_1 be obtained on rolling the circle $x^2 + y^2 - 4x - 6y + 11 = 0$ upwards 4 units on the tangent T to it at the point $(3, 2)$. Let C_2 be the image of C_1 in T . Let A and B be the centers of circles C_1 and C_2 respectively, and M and N be respectively the feet of perpendiculars drawn from A and B on the x -axis. Then the area of the trapezium $AMNB$ is :

[31-Jan-2023 Shift 1]

Options:

- A. $2(2 + \sqrt{2})$
- B. $4(1 + \sqrt{2})$
- C. $3 + 2\sqrt{2}$
- D. $2(1 + \sqrt{2})$

Answer: B

Solution:

$$C = (2, 3), r = \sqrt{2}$$

$$\text{Centre of } G = A = 2 + 4 \frac{1}{\sqrt{2}},$$

$$3 + \frac{4}{\sqrt{2}} = (2 + 2\sqrt{2}, 3 + 2\sqrt{2})$$

$$A(2 + 2\sqrt{2}, 3 + 2\sqrt{2})$$

$$B(4 + 2\sqrt{2}, 1 + 2\sqrt{2})$$

$$\frac{x - (2 + 2\sqrt{2})}{1} = \frac{y - (3 + 2\sqrt{2})}{-1} = 2$$

\therefore area of trapezium:

$$\frac{1}{2}(4 + 4\sqrt{2})2 = 4(1 + \sqrt{2})$$

Question 61

The set of all values of a^2 for which the line $x + y = 0$ bisects two distinct chords drawn from a point $P\left(\frac{1+a}{2}, \frac{1-a}{2}\right)$ on the circle

$2x^2 + 2y^2 - (1+a)x - (1-a)y = 0$ is equal to:

[31-Jan-2023 Shift 2]

Options:

A. $(8, \infty)$

B. $(4, \infty)$

C. $(0, 4]$

D. $(2, 12]$

Answer: A

Solution:

Solution:

$$x^2 + y^2 - \frac{(1+a)x}{2} - \frac{(1-a)y}{2} = 0$$

$$\text{Centre } \left(\frac{1+a}{4}, \frac{1-a}{4}\right) \Rightarrow (h, k)$$

$$P\left(\frac{1+a}{2}, \frac{1-a}{2}\right) \Rightarrow (2h, 2k)$$

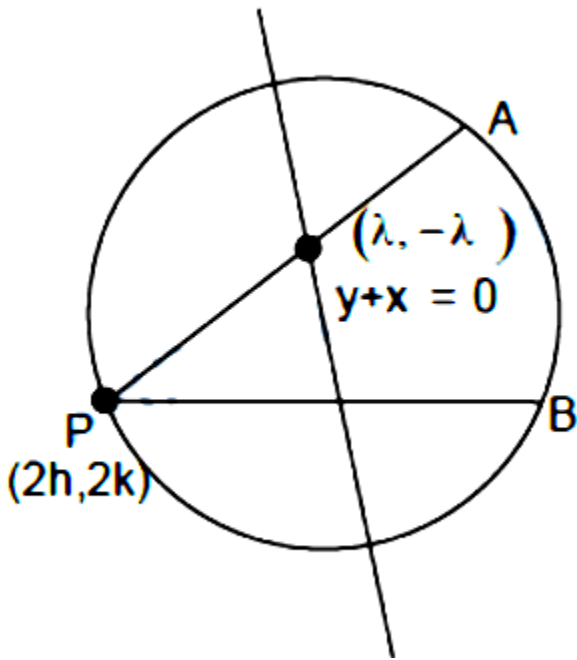

Equation of chord $\Rightarrow T = S_1$

$$\Rightarrow (x-y)\lambda - \frac{2h(x+\lambda)}{2} - \frac{(2k)(y-\lambda)}{2}$$

$$= 2\lambda^2 - 2h(\lambda) + 2k\lambda$$

Now, $\lambda(2h, 2k)$ satisfies the chord

$$\therefore (2h-2k)\lambda - h(x+\lambda) - k(y-\lambda)$$

$$\Rightarrow 2\lambda^2 + 4k\lambda - 4h\lambda + h\lambda - k\lambda + hx + ky = 0$$

$$\Rightarrow 2\lambda^2 + \lambda(3k-3h) + ky + hx = 0$$

$$\Rightarrow D > 0$$

$$\Rightarrow 9(k-h)^2 - 8(ky+hx) > 0$$

$$\Rightarrow 9(k-h)^2 - 8(2k^2+2h^2) > 0$$

$$\Rightarrow -7k^2 - 7h^2 - 18kh > 0$$

$$\Rightarrow 7k^2 + 7h^2 + 18kh < 0$$

$$\Rightarrow 7\left(\frac{1-a}{4}\right)^2 + 7\left(\frac{1+a}{4}\right)^2 + 18\left(\frac{1-a^2}{16}\right) < 0$$

$$\Rightarrow 7\left[\frac{2(1+a^2)}{16}\right] + \frac{18(1-a^2)}{16} < 0, \quad a^2 = t$$

$$\Rightarrow \frac{7}{8}(1+t) + \frac{18(1-t)}{16} < 0$$

$$\Rightarrow \frac{14+14t+18-18t}{16} < 0$$

$$\Rightarrow 4t > 32$$

$$t > 8 \quad a^2 > 8$$

Question62

The equations of the sides AB and AC of a triangle ABC are $(\lambda + 1)x + \lambda y = 4$ and $\lambda x + (1 - \lambda)y + \lambda = 0$ respectively. Its vertex A is on

the y-axis and its orthocentre is (1, 2). The length of the tangent from the point C to the part of the parabola $y^2 = 6x$ in the first quadrant is [24-Jan-2023 Shift 2]

Options:

A. $\sqrt{6}$

B. $2\sqrt{2}$

C. 2

D. 4

Answer: B

Solution:

Solution:

$$AB : (\lambda + 1)x + \lambda y = 4$$

$$AC : \lambda x + (1 - \lambda)y + \lambda = 0$$

Vertex A is on y-axis

$$\Rightarrow x = 0$$

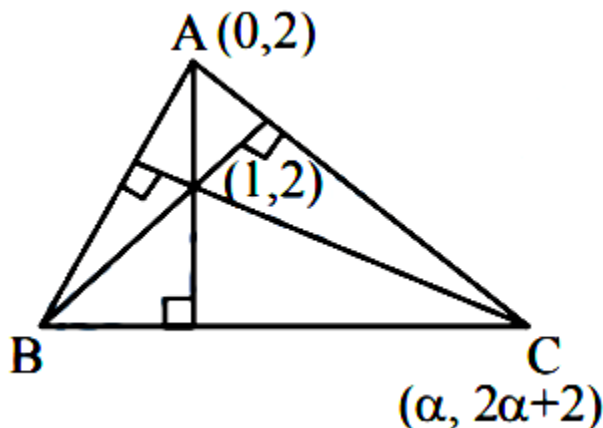

$$\text{So } y = \frac{4}{\lambda}, y = \frac{\lambda}{\lambda - 1}$$

$$\Rightarrow \frac{4}{\lambda} = \frac{\lambda}{\lambda - 1}$$

$$\Rightarrow \lambda = 2$$

$$AB : 3x + 2y = 4$$

$$AC : 2x - y + 2 = 0$$

$$\Rightarrow A(0, 2) \text{ Let } C(\alpha, 2\alpha + 2)$$

$$\text{Now (Slope of Altitude through C)} \left(-\frac{3}{2}\right) = -1$$



$$\left(\frac{2\alpha}{\alpha-1}\right)\left(-\frac{3}{2}\right) = -1 \Rightarrow \alpha = -\frac{1}{2}$$

So $C\left(-\frac{1}{2}, 1\right)$

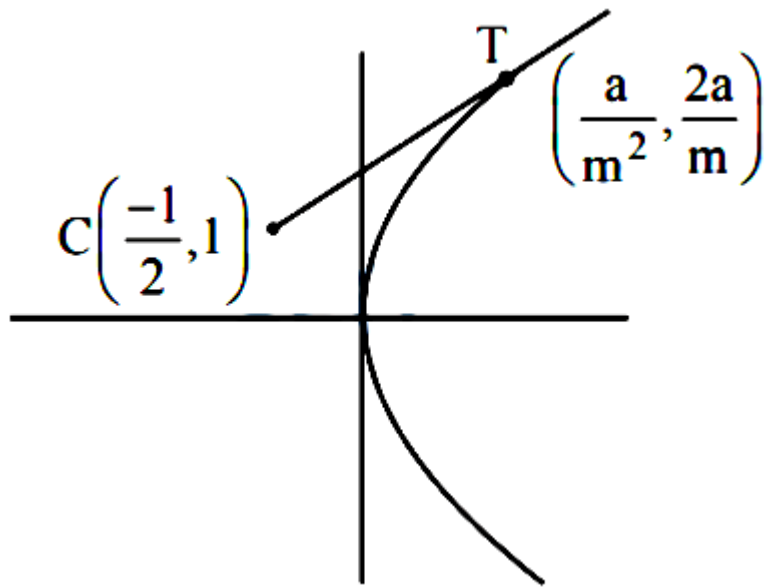

Let Equation of tangent be $y = mx + \frac{3}{2m}$

$$m^2 + 2m - 3 = 0$$

$$\Rightarrow m = 1, -3$$

So tangent which touches in first quadrant at T is

$$T \equiv \left(\frac{a}{m^2}, \frac{2a}{m}\right)$$

$$\equiv \left(\frac{3}{2}, 3\right)$$

$$\Rightarrow CT = \sqrt{4+4} = 2\sqrt{2}$$

Question63

The urns A, B and C contain 4 red, 6 black; 5 red, 5 black and λ red, 4 black balls respectively. One of the urns is selected at random and a ball is drawn. If the ball drawn is red and the probability that it is drawn from urn C is 0.4 then the square of the length of the side of the largest equilateral triangle, inscribed in the parabola $y^2 = \lambda x$ with one vertex at the vertex of the parabola is
[24-Jan-2023 Shift 2]

Answer: 432

Solution:

Solution:

$$P\left(\frac{C}{R}\right) = \frac{P(C)P\left(\frac{R}{C}\right)}{P(A)P\left(\frac{R}{A}\right) + P(B)P\left(\frac{R}{B}\right) + P(C)P\left(\frac{R}{C}\right)}$$

$$0.4 = \frac{\frac{1}{3} \times \frac{\lambda}{(\lambda+4)}}{\frac{1}{3} \times \frac{4}{10} + \frac{1}{3} \times \frac{5}{10} + \frac{1}{3} \times \frac{\lambda}{(\lambda+4)}}$$

$$\Rightarrow \lambda = 6$$

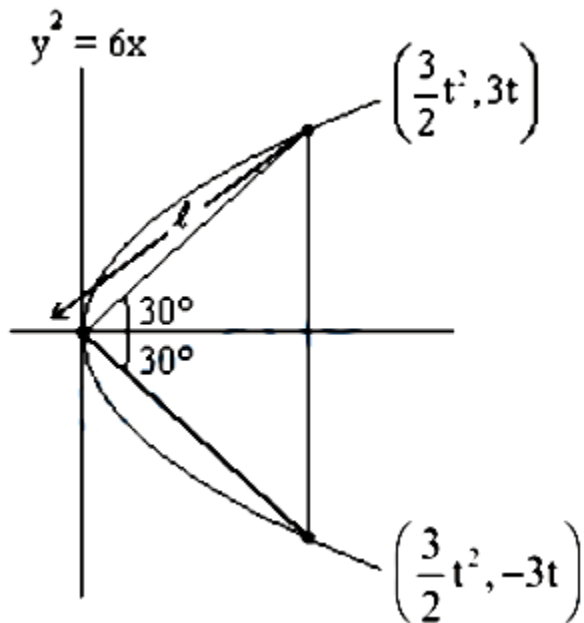

$$\tan 30^\circ = 3t = \frac{3}{2}t^2$$

$$\frac{1}{\sqrt{3}} = \frac{2}{t}$$

$$t = 2\sqrt{3}$$

$$\left(\frac{3}{2}t^2, 3t\right) = (18, 6\sqrt{3})$$

$$\ell^2 = 18^2 + (6\sqrt{3})^2$$

$$= 324 + 108$$

$$= 432$$

Question64

Let a tangent to the Curve $9x^2 + 16y^2 = 144$ intersect the coordinate axes at the points A and B. Then, the minimum length of the line segment AB is
[24-Jan-2023 Shift 1]

Answer: 7

Solution:

Solution:

Equation of tangent at point $P(4 \cos \theta, 3 \sin \theta)$ is $\frac{x \cos \theta}{4} + \frac{y \sin \theta}{3} = 1$ So A is $(4 \sec \theta, 0)$ and point B is $(0, 3 \operatorname{cosec} \theta)$

$$\begin{aligned} \text{Length AB} &= \sqrt{16 \sec^2 \theta + 9 \operatorname{cosec}^2 \theta} \\ &= \sqrt{25 + 16 \tan^2 \theta + 9 \cot^2 \theta} \geq 7 \end{aligned}$$

Question65

Let C be the largest circle centred at $(2, 0)$ and inscribed in the ellipse
 $= \frac{x^2}{36} + \frac{y^2}{16} = 1$.

If $(1, \alpha)$ lies on C, then $10\alpha^2$ is equal to _____
[24-Jan-2023 Shift 1]

Answer: 118

Solution:

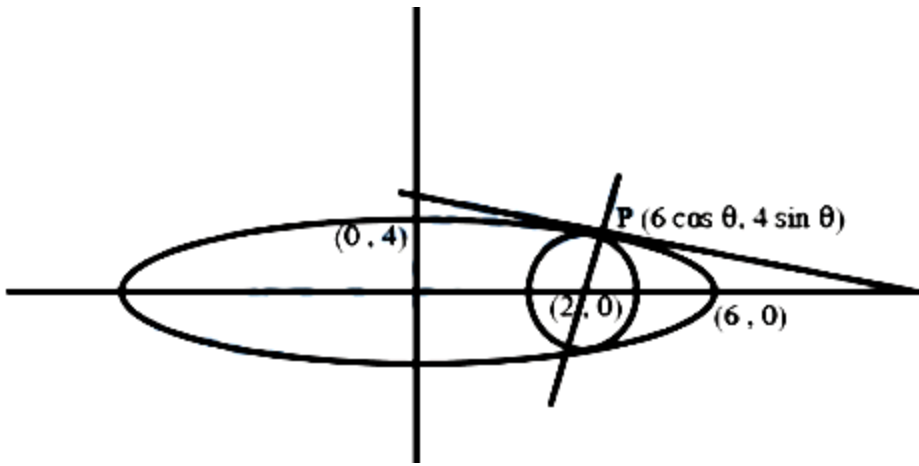

Equation of normal of ellipse $\frac{x^2}{36} + \frac{y^2}{16} = 1$ at any point $P(6 \cos \theta, 4 \sin \theta)$ is

$3 \sec \theta x - 2 \operatorname{cosec} \theta y = 10$ this normal is also the normal of the circle passing through the point $(2, 0)$ So,
 $6 \sec \theta = 10$ or $\sin \theta = 0$ (Not possible)

$$\cos \theta = \frac{3}{5} \text{ and } \sin \theta = \frac{4}{5} \text{ so point } P = \left(\frac{18}{5}, \frac{16}{5} \right)$$

So the largest radius of circle

$$\sqrt{320}$$

$$\text{So the equation of circle } (x - 2)^2 + y^2 = \frac{64}{5}$$

Passing it through $(1, \alpha)$

$$\text{Then } \alpha^2 = \frac{59}{5}$$

$$10\alpha^2 = 118$$

Question66

If the tangent at a point P on the parabola $y^2 = 3x$ is parallel to the line $x + 2y = 1$ and the tangents at the points Q and R on the ellipse

$\frac{x^2}{4} + \frac{y^2}{1} = 1$ are perpendicular to the line $x - y = 2$, then the area of the triangle PQR is:

[29-Jan-2023 Shift 2]

Options:

A. $\frac{9}{\sqrt{5}}$

B. $5\sqrt{3}$

C. $\frac{3}{2}\sqrt{5}$

D. $3\sqrt{5}$

Answer: D

Solution:

Solution:

$$y^2 = 3x$$

Tangent $P(x_1, y_1)$ is parallel to $x + 2y = 1$

Then slope at $P = -\frac{1}{2}$

$$2y \frac{dy}{dx} = 3$$

$$\Rightarrow \frac{dy}{dx} = \frac{3}{2y} = -\frac{1}{2}$$

$$\Rightarrow y_1 = -3$$

Coordinates of $P(3, -3)$

Similarly $Q\left(\frac{4}{\sqrt{3}}, \frac{1}{\sqrt{5}}\right), R\left(-\frac{4}{\sqrt{5}}, \frac{-1}{\sqrt{5}}\right)$

Area of $\triangle PQR$

$$= \frac{1}{2}[3 \ -3 \ 1]$$

$$= \frac{1}{2}\left[3\left(\frac{2}{\sqrt{5}}\right) + 3\left(\frac{8}{\sqrt{5}}\right) + 0\right] = \frac{30}{2\sqrt{5}} = 3\sqrt{5}$$

Question67

If the maximum distance of normal to the ellipse $\frac{x^2}{4} + \frac{y^2}{b^2} = 1, b < 2,$ from the origin is 1, then the eccentricity of the ellipse is:
[31-Jan-2023 Shift 1]

Options:

A. $\frac{1}{\sqrt{2}}$

B. $\frac{\sqrt{3}}{2}$

C. $\frac{1}{2}$

D. $\frac{\sqrt{3}}{4}$

Answer: B

Solution:

Solution:

Equation of normal is

$$2x \sec\theta - by \operatorname{cosec}\theta = 4 - b^2$$

$$\text{Distance from } (0, 0) = \frac{4 - b^2}{\sqrt{4 \sec^2\theta + b^2 \operatorname{cosec}^2\theta}}$$

Distance is maximum if

$4 \sec^2\theta + b^2 \operatorname{cosec}^2\theta$ is minimum

$$\Rightarrow \tan^2\theta = \frac{b}{2}$$

$$\Rightarrow \frac{4 - b^2}{\sqrt{4 \cdot \frac{b+2}{2} + b^2 \cdot \frac{b+2}{b}}} = 1$$

$$\Rightarrow 4 - b^2 = b + 2 \Rightarrow b = 1 \Rightarrow e = \frac{\sqrt{3}}{2}$$

Question68

If P(h, k) be point on the parabola $x = 4y^2$, which is nearest to the point Q(0, 33), then the distance of P from the directrix of the parabola

$y^2 = 4(x + y)$ is equal to :

[30-Jan-2023 Shift 1]

Options:

A. 2

B. 4

C. 8

D. 6

Answer: D

Solution:

Solution:

Equation of normal

$$y = -tx + 2at + at^3$$

$$y = -tx + \frac{2}{16}t + \frac{1}{16}t^3$$

It passes through (0, 33)

$$33 = \frac{t}{8} + \frac{t^3}{16}$$

$$t^3 + 2t - 528 = 0$$

$$(t - 8)(t^2 + 8t + 66) = 0$$

$$t = 8$$

$$P(at^2, 2at) = \left(\frac{1}{16} \times 64, 2 \times \frac{1}{16} \times 8 \right) = (4, 1)$$

Parabola :

$$y^2 = 4(x + y)$$

$$\Rightarrow y^2 - 4y = 4x$$

$$\Rightarrow (y - 2)^2 = 4(x + 1)$$

Equation of directrix :-

$$x + 1 = -1$$

$$x = -2$$

Distance of point = 6

Ans. : (4)

Question69

The distance of the point $(6, -2\sqrt{2})$ from the common tangent $y = mx + c$, $m > 0$, of the curves $x = 2y^2$ and $x = 1 + y^2$ is
[25-Jan-2023 Shift 1]

Options:

A. $\frac{1}{3}$

B. 5

C. $\frac{14}{3}$

D. $5\sqrt{3}$

Answer: B

Solution:

Solution:

For

$$y^2 = \frac{x}{2}, T: y = mx + \frac{1}{8m}$$

For tangent to $y^2 + 1 = x$

$$\Rightarrow \left(mx + \frac{1}{8m}\right)^2 + 1 = x$$

$$D = 0 \Rightarrow m = \frac{1}{2\sqrt{2}}$$

$$\therefore T: x - 2\sqrt{2}y + 1 = 0$$

$$d = \left| \frac{6+8+1}{\sqrt{9}} \right| = 5$$

Question70

Let A be a point on the x-axis. Common tangents are drawn from A to the curves $x^2 + y^2 = 8$ and $y^2 = 16x$. If one of these tangents touches the two curves at Q and R, then $(QR)^2$ is equal to
[30-Jan-2023 Shift 2]

Options:

A. 64

B. 76

C. 81

D. 72

Answer: D

Solution:

$$y = mx + \frac{4}{m}$$

$$\frac{\left| \frac{4}{m} \right|}{\sqrt{1+m^2}} = 2\sqrt{2} \therefore m = \pm 1$$

$$\text{Let } m = 1, \left(\frac{a}{m^2}, \frac{2a}{m} \right)$$

$$R(4, 8)$$

Point of contact on circle $Q(-2, 2)$

$$\therefore (QR)^2 = 36 + 36 = 72$$

Question71

Let S be the set of all $a \in \mathbb{N}$ such that the area of the triangle formed by the tangent at the point $P(b, c)$, $b, c \in \mathbb{N}$, on the parabola $y^2 = 2ax$ and the lines $x = b$, $y = 0$ is 16 unit^2 , then $\sum_{a \in S} a$ is equal to _____.

[31-Jan-2023 Shift 2]

Answer: 146

Solution:

Solution:

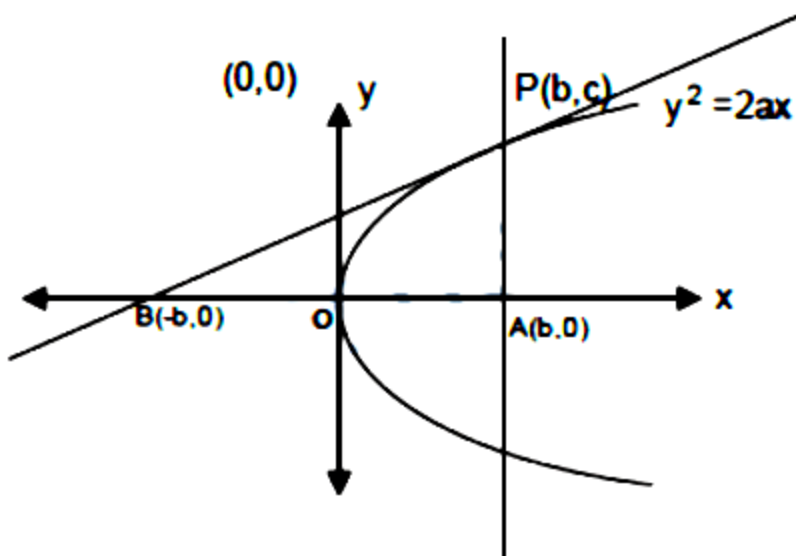

As P(b, c) lies on parabola so $c^2 = 2ab \dots (1)$

Now equation of tangent to parabola $y^2 = 2ax$ in point form is $yy_1 = 2a \frac{(x+x_1)}{2}$, $(x_1, y_1) = (b, c)$

$$\Rightarrow yc = a(x+b)$$

For point B, put $y = 0$, now $x = -b$

$$\text{So, area of } \triangle PBA, \frac{1}{2} \times AB \times AP = 16$$

$$\Rightarrow \frac{1}{2} \times 2b \times c = 16$$

$$\Rightarrow bc = 16$$

As b and c are natural number so possible values of (b, c) are (1, 16), (2, 8), (4, 4), (8, 2) and (16, 1)

Now from equation (1) $a = \frac{c^2}{2b}$ and $a \in \mathbb{N}$, so values of (b, c) are (1, 16), (2, 8) and (4, 4) now values of a are 128, 16 and 2.

Hence sum of values of a is 146.

Question 72

The area enclosed by the closed curve C given by the differential equation $\frac{dy}{dx} + \frac{x+a}{y-2} = 0$, $y(1) = 0$ is 4π .

Let P and Q be the points of intersection of the curve C and the y-axis. If normals at P and Q on the curve C intersect x-axis at points R and S respectively, then the length of the line segment RS is
[1-Feb-2023 Shift 1]

Options:

A. $2\sqrt{3}$

B. $\frac{2\sqrt{3}}{3}$

C. 2

D. $\frac{4\sqrt{3}}{3}$

Answer: D

Solution:

$$\frac{dy}{dx} + \frac{x+a}{y-2} = 0$$

$$\frac{dy}{dx} = \frac{x+a}{2-y}$$

$$(2-y) dy = (x+a) dx$$

$$2y \frac{-y}{2} = \frac{x^2}{2} + ax + c$$

$$a + c = -\frac{1}{2} \text{ as } y(1) = 0$$

$$X^2 + y^2 + 2ax - 4y - 1 - 2a = 0$$

$$\pi r^2 = 4\pi$$

$$r^2 = 4$$

$$4 = \sqrt{a^2 + 4 + 1 + 2a}$$

$$(a+1)^2 = 0$$

$$P, Q = (0, 2 \pm \sqrt{3})$$

$$\text{Equation of normal at P, Q are } y - 2 = \sqrt{3}(x - 1)$$

$$y - 2 = -\sqrt{3}(x - 1)$$

$$R = \left(1 - \frac{2}{\sqrt{3}}, 0\right)$$

$$S = \left(1 + \frac{2}{\sqrt{3}}, 0\right)$$

$$RS = \frac{4}{\sqrt{3}} = 4 \frac{\sqrt{3}}{3}$$

Question 73

Let A be the area bounded by the curve $y = x |x - 3|$, the x -axis and the ordinates $x = -1$ and $x = 2$. Then $12A$ is equal to _____.

[1-Feb-2023 Shift 1]

Answer: 62

Solution:

Solution:

$$A = \int_{-1}^0 (x^2 - 3x) dx + \int_0^2 (3x - x^2) dx$$

$$\Rightarrow A = \frac{x^3}{3} - \frac{3x^2}{2} \Big|_{-1}^0 + \frac{3x^2}{2} - \frac{x^3}{3} \Big|_0^2$$

$$\Rightarrow A = \frac{11}{6} + \frac{10}{3} = \frac{31}{6}$$

$$\therefore 12A = 62$$

Question 74

If $A = \frac{1}{2} \begin{bmatrix} 1 & \sqrt{3} \\ -\sqrt{3} & 1 \end{bmatrix}$, then :

[1-Feb-2023 Shift 2]

Options:

A. $A^{30} - A^{25} = 2I$

B. $A^{30} + A^{25} + A = I$

C. $A^{30} + A^{25} - A = I$

D. $A^{30} = A^{25}$

Answer: C

Solution:

Solution:

$$A = \frac{1}{2} \begin{bmatrix} 1 & \sqrt{3} \\ -\sqrt{3} & 1 \end{bmatrix}$$

$$A = \begin{bmatrix} \cos 60^\circ & \sin 60^\circ \\ -\sin 60^\circ & \cos 60^\circ \end{bmatrix}$$

$$\text{If } A = \begin{bmatrix} \cos \alpha & \sin \alpha \\ -\sin \alpha & \cos \alpha \end{bmatrix} \text{ Here } \alpha = \frac{\pi}{3}$$

$$= \begin{bmatrix} \cos 2\alpha & \sin 2\alpha \\ -\sin 2\alpha & \cos 2\alpha \end{bmatrix}$$

$$A^{30} = \begin{bmatrix} \cos 30\alpha & \sin 30\alpha \\ -\sin 30\alpha & \cos 30\alpha \end{bmatrix}$$

$$A^{30} = \begin{bmatrix} 1 & 0 \\ 0 & 1 \end{bmatrix} = I$$

$$A^{25} = A$$

$$A^{25} - A = 0$$

Question75

Let $P(x_0, y_0)$ be the point on the hyperbola $3x^2 - 4y^2 = 36$, which is nearest to the line $3x + 2y = 1$. Then $\sqrt{2}(y_0 - x_0)$ is equal to :

[1-Feb-2023 Shift 2]

Options:

A. -3

B. 9

C. -9

D. 3

Answer: C

Solution:

Solution:

$$3x^2 - 4y^2 = 36 \quad 3x + 2y = 1$$

$$m = -\frac{3}{2}$$

$$m = + \frac{\sec\theta \cdot 3}{\sqrt{12} \cdot \tan\theta}$$

$$\Rightarrow \frac{3}{\sqrt{12}} \times \frac{1}{\sin\theta} = \frac{-3}{2}$$

$$\sin\theta = -\frac{1}{\sqrt{3}}$$

$$(\sqrt{12} \cdot \sec\theta, 3 \tan\theta)$$

$$\left(\sqrt{12} \cdot \frac{\sqrt{3}}{\sqrt{2}}, -3 \times \frac{1}{\sqrt{2}} \right) \Rightarrow \left(\frac{6}{\sqrt{2}}, \frac{-3}{\sqrt{2}} \right)$$



Question76

If the x-intercept of a focal chord of the parabola $y^2 = 8x + 4y + 4$ is 3 , then the length of this chord is equal to _____.

[1-Feb-2023 Shift 2]

Answer: 16

Solution:

Solution:

$$y^2 = 8x + 4y + 4$$

$$(y - 2)^2 = 8(x + 1)$$

$$y^2 = 4ax$$

$$a = 2, x = x + 1, Y = y - 2$$

focus (1, 2)

$$y - 2 = m(x - 1)$$

Put (3, 0) in the above line $m = -1$

Length of focal chord = 16

Question77

The line $x = 8$ is the directrix of the ellipse $E : \frac{x^2}{a^2} + \frac{y^2}{b^2} = 1$ with the corresponding focus (2, 0). If the tangent to E at the point P in the first quadrant passes through the point $(0, 4\sqrt{3})$ and intersects the x-axis at Q, then $(3 PQ)^2$ is equal to _____.

[1-Feb-2023 Shift 2]

Answer: 39

Solution:

Solution:

$$\frac{a}{e} = 8 \dots (1)$$

$$ae = 2 \dots (2)$$

$$8e = \frac{2}{e}$$

$$e^2 = \frac{1}{4} \Rightarrow e = \frac{1}{2}$$

$$a = 4$$

$$b^2 = a^2(1 - e^2)$$

$$= 16 \left(\frac{3}{4} \right) = 12$$

$$\frac{x \cos \theta}{4} + \frac{y \sin \theta}{2\sqrt{3}} = 1$$

$$\sin \theta = \frac{1}{2}$$

$$\theta = 30^\circ$$

$$P(2\sqrt{3}, \sqrt{3})$$

$$Q\left(\frac{8}{\sqrt{3}}, 0\right)$$

$$(3PQ)^2 = 39$$

Question 78

If the area of the region $S = \{(x, y) : 2y - y^2 \leq x^2 \leq 2y, x \geq y\}$ is equal to $\frac{n+2}{n+1} - \frac{\pi}{n-1}$, then the natural number n is equal to _____.

[6-Apr-2023 shift 1]

Answer: 5

Solution:

Solution:

$$x^2 + y^2 - 2y \geq 0 \quad x^2 - 2y \leq 0, \quad x \geq y$$

$$\text{Hence required area} = \frac{1}{2} \times 2 \times 2 - \int_0^2 \frac{x^2}{2} dx - \left(\frac{\pi}{4} - \frac{1}{2} \right)$$

$$= \frac{7}{6} - \frac{\pi}{4} \Rightarrow n = 5$$

Question79

The area bounded by the curves $y = |x - 1| + |x - 2|$ and $y = 3$ is equal to :

[6-Apr-2023 shift 2]

Options:

A. 5

B. 4

C. 6

D. 3

Answer: B

Solution:

Solution:

$$y = |x - 1| + |x - 2|$$

$$A = \frac{1}{2}[1 + 3][2]$$

$$= 4$$

Ans. Option 2

Question80

The area of the region $\{(x, y) : x^2 \leq y \leq 8 - x^2, y \leq 7\}$ is.

[8-Apr-2023 shift 1]

Options:

A. 24

B. 21

C. 20

D. 18

Answer: C

Solution:

Solution:

$$y \geq x^2 \quad y \leq 8 - x^2 \quad y \leq 7$$

$$x^2 = 8 - x^2$$

$$x^2 = 4$$

$$x = \pm 2$$

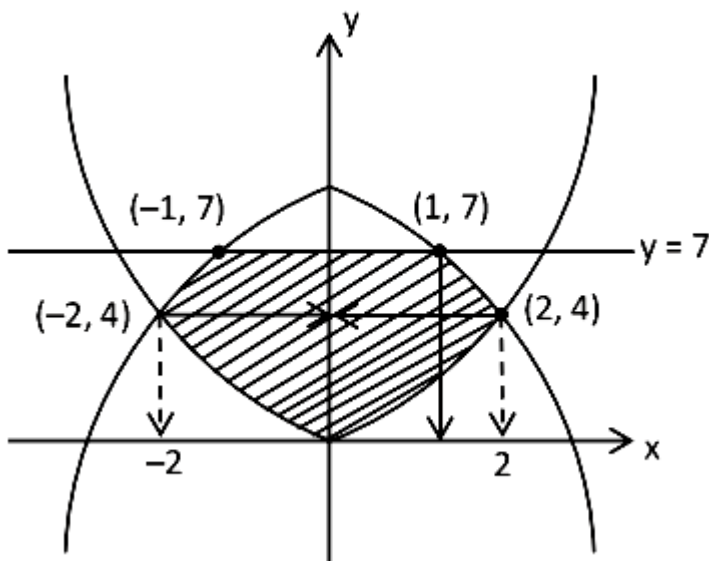

$$\begin{aligned} & 2 \left(1 \cdot 7 + \int_1^2 (8 - 2x^2) dx \right) - 2 \int_0^1 (x^2) dx \\ &= 2 \left[7 + \left(8x - \frac{2x^3}{3} \right) \Big|_1^2 \right] - 2 \left(\frac{x^3}{3} \right) \Big|_0^1 \\ &= 2 \left[7 + \left(16 - \frac{16}{3} \right) - \left(8 - \frac{2}{3} \right) \right] - 2 \left(\frac{1}{3} \right) \\ &= 2 \left[7 + \frac{32}{3} - \frac{22}{3} \right] = 2 \left[7 + \frac{10}{3} \right] = \frac{60}{3} = 20 \end{aligned}$$

Question 81

Let the area enclosed by the lines $x + y = 2$, $y = 0$ and the curve $f(x) = \min \left\{ x^2 + \frac{3}{4}, 1 + [x] \right\}$ where $[x]$ denotes the greatest integer $\leq x$, be A. Then the value of $12A$ is _____.

[8-Apr-2023 shift 2]

Answer: 17

Solution:

Solution:

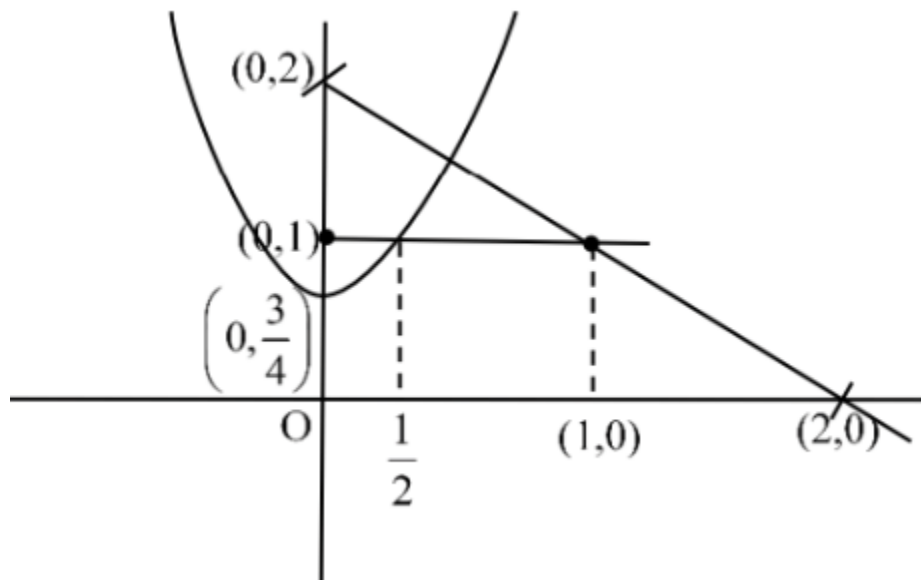

$$\frac{1}{2} \int_0^{\frac{1}{2}} \left(x^2 + \frac{3}{4} \right) dx + \frac{1}{2} \times \left(\frac{3}{2} + \frac{1}{2} \right) \times 1$$

$$= \left[\frac{x^3}{3} + \frac{3x}{4} \right]_0^{\frac{1}{2}} + 1$$

$$A = \frac{1}{24} + \frac{3}{8} + 1$$

$$12A = \frac{1}{2} + \frac{36}{8} + 12$$

$$= \frac{1}{2} + \frac{9}{2} + 12$$

$$= 5 + 12$$

$$= 17$$

Question82

Let $y = p(x)$ be the parabola passing through the points $(-1, 0)$, $(0, 1)$ and $(1, 0)$. If the area of the region

$\{(x, y) : (x + 1)^2 + (y - 1)^2 \leq 1, y \leq p(x)\}$ is A , then $12(\pi - 4A)$ is equal to

[10-Apr-2023 shift 1]

Answer: 16

Solution:

Solution:

There can be infinitely many parabolas through given points.

Let parabola $x^2 = -4a(y - 1)$

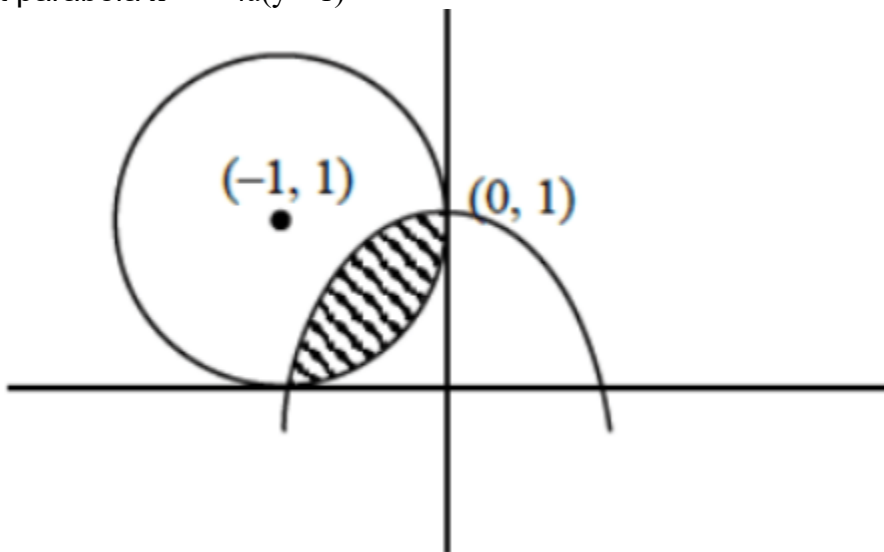

Passes through $(1, 0)$

$$\therefore b = -4a(-1) \Rightarrow a = \frac{1}{4}$$

$$\therefore x^2 = -(y - 1)$$

Now area covered by parabola $= \int_{-1}^0 (1 - x^2) dx$

$$= \left(x - \frac{x^3}{3} \right)_{-1}^0 = (0 - 0) - \left\{ -1 + \frac{1}{3} \right\}$$

$$= \frac{2}{3}$$

Required Area = Area of sector - { Area of square - Area covered by Parabola }



$$\begin{aligned}
&= \frac{\pi}{4} - \left\{ 1 - \frac{2}{3} \right\} \\
&= \frac{\pi}{4} - \frac{1}{3} \\
\therefore 12(\pi - 4A) &= 12 \left[\pi - 4 \left(\frac{\pi}{4} - \frac{1}{3} \right) \right] \\
&= 12 \left[\pi - \pi + \frac{4}{3} \right] \\
&= 16
\end{aligned}$$

Question83

If the area of the region $\{(x, y) : |x^2 - 2| \leq x\}$ is A , then $6A + 16\sqrt{2}$ is equal to _____.
 [10-Apr-2023 shift 2]

Answer: 27

Solution:

Solution:

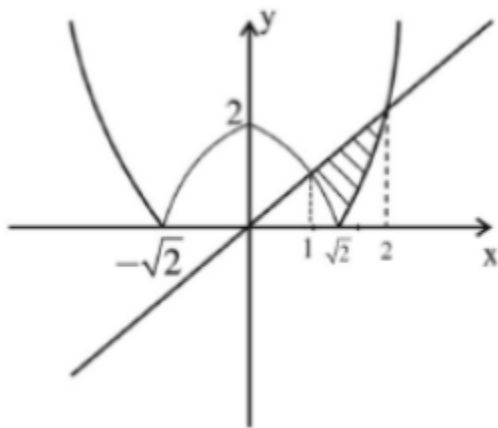

$$\begin{aligned}
A &= \int_{-\sqrt{2}}^{\sqrt{2}} (x - (2 - x^2)) dx + \int_{\sqrt{2}}^2 (x - (x^2 - 2)) dx \\
&= \left(1 - 2\sqrt{2} + \frac{2\sqrt{2}}{3} \right) - \left(\frac{1}{2} - 2 + \frac{1}{3} \right) + \left(2 - \frac{8}{3} + 4 \right) - \left(1 - \frac{2\sqrt{2}}{3} + 2\sqrt{2} \right) \\
&= -4\sqrt{2} + \frac{4\sqrt{2}}{3} + \frac{7}{6} + \frac{10}{3} = \frac{-8\sqrt{2}}{3} + \frac{9}{2}
\end{aligned}$$

$$6A = -16\sqrt{2} + 27 \therefore 6A + 16\sqrt{2} = 27$$

Ans. 27

Question84

Area of the region $\{(x, y) : x^2 + (y - 2)^2 \leq 4, x^2 \geq 2y\}$ is :
[11-Apr-2023 shift 1]

Options:

A. $\pi + \frac{8}{3}$

B. $2\pi + \frac{16}{3}$

C. $2\pi - \frac{16}{3}$

D. $\pi - \frac{8}{3}$

Answer: C

Solution:

Solution:

$$x^2 + (y - 2)^2 \leq 2^2 \text{ and } x^2 \geq 2y$$

Solving circle and parabola simultaneously:

$$2y + y^2 - 4y + 4 = 4$$

$$y^2 - 2y = 0$$

$$y = 0, 2$$

$$\text{Put } y = 2 \text{ in } x^2 = 2y \rightarrow x = \pm 2$$

$$\Rightarrow (2, 2) \text{ and } (-2, 2)$$

$$= 2 \times 2 - \frac{1}{4} \cdot \pi \cdot 2^2 = 4 - \pi$$

$$\text{Required area} = 2 \left[\int_0^2 \frac{x^2}{2} dx - (4 - \pi) \right]$$

$$= 2 \left[\frac{4}{3} + \pi - 4 \right]$$

$$= 2 \left[\pi - \frac{8}{3} \right]$$
$$= 2\pi - \frac{16}{6}$$

Question85

The area of the region enclosed by the curve $y = x^3$ and its tangent at the point $(-1, -1)$ is
[12-Apr-2023 shift 1]

Options:

- A. $\frac{23}{4}$
- B. $\frac{19}{4}$
- C. $\frac{31}{4}$
- D. $\frac{27}{4}$

Answer: D

Solution:

Solution:

equation of tangent: $y + 1 = 3(x + 1)$

i.e. $y = 3x + 2$

Point of intersection with curve $(2, 8)$

$$\text{So Area} = \int_{-1}^2 ((3x + 2) - x^3) dx = \frac{27}{4}$$

Question86

The area of the region enclosed by the curve $f(x) = \max\{\sin x, \cos x\}$, $-\pi \leq x \leq \pi$ and the x-axis is
[13-Apr-2023 shift 1]

Options:

A. $2\sqrt{2}(\sqrt{2} + 1)$

B. $4(\sqrt{2})$

C. 4

D. $2(\sqrt{2} + 1)$

Answer: C

Solution:

Solution:

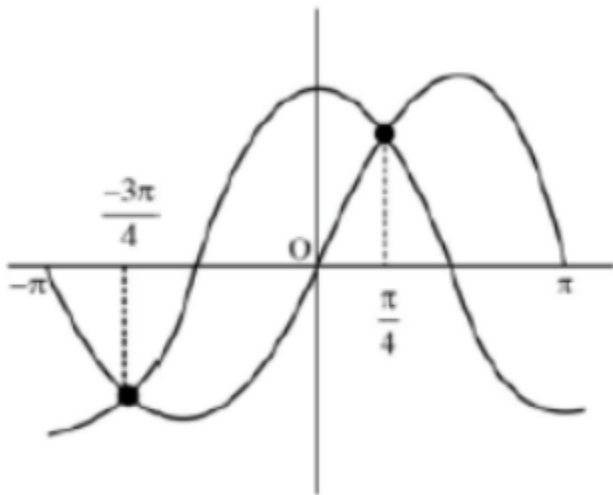

Area =

$$\left| \int_{-\pi}^{-\frac{3\pi}{4}} \sin x \, dx \right| + \left| \int_{-\frac{3\pi}{4}}^{\frac{\pi}{4}} \cos x \, dx \right| + \left| \int_{\frac{\pi}{4}}^{\pi} \cos x \, dx \right| + \left| \int_{\frac{\pi}{4}}^{\pi} \sin x \, dx \right| = 4$$

Question 87

The area of the region $\{(x, y) : x^2 \leq y \leq |x^2 - 4|, y \geq 1\}$ is:
[13-Apr-2023 shift 2]

Options:

A. $\frac{3}{4}(4\sqrt{2} + 1)$



B. $\frac{4}{3}(4\sqrt{2} - 1)$

C. $\frac{3}{4}(4\sqrt{2} - 1)$

D. $\frac{4}{3}(4\sqrt{2} + 1)$

Answer: B

Solution:

Solution:

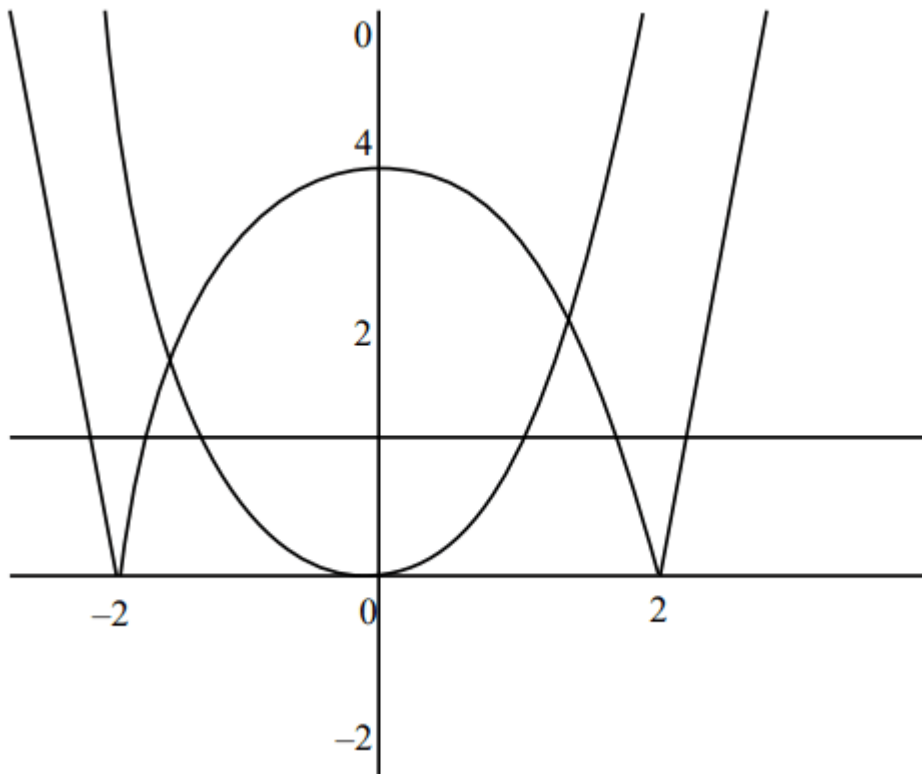

$$\text{Required area} = 2 \left[\int_1^2 \sqrt{y} dy + \int_2^4 \sqrt{4-y} dy \right] = \frac{4}{3}[4\sqrt{2} - 1]$$

Question88

If the area bounded by the curve $2y^2 = 3x$, lines $x + y = 3$, $y = 0$ and outside the circle $(x - 3)^2 + y^2 = 2$ is A , then $4(\pi + 4A)$ is equal to

[15-Apr-2023 shift 1]

Answer: 42

Solution:

Solution:

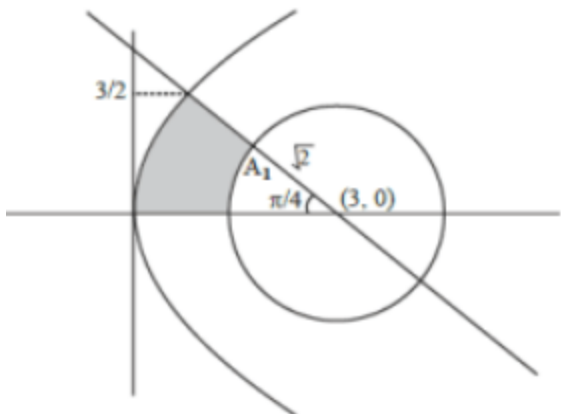

$$y^2 = \frac{3x}{2}, x + y = 3, y = 0$$

$$2y^2 = 3(3 - y)$$

$$2y^2 + 3y - 9 = 0$$

$$2y^2 - 3y + 6y - 9 = 0$$

$$(2y - 3)(y + 2) = 0; y = 3/2$$

$$\text{Area} \left(\int_0^{\frac{3}{2}} (x_R - x_L) dy \right) - A_1$$

$$\int_0^{\frac{3}{2}} \left((3 - y) - \frac{2y^2}{3} \right) dy - \frac{\pi}{8}(2)$$

$$A = \left(3y - \frac{y^2}{2} - \frac{2y^3}{9} \right)_0^{\frac{3}{2}} - \frac{\pi}{4}$$

$$4A + \pi = 4 \left[\frac{9}{2} - \frac{9}{8} - \frac{3}{4} \right] = \frac{21}{2} = 10.50$$

$$\therefore 4(4A + \pi) = 42$$

Question89



Let $H_n : \frac{x^2}{1+n} - \frac{y^2}{3+n} = 1, n \in \mathbb{N}$. Let k be the smallest even value of n such that the eccentricity of H_k is a rational number. If l is the length of the latus rectum of H_k , then $21l$ is equal to _____.

[11-Apr-2023 shift 1]

Answer: 306

Solution:

Solution:

$$H_n \Rightarrow \frac{x^2}{1+n} - \frac{y^2}{3+n} = 1$$

$$e = \sqrt{1 + \frac{b^2}{a^2}} = \sqrt{1 + \frac{3+n}{1+n}} = \sqrt{\frac{2n+4}{n+1}}$$

$$e = \sqrt{\frac{2n+4}{n+1}}$$

$n = 48$ (smallest even value for which $e \in \mathbb{Q}$)

$$e = \frac{10}{7}$$

$$a^2 = n+1 \quad b^2 = n+3$$

$$= 49 \quad = 51$$

$$l = \text{length of LR} = \frac{2b^2}{a}$$

$$L = 2 \cdot \frac{51}{7}$$

$$l = \frac{102}{7}$$

$$21l = 306$$

Question90

Let the tangent to the parabola $y^2 = 12x$ at the point $(3, \alpha)$ be perpendicular to the line $2x + 2y = 3$. Then the square of distance of the point $(6, -4)$ from the normal to the hyperbola $\alpha^2 x^2 - 9y^2 = 9\alpha^2$ at



its point $(\alpha - 1, \alpha + 2)$ is equal to _____.
[11-Apr-2023 shift 2]

Answer: 116

Solution:

Solution:

$\because P(3, \alpha)$ lies on $y^2 = 12x$

$\Rightarrow \alpha = \pm 6$

But, $\frac{dy}{dx}|_{(3, \alpha)} = \frac{6}{\alpha} = 1 \Rightarrow \alpha = 6$ ($\alpha = -6$ reject)

Now, hyperbola $\frac{x^2}{9} - \frac{y^2}{36} = 1$, normal at

$Q(\alpha - 1, \alpha + 2)$ is $\frac{9x}{5} + \frac{36y}{8} = 45$

$\Rightarrow 2x + 5y - 50 = 0$

Now, distance of $(6, -4)$ from $2x + 5y - 50 = 0$ is equal to

$$\left| \frac{2(6) - 5(4) - 50}{\sqrt{2^2 + 5^2}} \right| = \frac{58}{\sqrt{29}}$$

\Rightarrow Square of distance = 116

Question91

Let m_1 , and m_2 be the slopes of the tangents drawn from the point $P(4, 1)$ to the hyperbola $H : \frac{y^2}{25} - \frac{x^2}{16} = 1$. If Q is the point from which the tangents drawn to H have slopes $|m_1|$ and $|m_2|$ and they make positive intercepts α and β on the x -axis, then $\frac{(PQ)^2}{\alpha\beta}$ is equal to _____.
[13-Apr-2023 shift 1]

Answer: 8

Solution:

Solution:

Equation of tangent to the hyperbola $\frac{y^2}{a^2} - \frac{x^2}{b^2} = 1$

$$y = mx \pm \sqrt{a^2 - b^2 m^2}$$

passing through (4, 1)

$$1 = 4m \pm \sqrt{25 - 16m^2} \Rightarrow 4m^2 - m - 3 = 0$$

$$\Rightarrow m = 1, \frac{-3}{4}$$

Equation of tangent with positive slopes 1 & $\frac{3}{4}$

$$4y = 3x - 16$$

$y = x - 3$ } with positive intercept on x-axis.

$$\alpha = \frac{16}{3}, \beta = 3$$

Intersection points:

$$Q : (-4, -7)$$

$$P : (4, 1)$$

$$PQ^2 = 128$$

$$\frac{P^2}{\alpha\beta} = \frac{128}{16} = 8$$

Question92

The foci of a hyperbola are $(\pm 2, 0)$ and its eccentricity is $\frac{3}{2}$. A tangent, perpendicular to the line $2x + 3y = 6$, is drawn at a point in the first quadrant on the hyperbola. If the intercepts made by the tangent on the x and y axes are a and b respectively, then $|6a| + |5b|$ is equal to

[13-Apr-2023 shift 2]

Answer: 12

Solution:

$$2ae = 4$$

$$2a \left(\frac{3}{2} \right) = 4$$

$$\Rightarrow a = \frac{4}{3}$$

$$e^2 = 1 + \frac{b^2}{a^2}$$

$$\Rightarrow \frac{9}{4} = 1 + b^2 \left(\frac{9}{16} \right)$$

$$\Rightarrow b^2 = \left(\frac{5}{4} \right) \left(\frac{16}{9} \right) = \frac{20}{9}$$

slope of tangent $m = \frac{3}{2}$ equation of tangent is

$$y = mx \pm \sqrt{a^2 m^2 - b^2}$$

$$y = \frac{3}{2}x \pm \sqrt{\frac{16}{9} \left(\frac{9}{4} \right) - \frac{20}{9}}$$

$$\Rightarrow y = \frac{3x}{2} \pm \frac{4}{3}$$

$$y = 0 \Rightarrow a = \pm \frac{8}{9}$$

$$x = 0 \Rightarrow b = \pm \frac{4}{3}$$

$$|6a| + |5b| = \frac{16}{3} + \frac{20}{3} = 12$$

Question93

A circle passing through the point $P(\alpha \cdot \beta)$ in the first quadrant touches the two coordinate axes at the points A and B. The point P is above the line AB. The point Q on the line segment AB is the foot of perpendicular from P on AB. If PQ is equal to 11 units, then value of $\alpha\beta$ is _____.

[6-Apr-2023 shift 1]

Answer: 121

Solution:

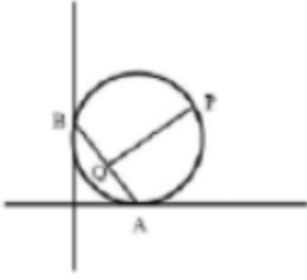

Let equation of circle is $(x - a)^2 + (y - a)^2 = a^2$

which is passing through $P(\alpha, \beta)$

then $(\alpha - a)^2 + (\beta - a)^2 = a^2$

$$\alpha^2 + \beta^2 - 2\alpha a - 2\beta a + a^2 = 0$$

Here equation of AB is $x + y = a$

Let $Q(\alpha', \beta')$ be foot of perpendicular of P on AB

$$\frac{\alpha' - \alpha}{1} = \frac{\beta' - \beta}{1} = \frac{-(\alpha + \beta - a)}{2}$$

$$PQ^2 = (\alpha' - \alpha)^2 + (\beta' - \beta)^2 = \frac{1}{4}(\alpha + \beta - a)^2 + \frac{1}{4}(\alpha + \beta - a)^2$$

$$121 = \frac{1}{2}(\alpha + \beta - a)^2$$

$$242 = \alpha^2 + \beta^2 - 2\alpha a - 2\beta a + a^2 + 2\alpha\beta$$

$$242 = 2\alpha\beta$$

$$\Rightarrow \alpha\beta = 121$$

Question94

If the tangents at the points P and Q are the circle $x^2 + y^2 - 2x + y = 5$

meet at the point $R\left(\frac{9}{4}, 2\right)$, then the area of the triangle PQR is :

[6-Apr-2023 shift 2]

Options:

A. $\frac{5}{4}$

B. $\frac{13}{4}$

C. $\frac{5}{8}$

D. $\frac{13}{8}$

Answer: C

Solution:

Solution:

$$x^2 + y^2 - 2x + y = 5$$

with respect to RPQ is x C.O.C eqⁿ of C.O.C is xT = 0

$$\frac{9}{4}x + 2y - \left(x + \frac{9}{4}\right) + \frac{1}{2}(y + 2) - 5 = 0$$

$$\frac{5}{4}x + \frac{5}{2}y - \frac{25}{4} = 0$$

$$5x + 10y - 25 = 0$$

$$x + 2y = 5$$

$$\text{Area} = \frac{1}{2}(P')(PQ) \quad (PQ) = 2\sqrt{r^2 - p^2} = \sqrt{5}$$

$$= \frac{1}{2} \left[\frac{\sqrt{5}}{4} \right] (\sqrt{5}) \quad P' = \frac{\frac{9}{4} + 4 - 5}{\sqrt{5}}$$

$$= \frac{5}{8} = \left(\frac{5}{4\sqrt{5}} \right) = \frac{\sqrt{5}}{4}$$

Method II

$$\text{area} = \frac{RL^3}{R^2 + L^2}$$

$$R = \frac{5}{2}$$

$$L = \sqrt{\frac{81}{16} + 4 - \frac{9}{2} + 2 - 5}$$

$$= \frac{5}{4}$$

$$\text{area} = \frac{5}{8}$$

Ans. Option 3

Question 95

Let **O** be the origin and **OP** and **OQ** be the tangents to the circle $x^2 + y^2 - 6x + 4y + 8 = 0$ at the points **P** and **Q** on it. If the circumcircle of the triangle **OPQ** passes through the point $\left(\alpha, \frac{1}{2}\right)$, then a value of α is.

[8-Apr-2023 shift 2]

Options:

A. $-\frac{1}{2}$

B. $\frac{5}{2}$

C. 1

D. $\frac{3}{2}$

Answer: A

Solution:

Solution:

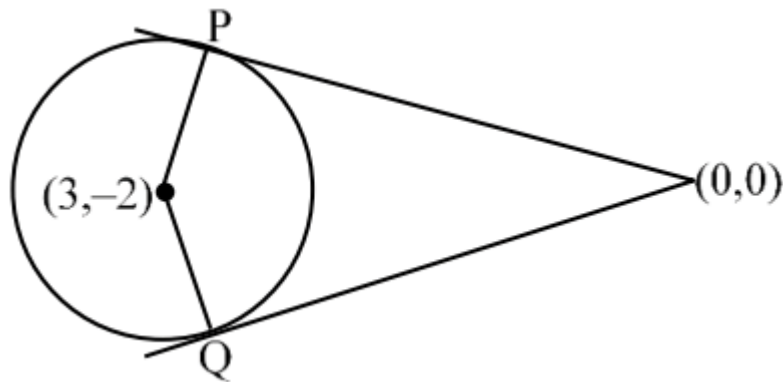

Circumcircle of $\triangle OPQ$

$$(x-0)(x-3) + (y-0)(y+2) = 0$$

$$x^2 + y^2 - 3x + 2y = 0$$

passes through $(\alpha, \frac{1}{2})$

$$\therefore \alpha^2 + \frac{1}{4} - 3\alpha + 1 = 0$$

$$\Rightarrow \alpha^2 - 3\alpha + \frac{5}{4} = 0 \Rightarrow 4\alpha^2 - 12\alpha + 5 = 0$$

$$\Rightarrow 4\alpha^2 - 10\alpha - 2\alpha + 5 = 0$$

$$(2\alpha - 1)(2\alpha - 5) = 0 \therefore \alpha = \frac{1}{2}, \frac{5}{2} \text{ Ans.}$$

Question96

If the radius of the largest circle with centre $(2, 0)$ inscribed in the ellipse $x^2 + 4y^2 = 36$ is r , then $12r^2$ is equal to

[11-Apr-2023 shift 2]

Options:

A. 69

B. 72

C. 115

D. 92

Answer: D

Solution:

Solution:

C(2, 0)

Ellipse $x^2 + 4y^2 = 36$

$$\frac{x^2}{36} + \frac{y^2}{9} = 1$$

Equation of Normal at P(6 cos θ , 3 sin θ) is $(6 \sec \theta)x - (3 \operatorname{cosec} \theta)y = 27$

It passes through (2, 0)

$$\Rightarrow \sec \theta = \frac{27}{12} = \frac{9}{4}$$

$$\cos \theta = \frac{4}{9}, \sin \theta = \frac{\sqrt{65}}{9}$$

$$P\left(\frac{8}{3}, \frac{\sqrt{65}}{3}\right)$$

$$\frac{\gamma}{P\left(\frac{8}{3}, \frac{\sqrt{65}}{3}\right)C(2, 0)}$$

$$\gamma = \sqrt{\left(\frac{8}{3} - 2\right)^2 + \left(\frac{\sqrt{65}}{3}\right)^2} = \frac{\sqrt{69}}{3}$$

$$\text{Value of } 12\gamma^2 = \left(\frac{\sqrt{69}}{3}\right)^2 \times 12$$

$$\Rightarrow \frac{12 \times 69}{9} = 92$$

Question97

Two circles in the first quadrant of radii r_1 and r_2 touch the coordinate axes. Each of them cuts off an intercept of 2 units with the line $x + y = 2$. Then $r_1^2 + r_2^2 - r_1r_2$ is equal to _____.

[12-Apr-2023 shift 1]

Answer: 7

Solution:

Solution:

$$\begin{aligned} \text{Circle } (x-a)^2 + (y-a)^2 &= a^2 \\ x^2 + y^2 - 2ax - 2ay + a^2 &= 0 \\ \text{Intercept} &= 2 \\ \Rightarrow 2\sqrt{a^2 - d^2} &= 2 \end{aligned}$$

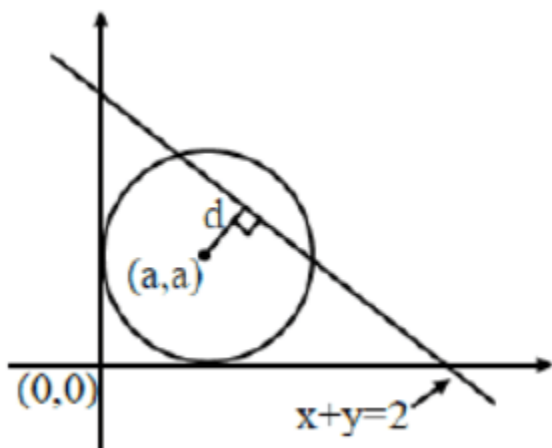

Where $d =$ perpendicular distance of centre from line $x + y = 2$

$$\begin{aligned} \Rightarrow 2\sqrt{a^2 - \left(\frac{a+a-2}{\sqrt{2}}\right)^2} &= 2 \\ \Rightarrow a^2 - \frac{(2a-2)^2}{2} &= 1 \Rightarrow 2a^2 - 4a^2 + 8a - 4 = 2 \\ \Rightarrow 2a^2 - 8a + 6 &= 0 \Rightarrow a^2 - 4a + 3 = 0 \\ \therefore r_1 + r_2 &= 4 \text{ and } r_1r_2 = 3 \\ \therefore r_1^2 + r_2^2 - r_1r_2 &= (r_1 + r_2)^2 - 3r_1r_2 \\ &= 16 - 9 = 7 \end{aligned}$$

Question98

Let the tangent and normal at the point $(3\sqrt{3}, 1)$ on the ellipse $\frac{x^2}{36} + \frac{y^2}{4} = 1$ meet the y-axis at the points A and B respectively. Let the circle C be drawn taking AB as a diameter and the line $x = 2\sqrt{5}$ intersect C at the points P and Q. If the tangents at the points P and Q on the circle intersect at the point (α, β) , then $\alpha^2 - \beta^2$ is equal to [13-Apr-2023 shift 1]

Options:

A. $\frac{304}{5}$

B. 60

C. $\frac{314}{5}$

D. 61

Answer: A

Solution:

Solution:

Given ellipse $\frac{x^2}{36} + \frac{y^2}{4} = 1$

$$\frac{x}{4\sqrt{3}} + \frac{y}{4} = 1$$

$$y = 4$$

$$\frac{x}{4} - \frac{4}{4\sqrt{3}} = \frac{2}{\sqrt{3}}$$

$$y = -8$$

$$x^2 + y^2 + 4y - 32 = 0$$

$$hx + ky + 2(y + k) - 32 = 0$$

$$k = -2$$

$$hx + 2k - 32 = 0$$

$$hx = 36$$

$$\alpha = h = \frac{36}{2\sqrt{5}}$$

$$\beta = k = -2$$

$$\alpha^2 - \beta^2 = \frac{304}{5}$$

Question99

Let the centre of a circle C be (α, β) and its radius $r < 8$. Let $3x + 4y = 24$ and $3x - 4y = 32$ be two tangents and $4x + 3y = 1$ be a normal to C . Then $(\alpha - \beta + r)$ is equal to
[13-Apr-2023 shift 2]

Options:

- A. 5
- B. 6
- C. 7
- D. 9

Answer: C

Solution:

Solution:

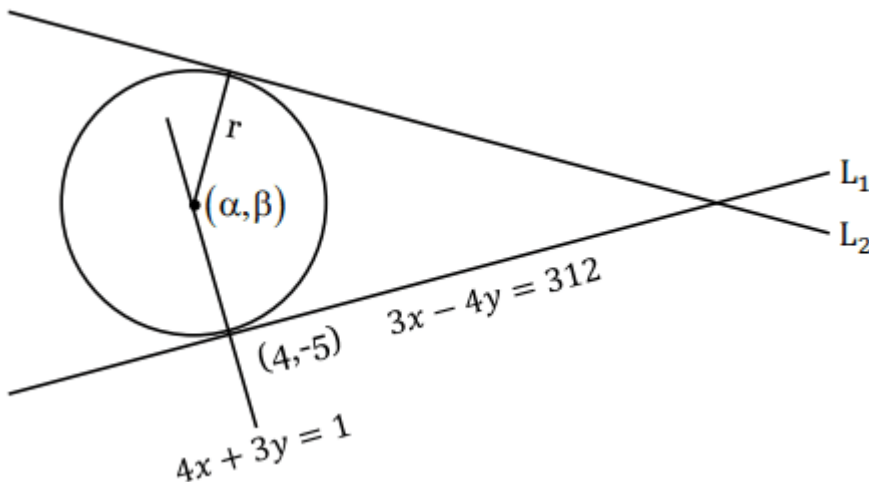

Centre lies on normal

$$\Rightarrow 4\alpha + 3\beta = 1$$

Distance of (α, β) from L_1 and L_2 are equal

$$\left| \frac{3\alpha + 4\beta - 24}{5} \right| = \left| \frac{3\alpha - 4\beta - 32}{5} \right|$$

$$3\alpha + 4\beta - 24 = -3\alpha + 4\beta + 32$$

$$\Rightarrow 6\alpha = 56$$

$$\Rightarrow \alpha = \frac{28}{3}, \beta = \frac{-109}{3}$$

$$r = \sqrt{\left(\frac{28}{3} - 4\right)^2 + \left(\frac{-109}{3} + 5\right)^2} > 8$$

(reject)

$$3\alpha + 4\beta - 24 = -3\alpha - 4\beta - 32$$

$$8\beta = -8$$

$$\beta = -1, \alpha = 1$$

$$\gamma = \sqrt{(4-1)^2 + (-5+1)^2} = 5$$

$$\alpha - \beta + \gamma = 7$$

Question100

The number of common tangents, to the circles

$$x^2 + y^2 - 18x - 15y + 131 = 0 \text{ and } x^2 + y^2 - 6x - 6y - 7 = 0, \text{ is}$$

[15-Apr-2023 shift 1]

Options:

A. 4

B. 1

C. 3

D. 2

Answer: C

Solution:

Solution:

$$C_1\left(9, \frac{15}{2}\right)r_1 = \sqrt{81 + \frac{225}{4} - 131} = \frac{5}{2}$$

$$C_2(3, 3)r_2 = 5$$

$$C_1C_2 = \sqrt{6^2 + \frac{81}{4}} = \frac{15}{2}$$

$$r_1 + r_2 = \frac{15}{2}$$

$$C_1C_2 = r_1 + r_2$$

$$\text{Number of common tangents} = 3$$

$$\text{Number of common tangents} = 3$$

Question101

Let R be the focus of the parabola $y^2 = 20x$ and the line $y = mx + c$ intersect the parabola at two points P and Q. Let the point G(10, 10) be the centroid of the triangle PQR. If $c - m = 6$, then $(PQ)^2$ is [8-Apr-2023 shift 1]

Options:

- A. 325
- B. 346
- C. 296
- D. 317

Answer: A

Solution:

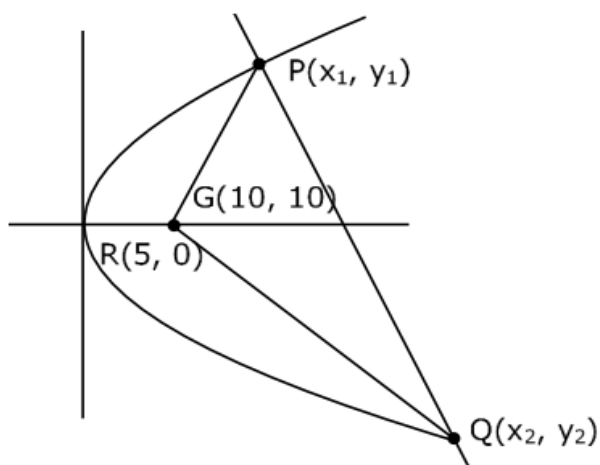

$$y^2 = 20x, y = mx + c$$

$$y^2 = 20 \left(\frac{y-c}{m} \right)$$

$$y^2 - \frac{20y}{m} + \frac{20c}{m} = 0 \quad \frac{y_1 + y_2 + y_3}{3} = 10$$

$$\frac{20}{m} = 30$$

$$m = 2/3$$

$$\text{and } c - m = 6$$

$$c = \frac{2}{3} + 6 \Rightarrow \frac{20}{3} = c$$

$$y^2 - 30y + \frac{20 \times 20/3}{2/3} = 0 \Rightarrow y^2 - 30y + 200 = 0$$

$$y = 10, y = 20$$

$$y = 20, x = 20 \quad P(5, 10); (20, 20)Q$$

$$\frac{20 + 5 + x}{3} = 10 \Rightarrow x = 5 \quad P^2 = 15^2 + 10^2 = 225 + 100 = 325$$

Question102

The ordinates of the points P and Q on the parabola with focus (3,0) and directrix $x = -3$ are in the ratio 3 : 1. If R(α , β) is the point of intersection of the tangents to the parabola at P and Q, then $\frac{\beta^2}{\alpha}$ is equal to

[8-Apr-2023 shift 2]

Answer: 16

Solution:

Parabola is $y^2 = 12x$

Let $Q(3t^2, 6t)$

so $P(27t^2, 18t)$

$R(\alpha, \beta) = (at_1t_2, a(t_1 + t_2))$

$$= (3t \cdot 3t, 3(t + 3t))$$

$R(\alpha, \beta) = (9t^2, 12t)$

$R(\alpha, \beta) = (9t^2, 12t)$

$$\frac{\beta^2}{\alpha} = \frac{(12t)^2}{9t^2} = \frac{144}{9} = 16$$

Question 103

Let a common tangent to the curves $y^2 = 4x$ and $(x - 4)^2 + y^2 = 16$ touch the curves at the points P and Q.

Then $(PQ)^2$ is equal to _____.

[10-Apr-2023 shift 1]

Answer: 32

Solution:

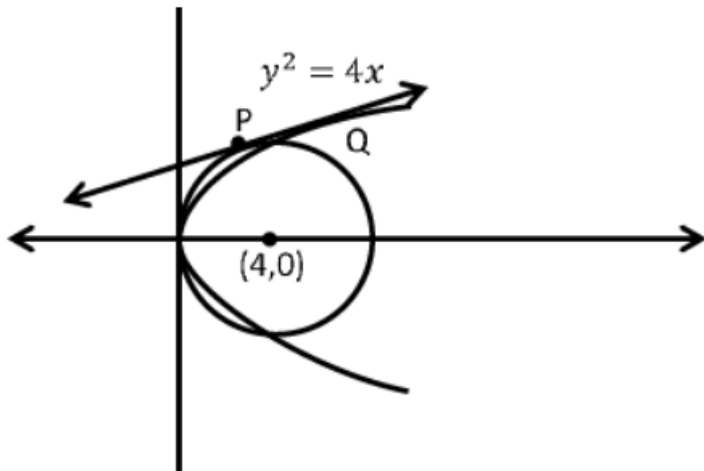

$$y^2 = 4x$$

$$(x - 4)^2 + y^2 = 16$$

Let equation of tangent of parabola

$$y = mx + 1/m$$

Now equation 1 also touches the circle

$$\therefore \left| \frac{4m + 1/m}{\sqrt{1 + m^2}} \right| = 4$$

$$(4m + 1/m)^2 = 16 + 16m^2$$

$$16m^4 + 8m^2 + 1 = 16m^2 + 16m^4$$

$$8m^2 = 1$$

$$m^2 = 1/8 \quad \{m^4 = 0\} (m \rightarrow \infty)$$

For distinct points consider only $m^2 = 1/8$.

Point of contact of parabola

$$P(8, 4\sqrt{2})$$

$$\therefore PQ = \sqrt{S_1} \Rightarrow (PQ)^2 = S_1$$

$$= 16 + 32 - 16 = 32$$

Question104

Let PQ be a focal chord of the parabola $y^2 = 36x$ of length 100, making an acute angle with the positive x-axis. Let the ordinate of P be positive and M be the point on the line segment PQ such that $PM : MQ = 3 : 1$. Then which of the following points does NOT lie on the line passing through M and perpendicular to the line PQ?

[13-Apr-2023 shift 1]

Options:

A. (3, 33)

B. (6, 29)

C. (-6, 45)

D. (-3, 43)

Answer: D

Solution:

$$9\left(t + \frac{1}{t}\right)^2 = 100$$

$$t = 3$$

$$\Rightarrow P(81, 54) \& Q(1, -6)$$

$$M(21, 9)$$

$$\Rightarrow L \text{ is } (y - 9) = \frac{-4}{3}(x - 21)$$

$$3y - 27 = -4x + 84$$

$$4x + 3y = 111$$

Question105

Let the eccentricity of an ellipse $\frac{x^2}{a^2} + \frac{y^2}{b^2} = 1$ is reciprocal to that of the hyperbola $2x^2 - 2y^2 = 1$. If the ellipse intersects the hyperbola at right angles, then square of length of the latus-rectum of the ellipse is _____ :

Answer: 2

Solution:

$$E: \frac{x^2}{a^2} + \frac{y^2}{b^2} = 1 \rightarrow e$$

$$H: x^2 - y^2 = \frac{1}{2} \Rightarrow e' = \sqrt{2}$$

$$e = \frac{1}{\sqrt{2}}$$

$$\therefore e^2 = \frac{1}{2}$$

$$1 - \frac{b^2}{a^2} = \frac{1}{2} \Rightarrow \frac{b^2}{a^2} = \frac{1}{2}$$

$$a^2 = 2b^2$$

E&H are at right angle

they are confocal

Focus of Hyperbola = focus of ellipse

$$\left(\pm \frac{1}{\sqrt{2}} \cdot \sqrt{2}, 0 \right) = \left(\pm \frac{a}{\sqrt{2}}, 0 \right)$$

$$a = \sqrt{2}$$

$$\because a^2 = 2b^2 \Rightarrow b^2 = 1$$

$$\text{Length of LR} = \frac{2b^2}{a} = \frac{2(1)}{\sqrt{2}} = \sqrt{2}$$

$$\text{Square of LR} = 2$$

Question 106

Let the ellipse $E : x^2 + 9y^2 = 9$ intersect the positive x - and y -axes at the points A and B respectively. Let the major axis of E be a diameter of the circle C . Let the line passing through A and B meet the circle C at the point P . If the area of the triangle with vertices A , P and the origin O is $\frac{m}{n}$, where m and n are coprime, then $m - n$ is equal to :

[10-Apr-2023 shift 1]

Options:

- A. 16
- B. 15
- C. 18
- D. 17

Answer: D

Solution:

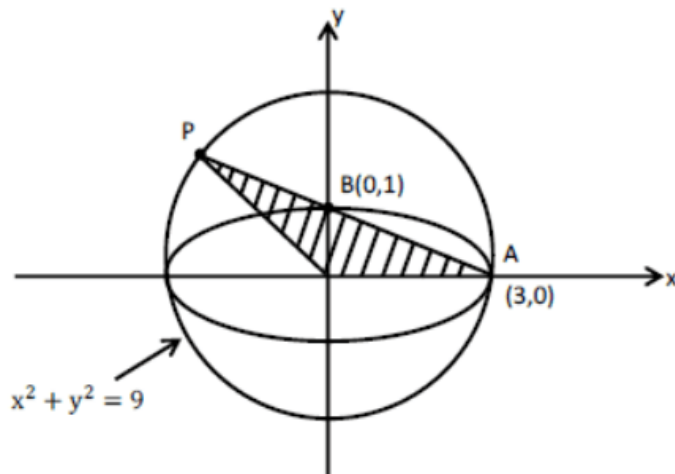

Equation of line AB or AP is

$$\frac{x}{3} + \frac{y}{1} = 1$$

$$x + 3y = 3$$

$$x = (3 - 3y)$$

Intersection point of line AP & circle is $P(x_0, y_0)$

$$x^2 + y^2 = 9 \Rightarrow (3 - 3y)^2 + y^2 = 9$$

$$\Rightarrow 3^2(1 + y^2 - 2y) + y^2 = 9$$

$$\Rightarrow 5y^2 - 9y = 0 \Rightarrow y(5y - 9) = 0$$

$$\Rightarrow y = 9/5$$

$$\text{Hence } x = 3(1 - y) = 3\left(1 - \frac{9}{5}\right) = 3\left(\frac{-4}{5}\right)$$



$$x = \frac{-12}{5}$$

$$P(x_0, y_0) = \left(\frac{-12}{5}, \frac{9}{5} \right)$$

Area of $\triangle AOP$ is $= \frac{1}{2} \times OA \times \text{height}$

$$\text{Height} = 9/5, \quad OA = 3$$

$$= \frac{1}{2} \times 3 \times \frac{9}{5} = \frac{27}{10} = \frac{m}{n}$$

Compare both side $m = 27, n = 10 \Rightarrow m - n = 17$

Therefore, correct answer is option-D

Question107

Let a circle of radius 4 be concentric to the ellipse $15x^2 + 19y^2 = 285$. Then the common tangents are inclined to the minor axis of the ellipse at the angle.

[10-Apr-2023 shift 2]

Options:

A. $\frac{\pi}{6}$

B. $\frac{\pi}{12}$

C. $\frac{\pi}{3}$

D. $\frac{\pi}{4}$

Answer: C

Solution:

$$\frac{x^2}{19} + \frac{y^2}{15} = 1$$

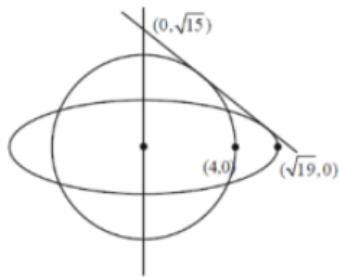

Let tang be

$$y = mx \pm \sqrt{19m^2 + 15}$$

$$mx - y \pm \sqrt{19m^2 + 15} = 0$$

Parallel from $(0, 0) = 4$

$$\left| \frac{\pm \sqrt{19m^2 + 15}}{\sqrt{m^2 + 1}} \right| = 4$$

$$19m^2 + 15 = 16m^2 + 16$$

$$3m^2 = 1$$

$$m = \pm \frac{1}{\sqrt{3}}$$

$$\theta = \frac{\pi}{6} \text{ with x-axis}$$

Required angle $\frac{\pi}{3}$.

Question108

Consider ellipse $E_k : kx^2 + ky^2 = 1, k = 1, 2, \dots, 20$. Let C_k be the circle which touches the four chords joining the end points (one on minor axis and another on major axis) of the ellipse E_k . If r_k is the radius of the circle C_k then the value of $\sum_{k=1}^{20} \frac{1}{r_k^2}$ is

[11-Apr-2023 shift 1]

Options:

- A. 3320
- B. 3210
- C. 3080
- D. 2870

Answer: C

Solution:

$$K Kx^2 + K^2 y^2 = 1$$

$$\frac{x^2}{1/K} + \frac{y^2}{1/K^2} = 1$$

Now

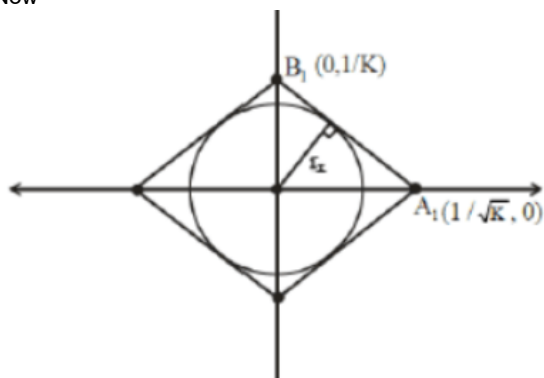

Equation of

$$A_1B_2: \frac{x}{1/\sqrt{K}} + \frac{y}{1/K} = 1 \Rightarrow \sqrt{K}x + Ky = 1$$

$$r_k = \perp r \text{ distance of } (0, 0) \text{ from line } A_1B_1$$

$$r_k = \left| \frac{(0+0-1)}{\sqrt{K+K^2}} \right| = \frac{1}{\sqrt{K+K^2}}$$

$$\frac{1}{r_k^2} = K + K^2 \Rightarrow \sum_{k=1}^{20} \frac{1}{r_k^2} = \sum_{k=1}^{20} (K + K^2)$$

$$= \sum_{k=1}^{20} K + \sum_{k=1}^{20} K^2$$

$$= \frac{20 \times 21}{2} + \frac{20 \cdot 21 \cdot 41}{6}$$

$$= 210 + 10 \times 7 \times 41$$

$$= 210 + 2870$$

$$= 3080$$

Question 109

Let $P\left(\frac{2\sqrt{3}}{\sqrt{7}}, \frac{6}{\sqrt{7}}\right)$, Q , R , and S be four points on the ellipse $9x^2 + 4y^2 = 36$. Let PQ and RS be mutually perpendicular and pass through the origin. If $\frac{1}{(PQ)^2} + \frac{1}{(RS)^2} = \frac{p}{q}$, where p and q are coprime, then $p + q$ is equal to

[12-Apr-2023 shift 1]

Options:

- A. 137
- B. 143
- C. 157
- D. 147

Answer: C

Solution:

Let $R(2 \cos \theta, 3 \sin \theta)$

As $OP \perp OR$

$$\text{so } \frac{3 \sin \theta}{2 \cos \theta} \times \frac{\frac{6}{\sqrt{7}}}{\frac{2\sqrt{3}}{\sqrt{7}}} = -1$$

$$\Rightarrow \tan \theta = \frac{-2}{3\sqrt{3}}$$

$$\Rightarrow R \left(\frac{-6\sqrt{3}}{\sqrt{31}}, \frac{6}{\sqrt{31}} \right) \text{ or } R \left(\frac{6\sqrt{3}}{\sqrt{31}}, \frac{-6}{\sqrt{31}} \right)$$

$$\text{Now } = \frac{1}{(PQ)^2} + \frac{1}{(RS)^2} = \frac{1}{4} \left(\frac{1}{(OP)^2} + \frac{1}{(OR)^2} \right)$$

$$= \frac{1}{4} \left(\frac{1}{48} + \frac{1}{144} \right) = \frac{1}{4} \left(\frac{7}{48} + \frac{31}{144} \right)$$

$$= \frac{13}{144}$$

$$\Rightarrow p + q = 157$$

Question 110

Let an ellipse with centre $(1, 0)$ and latus rectum of length $\frac{1}{2}$ have its major axis along x-axis. If its minor axis subtends an angle 60° at the foci, then the square of the sum of the lengths of its minor and major axes is equal to _____
[15-Apr-2023 shift 1]

Answer: 9

Solution:

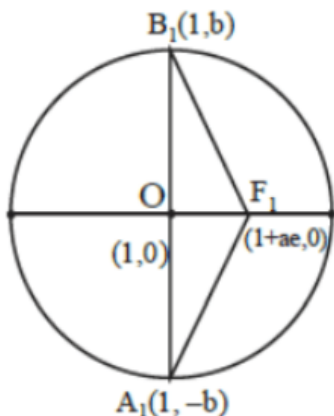

$$\text{L.R.} = \frac{2b^2}{a} = \frac{1}{2}$$

$$4b^2 = a \dots (i)$$

$$\text{Ellipse } \frac{(x-1)^2}{a^2} + \frac{y^2}{b^2} = 1$$

$$m_{B_2F_1} = \frac{1}{\sqrt{3}}$$

$$\frac{b}{ae} = \frac{1}{\sqrt{3}}$$

$$3b^2 = a^2 e^2 = a^2 - b^2$$

$$4b^2 = a^2 \dots (ii)$$

From (i) and (ii)

$$a = a^2$$

$$\therefore a = 1$$

$$b^2 = \frac{1}{4}$$

$$((2a) + (2b))^2 = 9$$

Question111

Let $x^2 + y^2 + Ax + By + C = 0$ be a circle passing through $(0, 6)$ and touching the parabola $y = x^2$ at $(2, 4)$.

Then $A + C$ is equal to

[24-Jun-2022-Shift-1]

Options:

A. 16

B. $88/5$

C. 72

D. -8

Answer: A

Solution:

For tangent to parabola $y = x^2$ at $(2, 4)$

$$\frac{dy}{dx} \Big|_{(2, 4)} = 4$$

Equation of tangent is $y - 4 = 4(x - 2)$

$$\Rightarrow 4x - y - 4 = 0$$

Family of circle can be given by

$$(x - 2)^2 + (y - 4)^2 + \lambda(4x - y - 4) = 0$$

As it passes through $(0, 6)$

$$2^2 + 2^2 + \lambda(-10) = 0$$

$$\Rightarrow \lambda = \frac{4}{5}$$

Equation of circle is

$$(x - 2)^2 + (y - 4)^2 + \frac{4}{5}(4x - y - 4) = 0$$

$$\Rightarrow (x^2 + y^2 - 4x - 8y + 20) + \left(\frac{16}{5}x - \frac{4}{5}y - \frac{16}{5} \right) = 0$$

$$A = -4 + \frac{16}{5}, C = 20 - \frac{16}{5}$$

$$\text{So, } A + C = 16$$

Question 112

Let $\lambda x - 2y = \mu$ be a tangent to the hyperbola $a^2x^2 - y^2 = b^2$. Then $\left(\frac{\lambda}{a}\right)^2 - \left(\frac{\mu}{b}\right)^2$ is equal to:

[24-Jun-2022-Shift-1]

Options:

A. -2

B. -4

C. 2

D. 4

Answer: D

Solution:

$$\frac{x^2}{\left(\frac{b^2}{a^2}\right)} - \frac{y^2}{b^2} = 1$$

Tangent in slope form $\Rightarrow y = mx \pm \sqrt{\frac{b^2}{a^2}m^2 - b^2}$

i.e., same as $y = \frac{\lambda x}{2} - \frac{\mu}{2}$

Comparing coefficients,

$$m = \frac{\lambda}{2}, \quad \frac{b^2}{a^2}m^2 - b^2 = \frac{\mu^2}{4}$$

Eliminating m , $\frac{b^2}{a^2} \cdot \frac{\lambda^2}{4} - b^2 = \frac{\mu^2}{4}$

$$\Rightarrow \frac{\lambda^2}{a^2} - \frac{\mu^2}{b^2} = 4$$

Question 113

If two tangents drawn from a point (α, β) lying on the ellipse $25x^2 + 4y^2 = 1$ to the parabola $y^2 = 4x$ are such that the slope of one tangent is four times the other, then the value of $(10\alpha + 5)^2 + (16\beta^2 + 50)^2$ equals [24-Jun-2022-Shift-1]

Answer: 2929

Solution:

$\because (\alpha, \beta)$ lies on the given ellipse, $25\alpha^2 + 4\beta^2 = 1 \dots (i)$

Tangent to the parabola, $y = mx + \frac{1}{m}$ passes through (α, β) . So, $\alpha m^2 - \beta m + 1 = 0$ has

$$m_1 + 4m_1 = \frac{\beta}{\alpha} \text{ and } m_1 \cdot 4m_1 = \frac{1}{\alpha}$$

Gives that $4\beta^2 = 25\alpha \dots (ii)$

from (i) and (ii)

$$25(\alpha^2 + \alpha) = 1 \dots (iii)$$

Now, $(10\alpha + 5)^2 + (16\beta^2 + 50)^2$

$$= 25(2\alpha + 1)^2 + 2500(2\alpha + 1)^2$$

$$= 2525(4\alpha^2 + 4\alpha + 1) \text{ from equation (iii)}$$

$$= 2525 \left(\frac{4}{25} + 1 \right)$$

$$= 2929$$

Get More Learning Materials Here :



CLICK HERE 



www.studentbro.in

Question114

Let S be the region bounded by the curves $y = x^3$ and $y^2 = x$. The curve $y = 2|x|$ divides S into two regions of areas R_1, R_2 . If $\max\{R_1, R_2\} = R_2$, then $\frac{R_2}{R_1}$ is equal to
[24-Jun-2022-Shift-1]

Answer: 19

Solution:

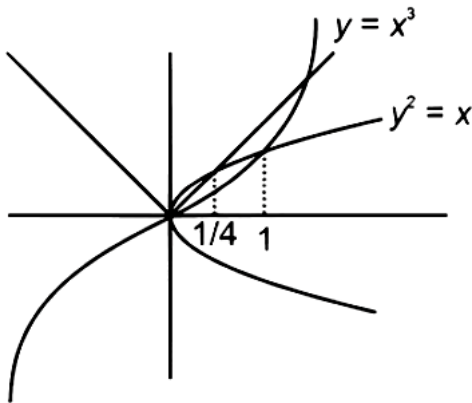

$$C_1 : y = x^3$$

$$C_2 : y^2 = x$$

$$\text{and } C_3 = y = 2|x|$$

C_1 and C_2 intersect at $(1, 1)$

C_2 and C_3 intersect at $(\frac{1}{4}, \frac{1}{2})$

$$\text{Clearly } R_1 = \int_0^{1/4} (\sqrt{x} - 2x) dx = \frac{2}{3} \left(\frac{1}{8} \right) - \frac{1}{16} = \frac{1}{48}$$

$$\text{and } R_1 + R_2 = \int_0^1 (\sqrt{x} - x^3) dx = \frac{2}{3} - \frac{1}{4} = \frac{5}{12}$$

$$\text{So, } \frac{R_1 + R_2}{R_1} = \frac{5/12}{1/48} \Rightarrow 1 + \frac{R_2}{R_1} = 20$$

$$\Rightarrow \frac{R_2}{R_1} = 19$$

Question115

The area (in sq. units) of the region enclosed between the parabola $y^2 = 2x$ and the line $x + y = 4$ is ____
[24-Jun-2022-Shift-2]

Answer: 18

Solution:

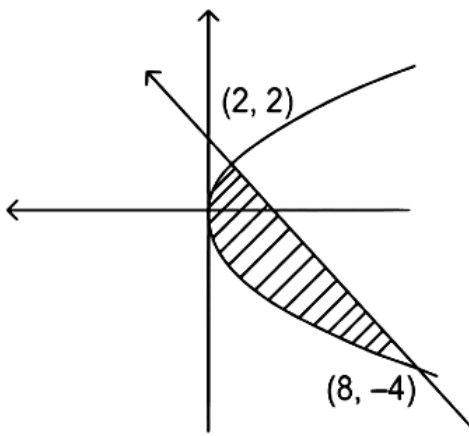

The required area = $\int_{-4}^2 \left(4 - y - \frac{y^2}{2}\right) dy$

$$= \left[4y - \frac{y^2}{2} - \frac{y^3}{6}\right]_{-4}^2$$

= 18 square units

Question 116

The area of the region enclosed between the parabolas $y^2 = 2x - 1$ and $y^2 = 4x - 3$ is
[25-Jun-2022-Shift-2]

Options:

A. $\frac{1}{3}$

B. $\frac{1}{6}$

C. $\frac{2}{3}$

D. $\frac{3}{4}$

Answer: A

Solution:

Area of the shaded region

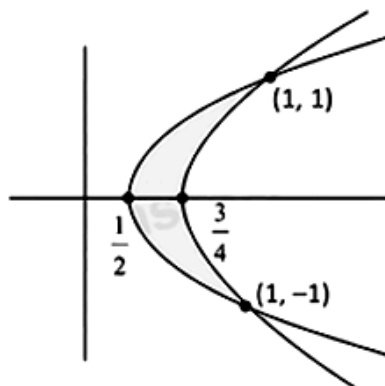

$$= 2 \int_0^1 \left(\frac{y^2+3}{4} - \frac{y^2+1}{2} \right) dy$$

$$= 2 \int_0^1 \left(\frac{1}{4} - \frac{y^2}{4} \right) dy$$

$$= 2 \left[\frac{1}{4} - \frac{1}{12} \right] = \frac{1}{3}$$

Question117

The area bounded by the curve $y = |x^2 - 9|$ and the line $y = 3$ is :
[26-Jun-2022-Shift-1]

Options:

- A. $4(2\sqrt{3} + \sqrt{6} - 4)$
- B. $4(4\sqrt{3} + \sqrt{6} - 4)$
- C. $8(4\sqrt{3} + 3\sqrt{6} - 9)$
- D. $8(4\sqrt{3} + \sqrt{6} - 9)$

Answer: D

Solution:

$$y = 3 \text{ and } y = |x^2 - 9|$$

Intersect in first quadrant at $x = \sqrt{6}$ and $x = \sqrt{12}$

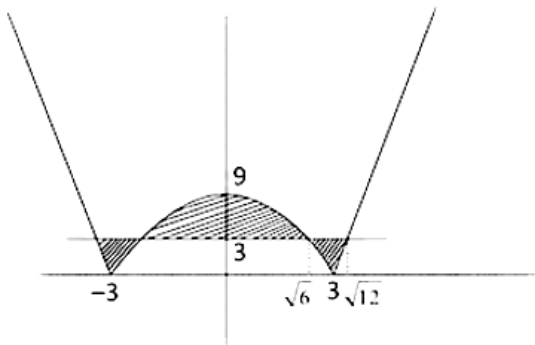

Required area

$$\begin{aligned} &= 2 \left[\frac{2}{3}(6 \times \sqrt{6}) + \int_{\sqrt{6}}^3 (3 - (9 - x^2)) dx + \int_3^{\sqrt{12}} (3 - (x^2 - 9)) dx \right] \\ &= 2 \left[4\sqrt{6} + \left(\frac{x^3}{3} - 6x \right) \Big|_{\sqrt{6}}^3 + \left(12x - \frac{x^3}{3} \right) \Big|_3^{\sqrt{12}} \right] \\ &= 2[4\sqrt{6} + (4\sqrt{6} - 9) + (8\sqrt{12} - 27)] \\ &= 2[8\sqrt{6} + 16\sqrt{3} - 36] = 8[2\sqrt{6} + 4\sqrt{3} - 9] \end{aligned}$$

Question118

The area of the region bounded by $y^2 = 8x$ and $y^2 = 16(3 - x)$ is equal to:
[26-Jun-2022-Shift-2]

Options:

- A. $\frac{32}{3}$
- B. $\frac{40}{3}$
- C. 16
- D. 19

Answer: C

Solution:

$$c_1 : y^2 = 8x$$

$$c_2 : y^2 = 16(3-x)$$

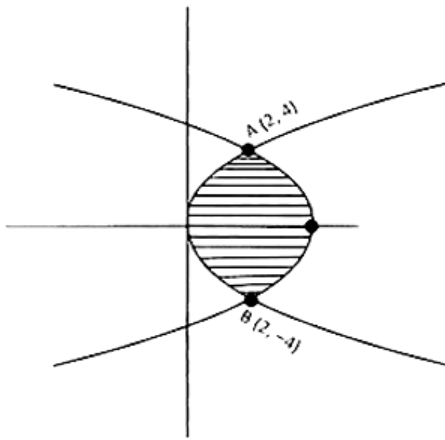

Solving c_1 and c_2

$$48 - 16x = 8x$$

$$x = 2$$

$$\therefore y = \pm 4$$

\therefore Area of shaded region

$$= 2 \int_0^4 \left\{ \left(\frac{48-y^2}{16} \right) - \left(\frac{y^2}{8} \right) \right\} dy$$

$$= \frac{1}{8} [48y - y^3]_0^4 = 16$$

Question 119

Let

$$A_1 = \{(x, y) : |x| \leq y^2, |x| + 2y \leq 8\} \text{ and}$$

$$A_2 = \{(x, y) : |x| + |y| \leq k\}.$$

If $27(\text{Area } A_1) = 5(\text{Area } A_2)$, then k is equal to :

[27-Jun-2022-Shift-1]

Answer: 6

Solution:

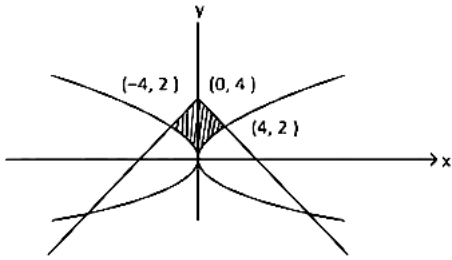

Required area (above x-axis)

$$A_1 = 2 \int_0^4 \left(\frac{8-x}{2} - \sqrt{x} \right) dx$$

$$= 2 \left(16 - \frac{16}{4} - \frac{8}{3/2} \right) = \frac{40}{3}$$

$$\text{and } A_2 = 4 \left(\frac{1}{2} \cdot k^2 \right) = 2k^2$$

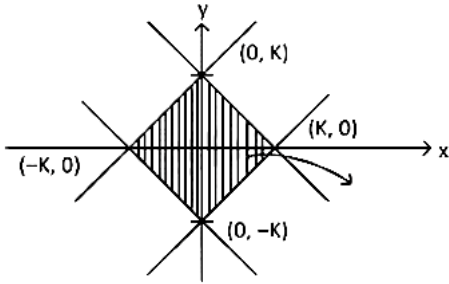

$$\therefore 27 \cdot \frac{40}{3} = 5 \cdot (2k^2)$$

$$\Rightarrow k = 6$$

Question 120

If the area of the region $\left\{ (x, y) : x^{\frac{2}{3}} + y^{\frac{2}{3}} \leq 1, x + y \geq 0, y \geq 0 \right\}$ is A , then $\frac{256A}{\pi}$ is equal to _____
 [27-Jun-2022-Shift-2]

Answer: 36

Solution:

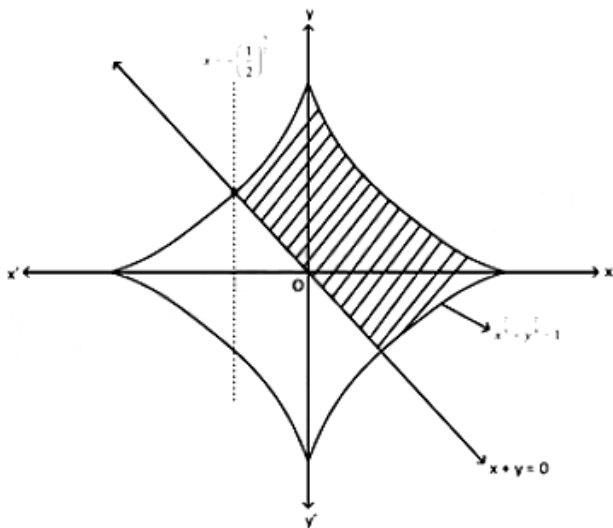

∴ Area of shaded region

$$= \int_{-\frac{1}{2}}^{\frac{3}{2}} \left(\frac{3}{2} - \left(1-x\right)^{\frac{2}{3}} + x \right) dx + \int_{\frac{3}{2}}^{\frac{3}{2}} dx$$

$$= \int_{-\frac{1}{2}}^{\frac{3}{2}} \left(\frac{3}{2} - \left(1-x\right)^{\frac{2}{3}} \right) dx + \int_{\frac{3}{2}}^{\frac{3}{2}} x dx$$

$$= \left[\frac{3}{2}x - \frac{3}{5} \left(1-x\right)^{\frac{5}{3}} \right]_{-\frac{1}{2}}^{\frac{3}{2}} - \left[\frac{1}{2}x^2 \right]_{\frac{3}{2}}^{\frac{3}{2}}$$

Let $x = \sin^3 \theta$

∴ $dx = 3\sin^2 \theta \cos \theta d\theta$

$$= \int_{-\frac{\pi}{4}}^{\frac{\pi}{2}} 3\sin^2 \theta \cos^4 \theta d\theta + \left(0 + \frac{1}{16}\right)$$

$$= \frac{9\pi}{64} + \frac{1}{16} - \frac{1}{16} = \frac{36\pi}{256} = A$$

$$\therefore \frac{256A}{\pi} = 36$$

Question 121

The area of the region $S = \{(x, y) : y^2 \leq 8x, y \geq \sqrt{2}x, x \geq 1\}$ is
[28-Jun-2022-Shift-1]

Options:

A. $\frac{13\sqrt{2}}{6}$

B. $\frac{11\sqrt{2}}{6}$

C. $\frac{5\sqrt{2}}{6}$

D. $\frac{19\sqrt{2}}{6}$

Answer: B

Solution:

Solution:

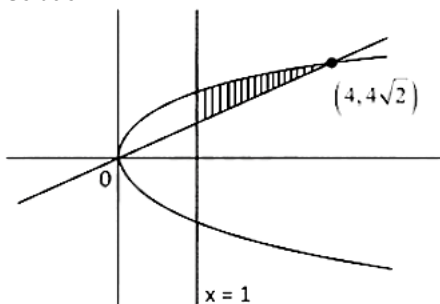

Required area

$$= \int_1^4 (\sqrt{8x} - \sqrt{2}x) dx$$

$$= \left[\frac{2\sqrt{8}}{3} x^{\frac{3}{2}} - \frac{x^2}{\sqrt{2}} \right]_1^4$$

$$= \frac{16\sqrt{3}}{3} - \frac{16}{\sqrt{2}} - \frac{2\sqrt{8}}{3} + \frac{1}{\sqrt{2}}$$

$$= \frac{11\sqrt{2}}{6} \text{ sq. units}$$

Question122

The area of the bounded region enclosed by the curve $y = 3 - \left| x - \frac{1}{2} \right| - |x + 1|$ and the x-axis is :
[28-Jun-2022-Shift-2]

Options:

- A. $\frac{9}{4}$
- B. $\frac{45}{16}$
- C. $\frac{27}{8}$
- D. $\frac{63}{16}$

Answer: C

Solution:

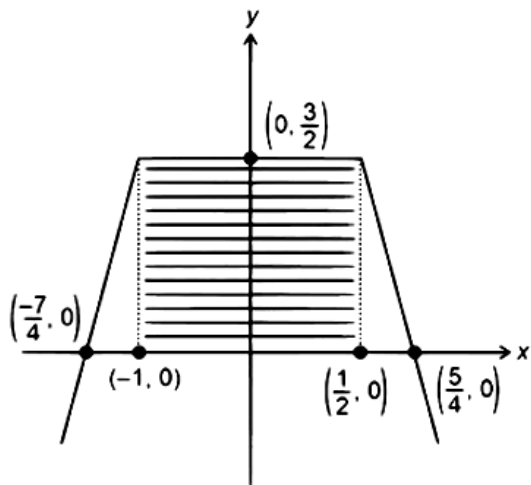

$$y = \begin{cases} 2x - \frac{7}{2} & x < -1 \\ \frac{3}{2} & -1 \leq x \leq \frac{1}{2} \\ \frac{5}{2} - 2x & x > \frac{1}{2} \end{cases}$$

$$y = 3 - \left| x - \frac{1}{2} \right| - |x + 1|$$

Area of shaded region (required area)

$$= \frac{1}{2} \left(3 + \frac{3}{2} \right) \cdot \frac{3}{2} = \frac{27}{8}$$

Question123

The area enclosed by $y^2 = 8x$ and $y = \sqrt{2}x$ that lies outside the triangle formed by $y = \sqrt{2}x$, $x = 1$, $y = 2\sqrt{2}$, is equal to:
[29-Jun-2022-Shift-1]

Options:

- A. $\frac{16\sqrt{2}}{6}$
 B. $\frac{11\sqrt{2}}{6}$
 C. $\frac{13\sqrt{2}}{6}$
 D. $\frac{5\sqrt{2}}{6}$

Answer: C

Solution:

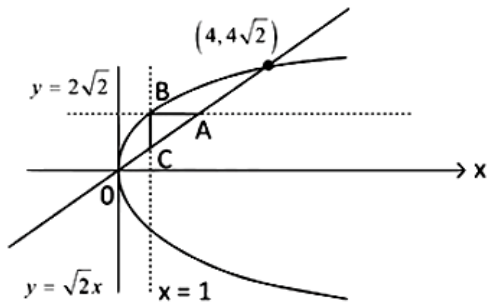

$A(2, 2\sqrt{2}), B(1, 2\sqrt{2}), C(1, \sqrt{2})$

$$\begin{aligned} \text{Area} &= \int_0^{4\sqrt{2}} \left(\frac{y}{\sqrt{2}} - \frac{y^2}{8} \right) dy - \text{area}(\Delta BAC) \\ &= \left[\frac{y^2}{2\sqrt{2}} - \frac{y^3}{24} \right]_0^{4\sqrt{2}} - \frac{1}{2} \times AB \times BC \\ &= 8\sqrt{2} - \frac{32 \times 4\sqrt{2}}{24} - \frac{1}{2} \times 1 \times \sqrt{2} \\ &= 8\sqrt{2} - \frac{16\sqrt{2}}{3} - \frac{\sqrt{2}}{2} \\ &= \frac{\sqrt{2}}{6}(48 - 32 - 3) = \frac{13\sqrt{2}}{6} \end{aligned}$$

Question 124

For real numbers $a, b (a > b > 0)$, let

$$\text{Area} \left\{ (x, y) : x^2 + y^2 \leq a^2 \text{ and } \frac{x^2}{a^2} + \frac{y^2}{b^2} \geq 1 \right\} = 30\pi \text{ and}$$

$$\text{Area} \left\{ (x, y) : x^2 + y^2 \leq b^2 \text{ and } \frac{x^2}{a^2} + \frac{y^2}{b^2} \leq 1 \right\} = 18\pi$$

Then, the value of $(a - b)^2$ is equal to _____
 [29-Jun-2022-Shift-2]

Answer: 12

Solution:

given $\pi a^2 - \pi ab = 30\pi$ and $\pi ab - \pi b^2 = 18\pi$
 on subtracting, we get $(a - b)^2 = a^2 - 2ab + b^2 = 12$

Question 125

Let the hyperbola $H : \frac{x^2}{a^2} - y^2 = 1$ and the ellipse $E : 3x^2 + 4y^2 = 12$ be such that the length of latus rectum of H is equal to the length of latus rectum of E . If e_H and e_E are the eccentricities of H and E respectively, then the value of $12(e_H^2 + e_E^2)$ is equal to
[24-Jun-2022-Shift-2]

Answer: 42

Solution:

$$\because H : \frac{x^2}{a^2} - \frac{y^2}{1} = 1$$

$$\therefore \text{Length of latus rectum} = \frac{2}{a}$$

$$E : \frac{x^2}{4} + \frac{y^2}{3} = 1$$

$$\text{Length of latus rectum} = \frac{6}{2} = 3$$

$$\therefore \frac{2}{a} = 3 \Rightarrow a = \frac{2}{3}$$

$$\therefore 12(e_H^2 + e_E^2) = 12\left(1 + \frac{9}{4}\right) + \left(1 - \frac{3}{4}\right) = 42$$

Question 126

Let the eccentricity of the hyperbola $\frac{x^2}{a^2} - \frac{y^2}{b^2} = 1$ be $\frac{5}{4}$. If the equation of the normal at the point $\left(\frac{8}{\sqrt{5}}, \frac{12}{5}\right)$ on the hyperbola is $8\sqrt{5}x + \beta y = \lambda$, then $\lambda - \beta$ is equal to _____
[25-Jun-2022-Shift-2]

Answer: 85

Solution:

$$\frac{x^2}{a^2} - \frac{y^2}{b^2} = 1 \left(e = \frac{5}{4} \right)$$

$$\text{So, } b^2 = a^2 \left(\frac{25}{16} - 1 \right) \Rightarrow b = \frac{3}{4}a$$

Also $\left(\frac{8}{\sqrt{5}}, \frac{12}{5}\right)$ lies on the given hyperbola

$$\text{So, } \frac{64}{5a^2} - \frac{144}{25\left(\frac{9a^2}{16}\right)} = 1 \Rightarrow a = \frac{8}{5} \text{ and } b = \frac{6}{5}$$

Equation of normal

$$\frac{64}{25} \left(\frac{x}{8} \right) + \frac{36}{25} \left(\frac{y}{12} \right) = 4$$

$$\Rightarrow \frac{8}{5\sqrt{5}}x + \frac{3}{5}y = 4$$

$$\Rightarrow 8\sqrt{5}x + 15y = 100$$

$$\text{So, } \beta = 15 \text{ and } \lambda = 100$$

$$\text{Gives } \lambda - \beta = 85$$

Question127

The normal to the hyperbola

$\frac{x^2}{a^2} - \frac{y^2}{9} = 1$ at the point $(8, 3\sqrt{3})$ on it passes through the point :

[26-Jun-2022-Shift-2]

Options:

A. $(15, -2\sqrt{3})$

B. $(9, 2\sqrt{3})$

C. $(-1, 9\sqrt{3})$

D. $(-1, 6\sqrt{3})$

Answer: C

Solution:

Given hyperbola: $\frac{x^2}{a^2} - \frac{y^2}{9} = 1$

\therefore It passes through $(8, 3\sqrt{3})$

$$\therefore \frac{64}{a^2} - \frac{27}{9} = 1 \Rightarrow a^2 = 16$$

Now, equation of normal to hyperbola

$$\frac{16x}{8} + \frac{9y}{3\sqrt{3}} = 16 + 9$$

$$\Rightarrow 2x + \sqrt{3}y = 25 \dots\dots (i)$$

$(-1, 9\sqrt{3})$ satisfies (i)

Question128

Let a line L_1 be tangent to the hyperbola $\frac{x^2}{16} - \frac{y^2}{4} = 1$ and let L_2 be the line passing through the origin and perpendicular to L_1 . If the locus of the point of intersection of L_1 and L_2 is $(x^2 + y^2)^2 = \alpha x^2 + \beta y^2$, then $\alpha + \beta$ is equal to _____

[26-Jun-2022-Shift-2]

Answer: 12

Solution:

Equation of L_1 is

$$\frac{x \sec \theta}{4} - \frac{y \tan \theta}{2} = 1 \dots \text{(i)}$$

Equation of line L_2 is

$$\frac{x \tan \theta}{2} + \frac{y \sec \theta}{4} = 0 \dots \text{(ii)}$$

\therefore Required point of intersection of L_1 and L_2 is (x_1, y_1) then

$$\frac{x_1 \sec \theta}{4} - \frac{y_1 \tan \theta}{2} - 1 = 0 \dots \text{(iii)}$$

$$\text{and } \frac{y_1 \sec \theta}{4} + \frac{x_1 \tan \theta}{2} = 0 \dots \text{(iv)}$$

From equations (iii) and (iv)

$$\sec \theta = \frac{4x_1}{x_1^2 + y_1^2} \text{ and } \tan \theta = \frac{-2y_1}{x_1^2 + y_1^2}$$

\therefore Required locus of (x_1, y_1) is

$$(x^2 + y^2)^2 = 16x^2 - 4y^2$$

$$\therefore \alpha = 16, \beta = -4$$

$$\therefore \alpha + \beta = 12$$

Question 129

Let the eccentricity of the hyperbola $H : \frac{x^2}{a^2} - \frac{y^2}{b^2} = 1$ be $\sqrt{\frac{5}{2}}$ and length of its latus rectum be $6\sqrt{2}$. If

$y = 2x + c$ is a tangent to the hyperbola H , then the value of c^2 is equal to
[28-Jun-2022-Shift-1]

Options:

- A. 18
- B. 20
- C. 24
- D. 32

Answer: B

Solution:

$$1 + \frac{b^2}{a^2} = \frac{5}{2} \Rightarrow \frac{b^2}{a^2} = \frac{3}{2}$$

$$\frac{2b^2}{a} = 6\sqrt{2} \Rightarrow 2 \cdot \frac{3}{2} \cdot a = 6\sqrt{2}$$

$$\Rightarrow a = 2\sqrt{2}, b^2 = 12$$

$$c^2 = a^2 m^2 - b^2 = 8 \cdot 4 - 12 = 20$$

Question 130

Let $a > 0, b > 0$. Let e and l respectively be the eccentricity and length of the latus rectum of the hyperbola $\frac{x^2}{a^2} - \frac{y^2}{b^2} = 1$. Let e' and l' respectively be the eccentricity and length of the latus rectum of its conjugate hyperbola. If $e^2 = \frac{11}{14}l$ and $(e')^2 = \frac{11}{8}l'$, then the value of $77a + 44b$ is equal to :
[28-Jun-2022-Shift-2]

Options:

- A. 100
- B. 110
- C. 120
- D. 130

Answer: D

Solution:

$$H : \frac{x^2}{a^2} - \frac{y^2}{b^2} = 1, \text{ then}$$

$$e^2 = \frac{11}{14}l \quad (l \text{ be the length of LR})$$

$$\Rightarrow a^2 + b^2 = \frac{11}{7}b^2 a \dots (i)$$

$$\text{and } e'^2 = \frac{11}{8}l' \quad (l' \text{ be the length of LR of conjugate hyperbola)}$$

$$\Rightarrow a^2 + b^2 = \frac{11}{4}a^2 b$$

By (i) and (ii)

$$7a = 4b$$

then by (i)

$$\frac{16}{49}b^2 + b^2 = \frac{11}{7}b^2 \cdot \frac{4b}{7}$$

$$\Rightarrow 44b = 65 \quad \text{and} \quad 77a = 65$$

$$\therefore 77a + 44b = 130$$

Question 131

Let $H : \frac{x^2}{a^2} - \frac{y^2}{b^2} = 1, a > 0, b > 0$, be a hyperbola such that the sum of lengths of the transverse and the conjugate axes is $4(2\sqrt{2} + \sqrt{14})$. If the eccentricity H is $\frac{\sqrt{11}}{2}$, then the value of $a^2 + b^2$ is equal to
[29-Jun-2022-Shift-1]

Answer: 88

Solution:

$$2a + 2b = 4(2\sqrt{2} + \sqrt{14}) \dots (1)$$

$$1 + \frac{b^2}{a^2} = \frac{11}{14} \dots (2)$$

$$\Rightarrow \frac{b^2}{a^2} = \frac{7}{4} \dots \dots (3)$$

$$\text{and } a + b = 4\sqrt{2} + 2\sqrt{14}$$

By (3) and (4)

$$\Rightarrow a + \frac{\sqrt{7}}{2}a = 4\sqrt{2} + 2\sqrt{14}$$

$$\Rightarrow \frac{a(2 + \sqrt{7})}{2} = 2\sqrt{2}(2 + \sqrt{7})$$

$$\Rightarrow a = 4\sqrt{2} \Rightarrow a^2 = 32 \text{ and } b^2 = 56$$

$$\Rightarrow a^2 + b^2 = 32 + 56 = 88$$

Question132

Let a circle $C : (x - h)^2 + (y - k)^2 = r^2$, $k > 0$, touch the x -axis at $(1, 0)$. If the line $x + y = 0$ intersects the circle C at P and Q such that the length of the chord PQ is 2, then the value of $h + k + r$ is equal to [24-Jun-2022-Shift-2]

Answer: 7

Solution:

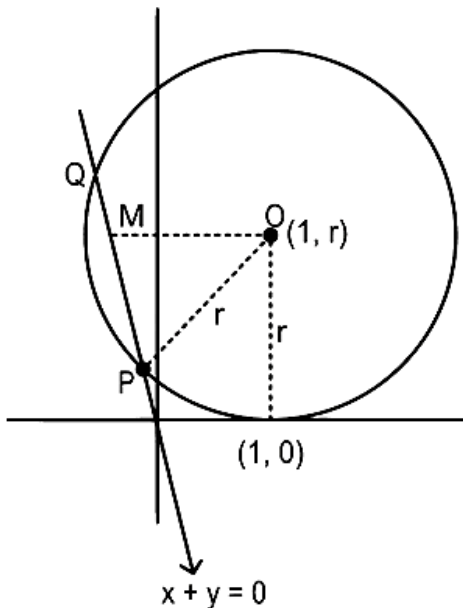

$$x + y = 0$$

$$\text{Here, } OM^2 = OP^2 - PM^2$$

$$\left(\frac{|1+r|}{\sqrt{2}} \right)^2 = r^2 - 1$$

$$\therefore r^2 - 2r - 3 = 0$$

$$\therefore r = 3$$

\therefore Equation of circle is

$$(x - 1)^2 + (y - 3)^2 = 3^2$$

$$\therefore h = 1, k = 3, r = 3$$

$$\therefore h + k + r = 7$$

Question133

Let a circle C touch the lines $L_1 : 4x - 3y + K_1 = 0$ and $L_2 = 4x - 3y + K_2 = 0$, $K_1, K_2 \in \mathbb{R}$. If a line passing through the centre of the circle C intersects L_1 at $(-1, 2)$ and L_2 at $(3, -6)$, then the equation of the circle C is :

[25-Jun-2022-Shift-1]

Options:

A. $(x - 1)^2 + (y - 2)^2 = 4$

B. $(x + 1)^2 + (y - 2)^2 = 4$

C. $(x - 1)^2 + (y + 2)^2 = 16$

D. $(x - 1)^2 + (y - 2)^2 = 16$

Answer: C

Solution:

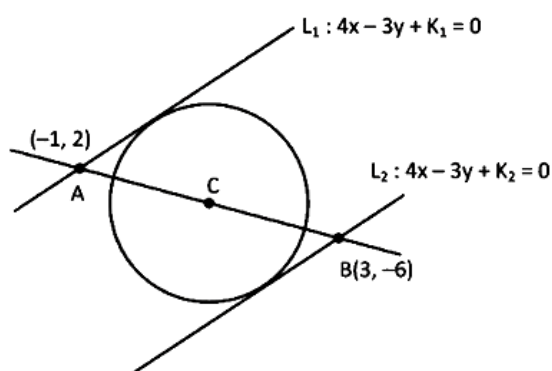

Co-ordinate of centre $C \equiv \left(\frac{3 + (-1)}{2}, \frac{-6 - 2}{2} \right) \equiv (1, -2)$

L_1 is passing through A

$$\Rightarrow -4 - 6 + K_1 = 0$$

$$\Rightarrow K_1 = 10$$

L_2 is passing through B

$$\Rightarrow 12 + 18 + K_2 = 0$$

$$\Rightarrow K_2 = -30$$

Equation of $L_1 : 4x - 3y + 10 = 0$

Equation of $L_2 = 4x - 3y - 30 = 0$

Diameter of circle = $\left| \frac{10 + 30}{\sqrt{4^2 + (-3)^2}} \right| = 8$

$$\Rightarrow \text{Radius} = 4$$

Equation of circle $(x - 1)^2 + (y + 2)^2 = 16$

Question 134

Let the abscissae of the two points P and Q be the roots of $2x^2 - rx + p = 0$ and the ordinates of P and Q be the roots of $x^2 - sx - q = 0$. If the equation of the circle described on PQ as diameter is

$2(x^2 + y^2) - 11x - 14y - 22 = 0$, then $2r + s - 2q + p$ is equal to
[25-Jun-2022-Shift-1]

Answer: 7

Solution:

Let $P(x_1, y_1)$ & $Q(x_2, y_2)$

\therefore Roots of $2x^2 - rx + p = 0$ are x_1, x_2

and roots of $x^2 - sx - q = 0$ are y_1, y_2

\therefore Equation of circle $\equiv (x - x_1)(x - x_2) + (y - y_1)(y - y_2) = 0$

$\Rightarrow x^2 - (x_1 + x_2)x + x_1x_2 + y^2 - (y_1 + y_2)y + y_1y_2 = 0$

$\Rightarrow x^2 - \frac{r}{2}x + \frac{p}{2} + y^2 + sy - q = 0$

$\Rightarrow 2x^2 + 2y^2 - rx + 2sy + p - 2q = 0$

Compare with $2x^2 + 2y^2 - 11x - 14y - 22 = 0$

We get $r = 11, s = 7, p - 2q = -22$

$\Rightarrow 2r + s + p - 2q = 22 + 7 - 22 = 7$

Question 135

A circle touches both the y-axis and the line $x + y = 0$. Then the locus of its center is :
[25-Jun-2022-Shift-2]

Options:

A. $y = \sqrt{2}x$

B. $x = \sqrt{2}y$

C. $y^2 - x^2 = 2xy$

D. $x^2 - y^2 = 2xy$

Answer: D

Solution:

Let the centre be (h, k)

So, $|h| = \left| \frac{h+k}{\sqrt{2}} \right|$

$\Rightarrow 2h^2 = h^2 + k^2 + 2hk$

Locus will be $x^2 - y^2 = 2xy$

Question 136

Let C be a circle passing through the points $A(2, -1)$ and $B(3, 4)$. The line segment AB is not a diameter of C . If r is the radius of C and its centre lies on the circle $(x - 5)^2 + (y - 1)^2 = \frac{13}{2}$, then r^2 is equal to:

[26-Jun-2022-Shift-1]

Options:

A. 32

B. $\frac{65}{2}$

C. $\frac{61}{2}$

D. 30

Answer: B

Solution:

Equation of perpendicular bisector of AB is

$$y - \frac{3}{2} = -\frac{1}{5}\left(x - \frac{5}{2}\right) \Rightarrow x + 5y = 10$$

Solving it with equation of given circle,

$$(x - 5)^2 \left(\frac{10 - x}{5} - 1\right)^2 = \frac{13}{2}$$

$$\Rightarrow (x - 5)^2 \left(1 + \frac{1}{25}\right) = \frac{13}{2}$$

$$\Rightarrow x - 5 = \pm \frac{5}{2} \Rightarrow x = \frac{5}{2} \text{ or } \frac{15}{2}$$

But $x \neq \frac{5}{2}$ because AB is not the diameter.

So, centre will be $\left(\frac{15}{2}, \frac{1}{2}\right)$

$$\text{Now, } r^2 = \left(\frac{15}{2} - 2\right)^2 + \left(\frac{1}{2} + 1\right)^2$$

$$= \frac{65}{2}$$

Question 137

The set of values of k , for which the circle $C : 4x^2 + 4y^2 - 12x + 8y + k = 0$ lies inside the fourth quadrant and the point $\left(1, -\frac{1}{3}\right)$ lies on or inside the circle C , is

[27-Jun-2022-Shift-2]

Options:

A. an empty set

B. $\left(6, \frac{65}{9}\right]$

C. $\left[\frac{80}{9}, 10 \right)$

D. $\left(9, \frac{92}{9} \right]$

Answer: D

Solution:

$$C : 4x^2 + 4y^2 - 12x + 8y + k = 0$$

$\therefore \left(1, -\frac{1}{3} \right)$ lies on or inside the C

$$\text{then } 4 + \frac{4}{9} - 12 - \frac{8}{3} + k \leq 0$$

$$\Rightarrow k \leq \frac{92}{9}$$

Now, circle lies in 4th quadrant centre $\equiv \left(\frac{3}{2}, -1 \right)$

$$\therefore r < 1 \Rightarrow \sqrt{\frac{9}{4} + 1 - \frac{k}{4}} < 1$$

$$\Rightarrow \frac{13}{4} - \frac{k}{4} < 1$$

$$\Rightarrow \frac{k}{4} > \frac{9}{4}$$

$$\Rightarrow k > 9$$

$$\therefore k \in \left(9, \frac{92}{9} \right)$$

Question 138

Let a circle C of radius 5 lie below the x-axis. The line $L_1 : 4x + 3y + 2 = 0$ passes through the centre P of the circle C and intersects the line $L_2 = 3x - 4y - 11 = 0$ at Q. The line L_2 touches C at the point Q. Then the distance of P from the line $5x - 12y + 51 = 0$ is _____

[27-Jun-2022-Shift-2]

Answer: 11

Solution:

$$L_1 : 4x + 3y + 2 = 0$$

$$L_2 : 3x - 4y - 11 = 0$$

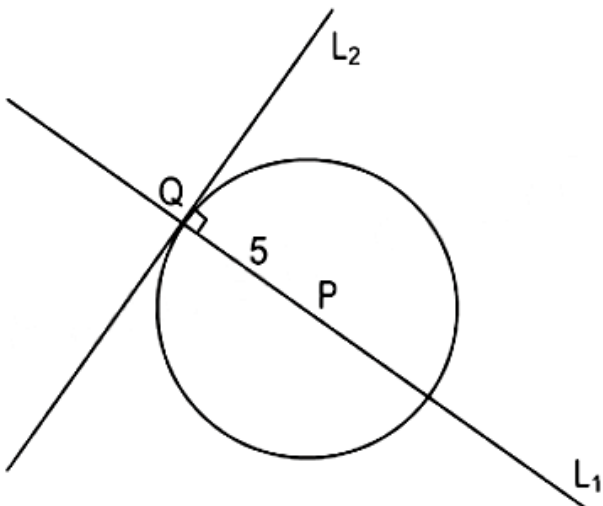

Since circle C touches the line L_2 at Q intersection point Q of L_1 and L_2 , is $(1, -2)$

∴ P lies of L_1

$$\therefore P\left(x, -\frac{1}{3}(2+4x)\right)$$

$$\text{Now, } PQ = 5 \Rightarrow (x-1)^2 + \left(\frac{4x+2}{3}-2\right)^2 = 25$$

$$\Rightarrow (x-1)^2 \left[1 + \frac{16}{9}\right] = 25$$

$$\Rightarrow (x-1)^2 = 9$$

$$\Rightarrow x = 4, -2$$

∴ Circle lies below the x-axis

$$\therefore y = -6$$

$$P(4, -6)$$

Now distance of P from $5x - 12y + 51 = 0$

$$= \left| \frac{20 + 72 + 51}{13} \right| = \frac{143}{13} = 11$$

Question 139

If the tangents drawn at the points $O(0, 0)$ and $P(1 + \sqrt{5}, 2)$ on the circle $x^2 + y^2 - 2x - 4y = 0$ intersect at the point Q, then the area of the triangle OPQ is equal to
[28-Jun-2022-Shift-1]

Options:

A. $\frac{3 + \sqrt{5}}{2}$

B. $\frac{4 + 2\sqrt{5}}{2}$

C. $\frac{5 + 3\sqrt{5}}{2}$

D. $\frac{7 + 3\sqrt{5}}{2}$

Answer: C

Solution:

Solution:

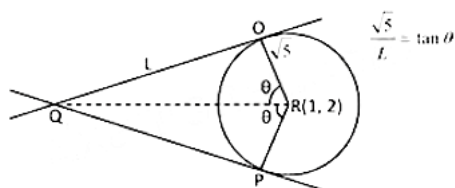

$$\tan 2\theta = 2 \Rightarrow \frac{2 \tan \theta}{1 - \tan^2 \theta} = 2$$

$$\tan \theta = \frac{\sqrt{5} - 1}{2} \quad (\text{as } \theta \text{ is acute})$$

$$\text{Area} = \frac{1}{2} L^2 \sin 2\theta = \frac{1}{2} \cdot \frac{5}{\tan^2 \theta} \cdot 2 \sin \theta \cos \theta$$

$$= \frac{5 \sin \theta \cos \theta}{\sin^2 \theta} \cdot \cos^2 \theta$$

$$= 5 \cot \theta \cdot \cos^2 \theta$$

$$= 5 \cdot \frac{2}{\sqrt{5} - 1} \cdot \frac{1}{1 + \left(\frac{\sqrt{5} - 1}{2}\right)^2}$$

$$= \frac{10}{\sqrt{5} - 1} \cdot \frac{4}{4 + 6 - 2\sqrt{5}}$$

$$= \frac{40}{2\sqrt{5}(\sqrt{5} - 1)^2} = \frac{4\sqrt{5}}{6 - 2\sqrt{5}}$$

$$= \frac{4\sqrt{5}(6+2\sqrt{5})}{16}$$

$$= \frac{\sqrt{5}(3+\sqrt{5})}{2}$$

Question 140

Let the lines $y + 2x = \sqrt{11} + 7\sqrt{7}$ and $2y + x = 2\sqrt{11} + 6\sqrt{7}$ be normal to a circle $C : (x - h)^2 + (y - k)^2 = r^2$. If the line $\sqrt{11}y - 3x = \frac{5\sqrt{77}}{3} + 11$ is tangent to the circle C , then the value of $(5h - 8k)^2 + 5r^2$ is equal to
[28-Jun-2022-Shift-1]

Answer: 816

Solution:

Solution:

Normal are

$$y + 2x = \sqrt{11} + 7\sqrt{7}$$

$$2y + x = 2\sqrt{11} + 6\sqrt{7}$$

Center of the circle is point of intersection of normals i.e.

$$\left(\frac{8\sqrt{7}}{3}, \sqrt{11} + \frac{5\sqrt{7}}{3} \right)$$

$$\text{Tangent is } \sqrt{11}y - 3x = \frac{5\sqrt{77}}{3} + 11$$

Radius will be \perp distance of tangent from center

$$\text{i.e. } 4\sqrt{\frac{7}{5}}$$

$$\text{Now } (5h - 8k)^2 + 5r^2 = 816$$

Question 141

If one of the diameters of the circle $x^2 + y^2 - 2\sqrt{2}x - 6\sqrt{2}y + 14 = 0$ is a chord of the circle $(x - 2\sqrt{2})^2 + (y - 2\sqrt{2})^2 = r^2$, then the value of r^2 is equal to _____
[28-Jun-2022-Shift-2]

Answer: 10

Solution:

$$\text{For } x^2 + y^2 - 2\sqrt{2}x - 6\sqrt{2}y + 14 = 0$$

$$\text{Radius} = \sqrt{(\sqrt{2})^2 + (3\sqrt{2})^2} - 14 = \sqrt{6}$$

$$\Rightarrow \text{Diameter} = 2\sqrt{6}$$

If this diameter is chord to

$$(x - 2\sqrt{2})^2 + (y - 2\sqrt{2})^2 = r^2 \text{ then}$$

$$\Rightarrow r^2 = 6 + \left(\sqrt{(\sqrt{2})^2 + (3\sqrt{2})^2} \right)^2$$

$$\Rightarrow r^2 = 6 + 4 = 10$$

$$\Rightarrow r^2 = 10$$



Question 142

Let the tangent to the circle $C_1 : x^2 + y^2 = 2$ at the point $M(-1, 1)$ intersect the circle $C_2 : (x - 3)^2 + (y - 2)^2 = 5$, at two distinct points A and B. If the tangents to C_2 at the points A and B intersect at N, then the area of the triangle ANB is equal to:
[29-Jun-2022-Shift-1]

Options:

A. $\frac{1}{2}$

B. $\frac{2}{3}$

C. $\frac{1}{6}$

D. $\frac{5}{3}$

Answer: C

Solution:

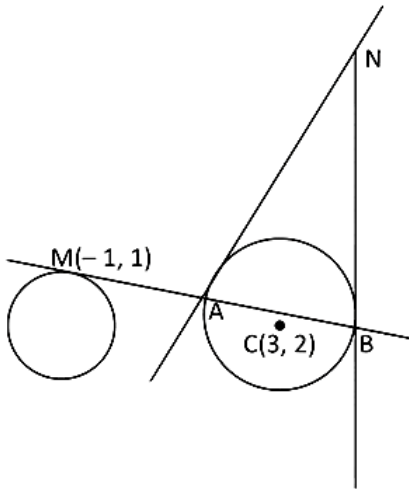

Equation of tangent at point M is

$$T = 0$$

$$\Rightarrow xx_1 + yy_1 = 2$$

$$\Rightarrow -x + y = 2$$

$$\Rightarrow y = x + 2$$

Putting this value to equation of circle C_2 ,

$$(x - 3)^2 + (y - 2)^2 = 5$$

$$\Rightarrow (x - 3)^2 + x^2 = 5$$

$$\Rightarrow x^2 - 6x + 9 + x^2 = 5$$

$$\Rightarrow 2x^2 - 6x + 4 = 0$$

$$\Rightarrow x^2 - 3x + 2 = 0$$

$$\Rightarrow (x - 2)(x - 1) = 0$$

$$\Rightarrow x = 1, 2$$

when $x = 1$, $y = 3$

and when $x = 2$, $y = 4$

\therefore Point A(1, 3) and B(2, 4)

Now, equation of tangent at A(1, 3) on circle $(x - 3)^2 + (y - 2)^2 = 5$ or $x^2 + y^2 - 6x - 4y + 8 = 0$ is

$$T = 0$$

$$xx_1 + yy_1 + g(x + x_1) + f(y + y_1) + C = 0$$

$$\Rightarrow x + 3y - 3(x + 1) - 2(y + 3) + 8 = 0$$

$$\Rightarrow x + 3y - 3x - 3 - 2y - 6 + 8 = 0$$

$$\Rightarrow -2x + y - 1 = 0$$

$$\Rightarrow 2x - y + 1 = 0$$

Similarly tangent at B(2, 4) is



$$2x + 4y - 3(x + 2) - 2(y + 4) + 8 = 0$$

$$\Rightarrow 2x + 4y - 3x - 6 - 2y - 8 + 8 = 0$$

$$\Rightarrow -x + 2y - 6 = 0$$

$$\Rightarrow x - 2y + 6 = 0$$

Solving equation (1) and (2), we get

$$x - 2(2x + 1) + 6 = 0$$

$$\Rightarrow x - 4x - 2 + 6 = 0$$

$$\Rightarrow -3x + 4 = 0$$

$$\Rightarrow x = \frac{4}{3}$$

$$\therefore y = 2 \times \frac{4}{3} + 1 = \frac{11}{3}$$

$$\therefore \text{Point N} = \left(\frac{4}{3}, \frac{11}{3} \right)$$

Now area of the triangle ANB

$$= \frac{1}{2} \begin{vmatrix} x_1 & y_1 & 1 \\ x_2 & y_2 & 1 \\ x_3 & y_3 & 1 \end{vmatrix}$$

$$= \frac{1}{2} \begin{vmatrix} 1 & 3 & 1 \\ 2 & 4 & 1 \\ \frac{4}{3} & \frac{11}{3} & 1 \end{vmatrix}$$

$$= \frac{1}{2} \left[1 \left(4 - \frac{11}{3} \right) - 3 \left(2 - \frac{4}{3} \right) + 1 \left(\frac{22}{3} - \frac{16}{3} \right) \right]$$

$$= \frac{1}{2} \left[\frac{1}{3} - \frac{6}{3} + \frac{6}{3} \right]$$

$$= \frac{1}{6}$$

Question 143

Let a triangle ABC be inscribed in the circle $x^2 - \sqrt{2}(x + y) + y^2 = 0$ such that $\angle BAC = \frac{\pi}{2}$. If the length of side AB is $\sqrt{2}$, then the area of the $\triangle ABC$ is equal to :

[29-Jun-2022-Shift-2]

Options:

A. 1

B. $(\sqrt{6} + \sqrt{3})/2$

C. $(3 + \sqrt{3})/4$

D. $(\sqrt{6} + 2\sqrt{3})/4$

Answer: A

Solution:

For equation of circle $x^2 + y^2 + 2gx + 2fy + c = 0$, center is $(-g, -f)$ and radius $r = \sqrt{g^2 + f^2 - c}$

Given,

equation of circle is

$$x^2 - \sqrt{2}(x + y) + y^2 = 0$$

$$\Rightarrow x^2 + y^2 - \sqrt{2}x - \sqrt{2}y = 0$$

$$\Rightarrow x^2 + y^2 + 2 \left(-\frac{1}{\sqrt{2}} \right) x + 2 \left(-\frac{1}{\sqrt{2}} \right) y = 0$$

$$\therefore g = -\frac{1}{\sqrt{2}} \text{ and } f = -\frac{1}{\sqrt{2}}$$

$$\therefore \text{Center} = (-g, -f) = \left(\frac{1}{\sqrt{2}}, \frac{1}{\sqrt{2}} \right)$$

$$\begin{aligned} \text{And Radius } = r &= \sqrt{\left(-\frac{1}{\sqrt{2}}\right)^2 + \left(-\frac{1}{\sqrt{2}}\right)^2 - 0} \\ &= \sqrt{\frac{1}{2} + \frac{1}{2}} = \sqrt{1} = 1 \end{aligned}$$

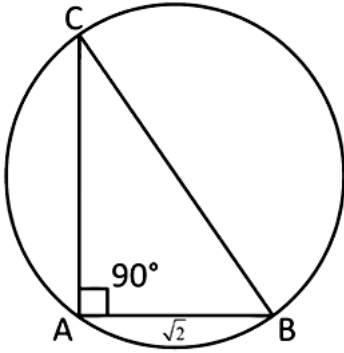

As AB and AC makes an angle 90° then line BC passes through the center of circle and BC is the diameter of the circle.

$$\therefore \text{Length of BC} = 2r = 2 \times 1 = 2$$

$$\therefore AC^2 = BC^2 - AB^2$$

$$= 2^2 - (\sqrt{2})^2$$

$$= 2$$

$$\Rightarrow AC = \sqrt{2}$$

\therefore Area of right angle triangle ABC

$$= \frac{1}{2} \times AC \times AB$$

$$= \frac{1}{2} \times \sqrt{2} \times \sqrt{2}$$

$$= 1 \text{ square unit.}$$

Question 144

A particle is moving in the xy-plane along a curve C passing through the point (3, 3). The tangent to the curve C at the point P meets the x-axis at Q. If the y-axis bisects the segment PQ, then C is a parabola with [24-Jun-2022-Shift-2]

Options:

A. length of latus rectum 3

B. length of latus rectum 6

C. focus $\left(\frac{4}{3}, 0\right)$

D. focus $\left(0, \frac{3}{4}\right)$

Answer: A

Solution:

According to the question (Let $P(x, y)$)

$$2x - y \frac{dx}{dy} = 0$$

$$(\because \text{equation of tangent at } P : y - y = \frac{dy}{dx}(y - x))$$

$$\therefore 2 \frac{dy}{y} = \frac{dx}{x}$$

$$\Rightarrow 2 \ln y = \ln x + \ln c$$

$$\Rightarrow y^2 = cx$$

\because this curve passes through $(3, 3)$

$$\therefore c = 3$$

\therefore required parabola $y^2 = 3x$ and L.R = 3

Question 145

Let P_1 be a parabola with vertex $(3, 2)$ and focus $(4, 4)$ and P_2 be its mirror image with respect to the line $x + 2y = 6$. Then the directrix of P_2 is $x + 2y =$

[24-Jun-2022-Shift-2]

Answer: 10

Solution:

Focus = $(4, 4)$ and vertex = $(3, 2)$

\therefore Point of intersection of directrix with axis of parabola = $A = (2, 0)$

Image of $A(2, 0)$ with respect to line $x + 2y = 6$ is $B(x_2, y_2)$

$$\therefore \frac{x_2 - 2}{1} = \frac{y_2 - 0}{2} = \frac{-2(2 + 0 - 6)}{5}$$

$$\therefore B(x_2, y_2) = \left(\frac{18}{5}, \frac{16}{5} \right)$$

Point B is point of intersection of directrix with axes of parabola P_2 .

$$\therefore x + 2y = \lambda \text{ must have point } \left(\frac{18}{5}, \frac{16}{5} \right)$$

$$\therefore x + 2y = 10$$

Question 146

If $y = m_1x + c_1$ and $y = m_2x + c_2$, $m_1 \neq m_2$ are two common tangents of circle $x^2 + y^2 = 2$ and parabola $y^2 = x$, then the value of $8 | m_1 m_2 |$ is equal to :

[25-Jun-2022-Shift-1]

Options:

A. $3 + 4\sqrt{2}$

B. $-5 + 6\sqrt{2}$

C. $-4 + 3\sqrt{2}$

D. $7 + 6\sqrt{2}$

Answer: C

Solution:

Let tangent to $y^2 = x$ be

$$y = mx + \frac{1}{4m}$$

For it being tangent to circle.

$$\left| \frac{\frac{1}{4m}}{\sqrt{1+m^2}} \right| = \sqrt{2}$$

$$\Rightarrow 32m^4 + 32m^2 - 1 = 0$$

$$\Rightarrow m^2 = \frac{-32 \pm \sqrt{(32)^2 + 4(32)}}{64}$$

$$\Rightarrow 8m_1 m_2 = -4 + 3\sqrt{2}$$

Question 147

Let $x = 2t$, $y = \frac{t^2}{3}$ be a conic. Let S be the focus and B be the point on the axis of the conic such that $SA \perp BA$, where A is any point on the conic. If k is the ordinate of the centroid of the $\triangle SAB$, then $\lim_{t \rightarrow 1} k$ is equal to:

[25-Jun-2022-Shift-1]

Options:

A. $\frac{17}{18}$

B. $\frac{19}{18}$

C. $\frac{11}{18}$

D. $\frac{13}{18}$

Answer: D

Solution:

$$x = 2t, y = \frac{2}{3}$$

$$t \rightarrow 1A \equiv \left(2, \frac{1}{3}\right)$$

$$\text{Given conic is } x^2 = 12y \Rightarrow S \equiv (0, 3)$$

$$\text{Let } B \equiv (0, \beta)$$

$$\text{Given } SA \perp BA$$

$$\left(\frac{1}{3}\right) \left(\frac{\beta - \frac{1}{3}}{-2}\right) = -1$$

$$\Rightarrow \left(\beta - \frac{1}{3}\right) \frac{1}{3} = -2$$

$$\Rightarrow \beta = \frac{1}{3} \left(\frac{-17}{3}\right)$$

$$\text{Ordinate of centroid} = k = \frac{\beta + \frac{1}{3} + 3}{3}$$

$$= \frac{\frac{-17}{9} + \frac{10}{3}}{3} = \frac{13}{18}$$

Question 148

Let the normal at the point on the parabola $y^2 = 6x$ pass through the point $(5, -8)$. If the tangent at P to the parabola intersects its directrix at the point Q, then the ordinate of the point Q is :

[26-Jun-2022-Shift-1]

Options:

A. -3

B. $-\frac{9}{4}$

C. $-\frac{5}{2}$

D. -2

Answer: B

Solution:

Let $P(at^2, 2at)$ where $a = \frac{3}{2}$

T : $yt = x + at^2$ So point Q is $(-a, at - \frac{a}{t})$

N : $y = -tx + 2at + at^3$ passes through $(5, -8)$

$$-8 = -5t + 3t + \frac{3}{2}t^3$$

$$\Rightarrow 3t^3 - 4t + 16 = 0$$

$$\Rightarrow (t+2)(3t^2 - 6t + 8) = 0$$

$$\Rightarrow t = 2$$

So ordinate of point Q is $-\frac{9}{4}$.

Question 149

A circle of radius 2 unit passes through the vertex and the focus of the parabola $y^2 = 2x$ and touches the parabola $y = (x - \frac{1}{4})^2 + \alpha$, where $\alpha > 0$. Then $(4\alpha - 8)^2$ is equal to ____
[27-Jun-2022-Shift-1]

Answer: 63

Solution:

Solution:

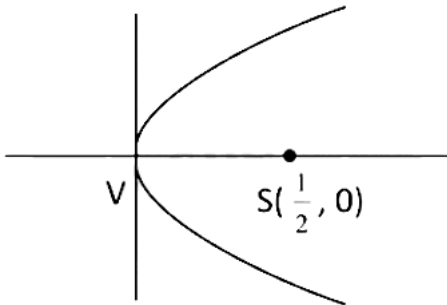

Let the equation of circle be

$$x(x - \frac{1}{2}) + y^2 + \lambda y = 0$$

$$\Rightarrow x^2 + y^2 - \frac{1}{2}x + \lambda y = 0$$

$$\text{Radius} = \sqrt{\frac{1}{16} + \frac{\lambda^2}{4}} = 2$$

$$\Rightarrow \lambda^2 = \frac{63}{4}$$

$$\Rightarrow (x - \frac{1}{4})^2 + (y + \frac{\lambda}{2})^2 = 4$$

\therefore This circle and parabola $y - \alpha = (x - \frac{1}{4})^2$ touch each other, so

$$\alpha = -\frac{\lambda}{2} + 2$$

$$\Rightarrow \alpha - 2 = -\frac{\lambda}{2}$$

$$\Rightarrow (\alpha - 2)^2 = \frac{\lambda^2}{4} = \frac{63}{16}$$

$$\Rightarrow (4\alpha - 8)^2 = 63$$



Question150

If the equation of the parabola, whose vertex is at (5, 4) and the directrix is $3x + y - 29 = 0$, is $x^2 + ay^2 + bxy + cx + d y + k = 0$, then $a + b + c + d + k$ is equal to
[27-Jun-2022-Shift-2]

Options:

- A. 575
- B. -575
- C. 576
- D. -576

Answer: D

Solution:

Given vertex is (5, 4) and directrix $3x + y - 29 = 0$

Let foot of perpendicular of (5, 4) on directrix is (x_1, y_1)

$$\frac{x_1 - 5}{3} = \frac{y_1 - 4}{1} = \frac{-(-10)}{10}$$

$$\therefore (x_1, y_1) \equiv (8, 5)$$

So, focus of parabola will be $S = (2, 3)$

Let $P(x, y)$ be any point on parabola, then

$$(x - 2)^2 + (y - 3)^2 = \frac{(3x + y - 29)^2}{10}$$

$$\Rightarrow 10(x^2 + y^2 - 4x - 6y + 13) = 9x^2 + y^2 + 841 + 6xy - 58y - 174x$$

$$\Rightarrow x^2 + 9y^2 - 6xy + 134x - 2y - 711 = 0$$

and given parabola

$$x^2 + ay^2 + bxy + cx + d y + k = 0$$

$$\therefore a = 9, b = -6, c = 134, d = -2, k = -711$$

$$\therefore a + b + c + d + k = -576$$

Question151

If vertex of a parabola is (2, -1) and the equation of its directrix is $4x - 3y = 21$, then the length of its latus rectum is :
[28-Jun-2022-Shift-2]

Options:

- A. 2
- B. 8
- C. 12
- D. 16

Answer: B

Solution:

Vertex of Parabola : (2, -1)

and directrix : $4x - 3y = 21$

Distance of vertex from the directrix

$$a = \left| \frac{8+3-21}{\sqrt{25}} \right| = 2$$

$$\therefore \text{length of latus rectum} = 4a = 8$$

Question 152

Let $P : y^2 = 4ax, a > 0$ be a parabola with focus S . Let the tangents to the parabola P make an angle of $\frac{\pi}{4}$ with the line $y = 3x + 5$ touch the parabola P at A and B . Then the value of a for which A, B and S are collinear is
[29-Jun-2022-Shift-2]

Options:

- A. 8 only
- B. 2 only
- C. $\frac{1}{4}$ only
- D. any $a > 0$

Answer: D

Solution:

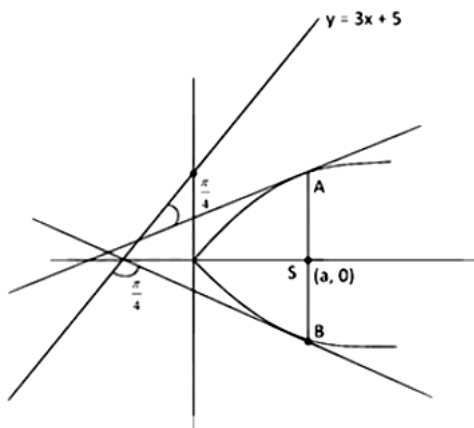

$$\tan \frac{\pi}{4} = \left| \frac{m-3}{1+3m} \right|$$

$$\Rightarrow \frac{m-3}{1+3m} = \pm 1$$

$$\Rightarrow \frac{m-3}{1+3m} = +1 \text{ and } \frac{m-3}{1+3m} = -1$$

$$\Rightarrow m-3 = 1+3m \text{ and } m-3 = -1-3m$$

$$\Rightarrow 2m = -4 \text{ and } 4m = 2$$

$$m = -2 \text{ and } m = \frac{1}{2}$$

We know, Equation of tangent to the parabola $y^2 = 4m$ is $y = mx + \frac{a}{m}$ and point of contact is $\left(\frac{a}{m^2}, \frac{2a}{m} \right)$

\therefore Equation of tangent

$$y = -2x - \frac{a}{2}$$

$$\text{and } y = \frac{x}{2} + 2a$$

\therefore Point of contact A and B are

$$A \left(\frac{a}{(-2)^2}, \frac{2a}{-2} \right) = A \left(\frac{a}{4}, -a \right)$$

$$B \left(\frac{a}{\left(\frac{1}{2}\right)^2}, \frac{2a}{\left(\frac{1}{2}\right)} \right) = B(4a, 4a)$$

As points A, B and S are collinear so area of triangle formed by those 3 points are zero.

$$\text{Area of } \triangle ABS = \frac{1}{2} \begin{vmatrix} \frac{a}{4} & -a & 1 \\ 4a & 4a & 1 \\ a & 0 & 1 \end{vmatrix}$$

$$= \frac{a}{4}(4a - 0) + a(4a - a) + 1(0 - 4a^2)$$

$$= a^2 + 3a^2 - 4a^2 = 0$$

∴ Area of triangle is independent of value of a.

So, for all value of $a > 0$ (already given a must be greater than 0) point A, B and S will be collinear.

Question 153

Let the maximum area of the triangle that can be inscribed in the ellipse $\frac{x^2}{a^2} + \frac{y^2}{4} = 1$, $a > 2$, having one of its vertices at one end of the major axis of the ellipse and one of its sides parallel to the y-axis, be $6\sqrt{3}$. Then the eccentricity of the ellipse is :
[24-Jun-2022-Shift-2]

Options:

A. $\frac{\sqrt{3}}{2}$

B. $\frac{1}{2}$

C. $\frac{1}{\sqrt{2}}$

D. $\frac{\sqrt{3}}{4}$

Answer: A

Solution:

Given ellipse $\frac{x^2}{a^2} + \frac{y^2}{4} = 1$, $a > 2$

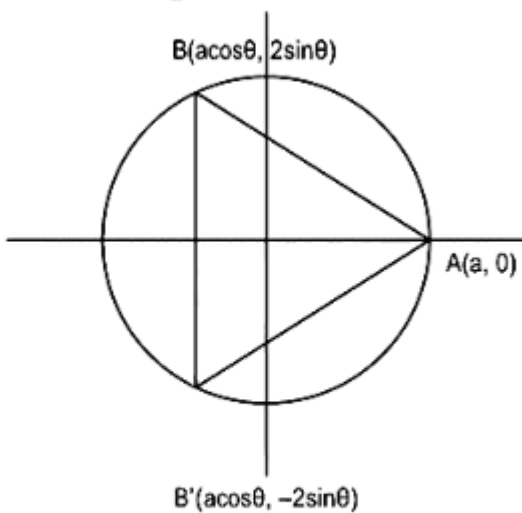

∴ Let $A(\theta)$ be the area of $\triangle ABB'$

$$\text{Then } A(\theta) = \frac{1}{2} \cdot 4 \sin \theta (a + a \cos \theta)$$



$$A'(\theta) = a(2 \cos \theta + 2 \cos^2 \theta)$$

$$\text{For maxima } A'(\theta) = 0$$

$$\Rightarrow \cos \theta = 1, \cos \theta = \frac{1}{2}$$

$$\text{But for maximum area } \cos \theta = \frac{1}{2}$$

$$\therefore A(\theta) = 6\sqrt{3}$$

$$\Rightarrow 2 \frac{\sqrt{3}}{2} \left(a + \frac{a}{2} \right) = 6\sqrt{3}$$

$$\Rightarrow a = 4$$

$$\therefore e = \sqrt{1 - \frac{b^2}{a^2}} = \sqrt{1 - \frac{4}{16}} = \frac{\sqrt{3}}{2}$$

Question 154

The line $y = x + 1$ meets the ellipse $\frac{x^2}{4} + \frac{y^2}{2} = 1$ at two points P and Q. If r is the radius of the circle with PQ as diameter then $(3r)^2$ is equal to:
[25-Jun-2022-Shift-2]

Options:

- A. 20
- B. 12
- C. 11
- D. 8

Answer: A

Solution:

Let point $(a, a + 1)$ as the point of intersection of line and ellipse.

$$\text{So, } \frac{a^2}{4} + \frac{(a+1)^2}{2} = 1 \Rightarrow a^2 + 2(a^2 + 2a + 1) = 4$$

$$\Rightarrow 3a^2 + 4a - 2 = 0$$

If roots of this equation are α and β .

So, $P(\alpha, \alpha + 1)$ and $Q(\beta, \beta + 1)$

$$\begin{aligned}
 PQ &= 4r^2 = (\alpha - \beta)^2 + (\alpha - \beta)^2 \\
 \Rightarrow 9r^2 &= \frac{9}{4}(2(\alpha - \beta)^2) \\
 &= \frac{9}{2}[(\alpha + \beta)^2 - 4\alpha\beta] \\
 &= \frac{9}{2}\left[\left(-\frac{4}{3}\right)^2 + \frac{8}{3}\right] \\
 &= \frac{1}{2}[16 + 24] = 20
 \end{aligned}$$

Question 155

Let the common tangents to the curves $4(x^2 + y^2) = 9$ and $y^2 = 4x$ intersect at the point Q. Let an ellipse, centered at the origin O, has lengths of semi-minor and semi-major axes equal to OQ and 6, respectively. If e and l respectively denote the eccentricity and the length of the latus rectum of this ellipse, then $\frac{l}{e^2}$ is equal

to _____
[26-Jun-2022-Shift-1]

Answer: 4

Solution:

Let $y = mx + c$ is the common tangent

$$\text{So } c = \frac{1}{m} = \pm \frac{3}{2} \sqrt{1+m^2} \Rightarrow m^2 = \frac{1}{3}$$

So equation of common tangents will be $y = \pm \frac{1}{\sqrt{3}}x \pm \sqrt{3}$, which intersects at $Q(-3, 0)$

Major axis and minor axis of ellipse are 12 and 6.

So eccentricity

$$e^2 = 1 - \frac{1}{4} = \frac{3}{4} \text{ and length of latus rectum } = \frac{2b^2}{a} = 3$$

$$\text{Hence, } \frac{l}{e^2} = \frac{3}{3/4} = 4$$

Question 156

If m is the slope of a common tangent to the curves $\frac{x^2}{16} + \frac{y^2}{9} = 1$ and $x^2 + y^2 = 12$, then $12m^2$ is equal to :

[26-Jun-2022-Shift-2]

Options:

- A. 6
- B. 9
- C. 10
- D. 12

Answer: B



Solution:

$$C_1: \frac{x^2}{16} + \frac{y^2}{9} = 1 \text{ and } C_2: x^2 + y^2 = 12$$

Let $y = mx \pm \sqrt{16m^2 + 9}$ be any tangent to C_1 and if this is also tangent to C_2 then

$$\left| \frac{\sqrt{16m^2 + 9}}{\sqrt{m^2 + 1}} \right| = \sqrt{12}$$

$$\Rightarrow 16m^2 + 9 = 12m^2 + 12$$

$$\Rightarrow 4m^2 = 3 \Rightarrow 12m^2 = 9$$

Question157

The locus of the mid point of the line segment joining the point (4, 3) and the points on the ellipse $x^2 + 2y^2 = 4$ is an ellipse with eccentricity :
[26-Jun-2022-Shift-2]

Options:

A. $\frac{\sqrt{3}}{2}$

B. $\frac{1}{2\sqrt{2}}$

C. $\frac{1}{\sqrt{2}}$

D. $\frac{1}{2}$

Answer: C

Solution:

Let $P(2 \cos \theta, \sqrt{2} \sin \theta)$ be any point on ellipse $\frac{x^2}{4} + \frac{y^2}{2} = 1$ and $Q(4, 3)$ and let (h, k) be the mid point of PQ then $h = \frac{2 \cos \theta + 4}{2}$, $k = \frac{\sqrt{2} \sin \theta + 3}{2}$

$$\therefore \cos \theta = h - 2, \sin \theta = \frac{2k - 3}{\sqrt{2}}$$

$$\therefore (h - 2)^2 + \left(\frac{2k - 3}{\sqrt{2}} \right)^2 = 1$$

$$\Rightarrow \frac{(x - 2)^2}{1} + \frac{\left(y - \frac{3}{2} \right)^2}{\frac{1}{2}} = 1$$

$$\therefore e = \sqrt{1 - \frac{1}{2}} = \frac{1}{\sqrt{2}}$$

Question158

Let the eccentricity of an ellipse $\frac{x^2}{a^2} + \frac{y^2}{b^2} = 1$, $a > b$, be $\frac{1}{4}$. If this ellipse passes through the point

$\left(-4\sqrt{\frac{2}{5}}, 3\right)$, then $a^2 + b^2$ is equal to :

[27-Jun-2022-Shift-1]

Options:

- A. 29
- B. 31
- C. 32
- D. 34

Answer: B

Solution:

Solution:

$$\frac{x^2}{a^2} + \frac{y^2}{b^2} = 1$$
$$\Rightarrow \frac{\left(-4\sqrt{\frac{2}{5}}\right)^2}{a^2} + \frac{32}{b^2} = 1$$

$$\Rightarrow \frac{32}{5a^2} + \frac{9}{b^2} = 1 \dots (i)$$

$$a^2(1 - e^2) = b^2$$

$$a^2\left(1 - \frac{1}{16}\right) = b^2$$

$$15a^2 = 16b^2 \Rightarrow a^2 = \frac{16b^2}{15}$$

From (i)

$$\frac{6}{b^2} + \frac{9}{b^2} = 1 \Rightarrow b^2 = 15 \text{ \& } a^2 = 16$$

$$a^2 + b^2 = 15 + 16 = 31$$

Question 159

Let PQ be a focal chord of the parabola $y^2 = 4x$ such that it subtends an angle of $\frac{\pi}{2}$ at the point (3, 0). Let the line segment PQ be also a focal chord of the ellipse E : $\frac{x^2}{a^2} + \frac{y^2}{b^2} = 1$, $a^2 > b^2$. If e is the eccentricity of the ellipse E, then the value of $\frac{1}{e^2}$ is equal to:

[29-Jun-2022-Shift-1]

Options:

- A. $1 + \sqrt{2}$
- B. $3 + 2\sqrt{2}$
- C. $1 + 2\sqrt{3}$
- D. $4 + 5\sqrt{3}$

Answer: B

Solution:

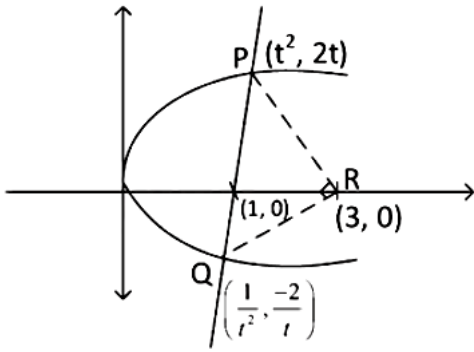

As $\angle PRQ = \frac{\pi}{2}$

$$\left(\frac{\frac{2}{t}}{3 - \frac{1}{t^2}} \right) \cdot \left(\frac{-2t}{3 - t^2} \right) = -1$$

$$\Rightarrow t = \pm 1$$

$$\therefore P = (1, 2) \text{ \& } Q(1, -2)$$

\therefore for ellipse $\frac{1}{a^2} + \frac{4}{b^2} = 1$ and $ae = 1$

$$\Rightarrow \frac{1}{a^2} + \frac{4}{a^2(1-e^2)} = 1$$

$$\Rightarrow 1 + \frac{4}{(1-e^2)} = \frac{1}{e^2}$$

$$\Rightarrow (5-e^2)e^2 = 1 - e^2$$

$$\Rightarrow e^4 - 6e^2 + 1 = 0$$

$$\Rightarrow e^2 = \frac{1}{3-2\sqrt{2}} \Rightarrow \frac{1}{e^2} = 3+2\sqrt{2}$$

Question 160

The odd natural number a , such that the area of the region bounded by $y = 1$, $y = 3$, $x = 0$, $x = y^a$ is $\frac{364}{3}$, is equal to:

[26-Jul-2022-Shift-1]

Options:

- A. 3
- B. 5
- C. 7
- D. 9

Answer: B

Solution:

a is an odd natural number and

$$\left| \int_1^3 y^a dy \right| = \frac{364}{3}$$

$$\Rightarrow \left| \frac{1}{a+1} (y^{a+1})_1^3 \right| = \frac{364}{3}$$

$$\Rightarrow \frac{3^{a+1} - 1}{a+1} = \pm \frac{364}{3}$$

Solving with (-) sign,

$$\frac{3^{a+1} - 1}{a+1} = \frac{364}{3} \Rightarrow (a = 5)$$

Solving with (+) sign,

$$\frac{3^{a+1} - 1}{a + 1} = \frac{-364}{3}, \text{ No a exist}$$

$$\therefore (a = 5)$$

Question 161

The area bounded by the curves $y = |x^2 - 1|$ and $y = 1$ is
[26-Jul-2022-Shift-2]

Options:

A. $\frac{2}{3}(\sqrt{2} + 1)$

B. $\frac{4}{3}(\sqrt{2} - 1)$

C. $2(\sqrt{2} - 1)$

D. $\frac{8}{3}(\sqrt{2} - 1)$

Answer: D

Solution:

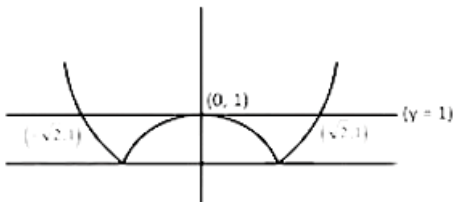

$$\text{Area} = 2 \int_0^{\sqrt{2}} (1 - |x^2 - 1|) dx$$

$$2 \left[\int_0^1 (1 - (1 - x^2)) dx + \int_1^{\sqrt{2}} (2 - x^2) dx \right]$$

$$= 2 \left[\left[\frac{x^3}{3} \right]_0^1 + \left[2x - \frac{x^3}{3} \right]_1^{\sqrt{2}} \right]$$

$$= 2 \left(\frac{4\sqrt{2} - 4}{3} \right) = \frac{8}{3}(\sqrt{2} - 1)$$

Question 162

The area of the smaller region enclosed by the curves $y^2 = 8x + 4$ and $x^2 + y^2 + 4\sqrt{3}x - 4 = 0$ is equal to
[27-Jul-2022-Shift-1]

Options:

A. $\frac{1}{3}(2 - 12\sqrt{3} + 8\pi)$

B. $\frac{1}{3}(2 - 12\sqrt{3} + 6\pi)$

C. $\frac{1}{3}(4 - 12\sqrt{3} + 8\pi)$

D. $\frac{1}{3}(4 - 12\sqrt{3} + 6\pi)$

Answer: C

Solution:

$$\cos \theta = \frac{2\sqrt{3}}{4} = \frac{\sqrt{3}}{2} \Rightarrow \theta = 30^\circ$$

Area of the required region

$$= \frac{2}{3} \left(4 \times \frac{1}{2} \right) + 4^2 \times \frac{\pi}{6} - \frac{1}{2} \times 4 \times 2\sqrt{3}$$

$$= \frac{4}{3} + \frac{8\pi}{3} - 4\sqrt{3} = \frac{1}{3} \{ 4 - 12\sqrt{3} + 8\pi \}$$

Question 163

The area of the region enclosed by $y \leq 4x^2$, $x^2 \leq 9y$ and $y \leq 4$, is equal to :
[27-Jul-2022-Shift-2]

Options:

- A. $\frac{40}{3}$
- B. $\frac{56}{3}$
- C. $\frac{112}{3}$
- D. $\frac{80}{3}$

Answer: D

Solution:

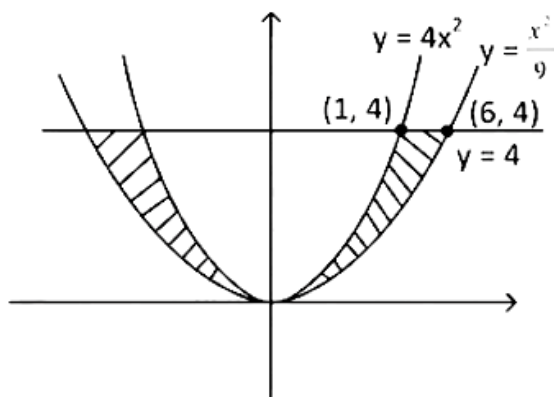

$$y \leq 4x^2, x^2 \leq 9y, y \leq 4$$

So, required area

$$A = 2 \int_0^4 \left(3\sqrt{y} - \frac{1}{2}\sqrt{y} \right) dy$$

$$= 2 \cdot \frac{5}{2} \left[\frac{2}{3}y^{\frac{3}{2}} \right]_0^4$$

$$= \frac{10}{3} [4^{3/2} - 0] = \frac{80}{3}$$

Question 164

Consider a curve $y = y(x)$ in the first quadrant as shown in the figure. Let the area A_1 is twice the area A_2 . Then the normal to the curve perpendicular to the line $2x - 12y = 15$ does NOT pass through the point.

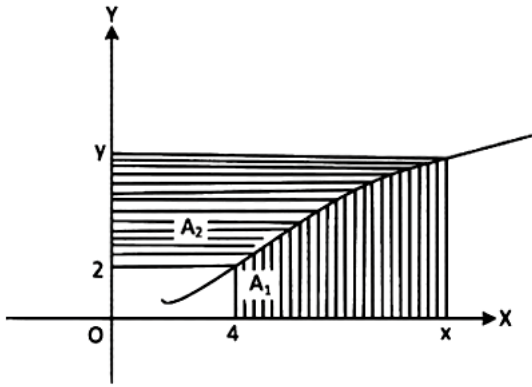

[27-Jul-2022-Shift-2]

Options:

- A. (6, 21)
- B. (8, 9)
- C. (10, -4)
- D. (12, -15)

Answer: C

Solution:

$$A_1 + A_2 = xy - 8 \text{ \& } A_1 = 2A_2$$

$$A_1 + \frac{A_1}{2} = xy - 8$$

$$A_1 = \frac{2}{3}(xy - 8)$$

$$\int_4^x f(x) dx = \frac{2}{3}(xf(x) - 8)$$

Differentiate w.r.t. x

$$f(x) = \frac{2}{3}\{xf'(x) + f(x)\}$$

$$\frac{2}{3}xf'(x) = \frac{1}{3}f(x)$$

$$2 \int \frac{f'(x)}{f(x)} dx = \int \frac{dx}{x}$$

$$2 \ln f(x) = \ln x + \ln c$$

$$f^2(x) = cx$$

Which passes through (4, 2)

$$4 = c \times 4 \Rightarrow c = 1$$

Equation of required curve

$$y^2 = x$$

Equation of normal having slope (-6) is

$$y = -6x - 2\left(\frac{1}{4}\right)(-6) - \frac{1}{4}(-6)^3$$

$$y = -6x + 57$$

Which does not pass through (10, -4)

Question 165

The area enclosed by the curves $y = \log_e(x + e^2)$, $x = \log_e\left(\frac{2}{y}\right)$ and $x = \log_e 2$, above the line $y = 1$ is:

[28-Jul-2022-Shift-2]

Options:

- A. $2 + e - \log_e 2$

B. $1 + e - \log_e 2$

C. $e - \log_e 2$

D. $1 + \log_e 2$

Answer: B

Solution:

Solution:

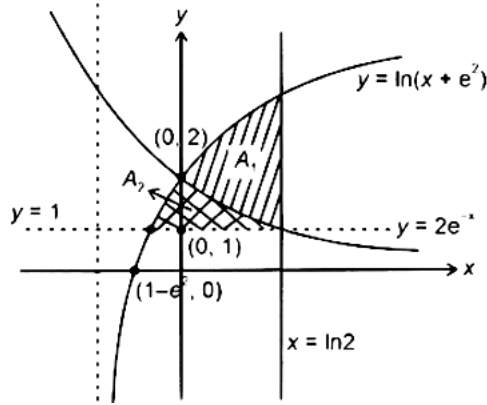

According to NTA, the required region A_2 which is shaded in crossed lines and comes out to be

$$A_2 = \int_1^2 \left(\ln \frac{2}{y} - e^y + e^2 \right) dy = 1 + e - \ln 2$$

But according to us the required region A_1 comes out to be shaded in parallel lines, which can be obtained as

$$\begin{aligned} A_1 &= \int_0^{\ln 2} (\ln(x + e^2) - 2e^{-x}) dx \\ &= \{(x + e^2) \ln(x + e^2) - x + 2e^{-x}\} \Big|_0^{\ln 2} \\ &= (\ln 2 + e^2) \ln(\ln 2 + e^2) - \ln 2 + 1 - 2e^2 - 2 \\ &= (\ln 2 + e^2) \ln(\ln 2 + e^2) - \ln 2 - 2e^2 - 1 \end{aligned}$$

Not given in any option.

The region asked in the question is bounded by three curves

$$y = \ln(x + e^2)$$

$$x = \ln\left(\frac{2}{y}\right)$$

$$x = \ln 2$$

There is only one region which satisfies above requirement and which also lies above line $y = 1$

Line $y = 1$ may or may not be the boundary of the region.

Question 166

The area of the region $\{(x, y) : |x - 1| \leq y \leq \sqrt{5 - x^2}\}$ is equal to
[29-Jul-2022-Shift-1]

Options:

A. $\frac{5}{2} \sin^{-1}\left(\frac{3}{5}\right) - \frac{1}{2}$

B. $\frac{5\pi}{4} - \frac{3}{2}$

C. $\frac{3\pi}{4} + \frac{3}{2}$

D. $\frac{5\pi}{4} - \frac{1}{2}$

Answer: D

Solution:

$$A = 2 \left(\frac{x}{2} \sqrt{5-x^2} + \frac{5}{2} \sin^{-1} \frac{x}{\sqrt{5}} \right) - 2x \Big|_0^1 + \frac{x}{2} \sqrt{5-x^2} + \frac{5}{2} \sin^{-1} \frac{x}{\sqrt{5}} - \frac{x^2}{2} + x \Big|_1^2$$
$$= \left(\frac{5\pi}{4} - \frac{1}{2} \right) \text{ sq. units}$$

Question 167

Let the equation of two diameters of a circle $x^2 + y^2 - 2x + 2fy + 1 = 0$ be $2px - y = 1$ and $2x + py = 4p$. Then the slope $m \in (0, \infty)$ of the tangent to the hyperbola $3x^2 - y^2 = 3$ passing through the centre of the circle is equal to
[25-Jul-2022-Shift-1]

Answer: 2

Solution:

$$2p + f - 1 = 0 \dots (1)$$

$$2 - pf - 4p = 0 \dots (2)$$

$$2 = p(f + 4)$$

$$p = \frac{2}{f + 4}$$

$$2p = 1 - f$$

$$\frac{4}{f + 4} = 1 - f$$

$$f^2 + 3f = 0$$

$$f = 0 \text{ or } -3$$

$$\text{Hyperbola } 3x^2 - y^2 = 3, x^2 - \frac{y^2}{3} = 1$$

$$y = mx \pm \sqrt{m^2 - 3}$$

It passes (1, 0)

$$0 = m \pm \sqrt{m^2 - 3}$$

m tends ∞

It passes (1, 3)

$$3 = m \pm \sqrt{m^2 - 3}$$

$$(3 - m)^2 = m^2 - 3$$

$$m = 2$$

Question 168

Let the foci of the ellipse $\frac{x^2}{16} + \frac{y^2}{7} = 1$ and the hyperbola $\frac{x^2}{144} - \frac{y^2}{\alpha} = \frac{1}{25}$ coincide. Then the length of the latus rectum of the hyperbola is:
[25-Jul-2022-Shift-2]

Options:

A. $\frac{32}{9}$

B. $\frac{18}{5}$

C. $\frac{27}{4}$

D. $\frac{27}{10}$

Answer: D

Solution:

Solution:

Ellipse: $\frac{x^2}{16} + \frac{y^2}{7} = 1$

Eccentricity = $\sqrt{1 - \frac{7}{16}} = \frac{3}{4}$

Foci $\equiv (\pm ae, 0) \equiv (\pm 3, 0)$

Hyperbola: $\frac{x^2}{\left(\frac{144}{25}\right)} - \frac{y^2}{\left(\frac{\alpha}{25}\right)} = 1$

Eccentricity = $\sqrt{1 + \frac{\alpha}{144}} = \frac{1}{12}\sqrt{144 + \alpha}$

Foci $\equiv (\pm ae, 0) \equiv \left(\pm \frac{12}{5} \cdot \frac{1}{12}\sqrt{144 + \alpha}, 0\right)$

If foci coincide then $3 = \frac{1}{5}\sqrt{144 + \alpha} \Rightarrow \alpha = 81$

Hence, hyperbola is $\frac{x^2}{\left(\frac{12}{5}\right)^2} - \frac{y^2}{\left(\frac{9}{5}\right)^2} = 1$

Length of latus rectum = $2 \cdot \frac{\frac{81}{25}}{\frac{12}{5}} = \frac{27}{10}$

Question 169

Let the tangent drawn to the parabola $y^2 = 24x$ at the point (α, β) is perpendicular to the line $2x + 2y = 5$. Then the normal to the hyperbola $\frac{x^2}{\alpha^2} - \frac{y^2}{\beta^2} = 1$ at the point $(\alpha + 4, \beta + 4)$ does NOT pass through the point:
[26-Jul-2022-Shift-1]

Options:

A. (25, 10)

B. (20, 12)

C. (30, 8)

D. (15, 13)

Answer: D

Solution:

Any tangent to $y^2 = 24x$ at (α, β)

$\beta y = 12(x + \alpha)$

Slope = $\frac{12}{\beta}$ and perpendicular to $2x + 2y = 5$

$\Rightarrow \frac{12}{\beta} = 1 \Rightarrow \beta = 12, \alpha = 6$

Hence hyperbola is $\frac{x^2}{36} - \frac{y^2}{144} = 1$ and normal is drawn at $(10, 16)$

Equation of normal $\frac{36 \cdot x}{10} + \frac{144 \cdot y}{16} = 36 + 144$

$\Rightarrow \frac{x}{50} + \frac{y}{20} = 1$

This does not pass through $(15, 13)$ out of given option.

Question170

If the line $x - 1 = 0$ is a directrix of the hyperbola $kx^2 - y^2 = 6$, then the hyperbola passes through the point
[26-Jul-2022-Shift-2]

Options:

- A. $(-2\sqrt{5}, 6)$
- B. $(-\sqrt{5}, 3)$
- C. $(\sqrt{5}, -2)$
- D. $(2\sqrt{5}, 3\sqrt{6})$

Answer: C

Solution:

$$\text{Given hyperbola : } \frac{x^2}{6/k} - \frac{y^2}{6} = 1$$

$$\text{Eccentricity } = e = \sqrt{1 + \frac{6}{6/k}} = \sqrt{1+k}$$

$$\text{Directrices : } x = \pm \frac{a}{e} \Rightarrow x = \pm \frac{\sqrt{6}}{\sqrt{k}\sqrt{k+1}}$$

$$\text{As given : } \frac{\sqrt{6}}{\sqrt{k}\sqrt{k+1}} = 1$$

$$\Rightarrow k = 2$$

$$\text{Here hyperbola is } \frac{x^2}{3} - \frac{y^2}{6} = 1$$

Checking the option gives $(\sqrt{5}, -2)$ satisfies it.

Question171

An ellipse $E : \frac{x^2}{a^2} + \frac{y^2}{b^2} = 1$ passes through the vertices of the hyperbola $H : \frac{x^2}{49} - \frac{y^2}{64} = -1$. Let the major and minor axes of the ellipse E coincide with the transverse and conjugate axes of the hyperbola H , respectively. Let the product of the eccentricities of E and H be $\frac{1}{2}$. If l is the length of the latus rectum of the ellipse E , then the value of $113l$ is equal to _____.
[27-Jul-2022-Shift-1]

Answer: 1552

Solution:

$$\text{Vertices of hyperbola } = (0, \pm 8)$$

As ellipse pass through it i.e.,

$$0 + \frac{64}{b^2} = 1 \Rightarrow b^2 = 64 \dots (1)$$

As major axis of ellipse coincide with transverse axis of hyperbola we have $b > a$ i.e.

$$e_E = \sqrt{1 - \frac{a^2}{64}} = \frac{\sqrt{64 - a^2}}{8}$$

$$\text{and } e_H = \sqrt{1 + \frac{49}{64}} = \frac{\sqrt{113}}{8}$$

$$\therefore e_E \cdot e_H = \frac{1}{2} = \frac{\sqrt{64-a^2}\sqrt{113}}{64}$$

$$\Rightarrow (64-a^2)(113) = 32^2$$

$$\Rightarrow a^2 = 64 - \frac{1024}{113}$$

$$\text{L.R of ellipse} = \frac{2a^2}{b} = \frac{2}{8} \left(\frac{113 \times 64 - 1024}{113} \right) = 1 = \frac{1552}{113}$$

$$\therefore 1131 = 1552$$

Question 172

A common tangent T to the curves $C_1 : \frac{x^2}{4} + \frac{y^2}{9} = 1$ and $C_2 : \frac{x^2}{42} - \frac{y^2}{143} = 1$ does not pass through the fourth quadrant. If T touches C_1 at (x_1, y_1) and C_2 at (x_2, y_2) , then $|2x_1 + x_2|$ is equal to _____.

[27-Jul-2022-Shift-2]

Answer: 20

Solution:

Equation of tangent to ellipse $\frac{x^2}{4} + \frac{y^2}{9} = 1$ and given slope m is : $y = mx + \sqrt{4m^2 + 9} \dots (i)$

For slope m equation of tangent to hyperbola is :

$$y = mx + \sqrt{42m^2 - 143}$$

Tangents from (i) and (ii) are identical then

$$4m^2 + 9 = 42m^2 - 143$$

$$\therefore m = \pm 2 \text{ (} +2 \text{ is not acceptable)}$$

$$\therefore m = -2.$$

$$\text{Hence, } x_1 = \frac{8}{5} \text{ and } x_2 = \frac{84}{5}$$

$$\therefore |2x_1 + x_2| = \left| \frac{16}{5} + \frac{84}{5} \right| = 20$$

Question 173

For the hyperbola H : $x^2 - y^2 = 1$ and the ellipse E : $\frac{x^2}{a^2} + \frac{y^2}{b^2} = 1$, $a > b > 0$, let the

(1) eccentricity of E be reciprocal of the eccentricity of H, and

(2) the line $y = \sqrt{\frac{5}{2}}x + K$ be a common tangent of F and H.

Then $4(a^2 + b^2)$ is equal to _____.

[28-Jul-2022-Shift-1]

Answer: 3

Solution:

The equation of tangent to hyperbola $x^2 - y^2 = 1$ within slope m is equal to $y = mx \pm \sqrt{m^2 - 1}$.

And for same slope m, equation of tangent to ellipse $\frac{x^2}{a^2} + \frac{y^2}{b^2} = 1$ is $y = mx \pm \sqrt{a^2 m^2 + b^2} \dots (ii)$

∴ Equation (i) and (ii) are identical

$$\therefore a^2 m^2 + b^2 = m^2 - 1$$

$$\therefore m^2 = \frac{1+b^2}{1-a^2}$$

But equation of common tangent is $y = \sqrt{\frac{5}{2}}x + k$

$$\therefore m = \sqrt{\frac{5}{2}} \Rightarrow \frac{5}{2} = \frac{1+b^2}{1-a^2}$$

$$\therefore 5a^2 + 2b^2 = 3 \dots\dots (i)$$

$$\text{eccentricity of ellipse} = \frac{1}{\sqrt{2}}$$

$$\therefore 1 - \frac{b^2}{a^2} = \frac{1}{2}$$

$$\Rightarrow a^2 = 2b^2 \dots\dots\dots (ii)$$

From equation (i) and (ii) : $a^2 = \frac{1}{2}, b^2 = \frac{1}{4}$

$$\therefore 4(a^2 + b^2) = 3$$

Question 174

Let the hyperbola $H : \frac{x^2}{a^2} - \frac{y^2}{b^2} = 1$ pass through the point $(2\sqrt{2}, -2\sqrt{2})$. A parabola is drawn whose focus is same as the focus of H with positive abscissa and the directrix of the parabola passes through the other focus of H . If the length of the latus rectum of the parabola is e times the length of the latus rectum of H , where e is the eccentricity of H , then which of the following points lies on the parabola?

[28-Jul-2022-Shift-2]

Options:

A. $(2\sqrt{3}, 3\sqrt{2})$

B. $(3\sqrt{3}, -6\sqrt{2})$

C. $(\sqrt{3}, -\sqrt{6})$

D. $(3\sqrt{6}, 6\sqrt{2})$

Answer: B

Solution:

Solution:

$$H : \frac{x^2}{a^2} - \frac{y^2}{b^2} = 1$$

Focus of parabola : $(ae, 0)$

Directrix : $x = -ae$.

Equation of parabola $\equiv y^2 = 4aex$

Length of latus rectum of parabola = $4ae$

Length of latus rectum of hyperbola = $\frac{2 \cdot b^2}{a}$

$$\text{as given, } 4ae = \frac{2b^2}{a} \cdot e$$

$$2 = \frac{b^2}{a^2} \dots\dots (i)$$

$$\therefore H \text{ passes through } (2\sqrt{2}, -2\sqrt{2}) \Rightarrow \frac{8}{a^2} - \frac{8}{b^2} = 1 \dots\dots (ii)$$

From (i) and (ii) $a^2 = 4$ and $b^2 = 8 \Rightarrow e = \sqrt{3}$

\Rightarrow Equation of parabola is $y^2 = 8\sqrt{3}x$.

Question 175

Let the focal chord of the parabola $P : y^2 = 4x$ along the line $L : y = mx + c$, $m > 0$ meet the parabola at the points M and N . Let the line L be a tangent to the hyperbola $H : x^2 - y^2 = 4$. If O is the vertex of P and F is the focus of H on the positive x -axis, then the area of the quadrilateral $OMFN$ is :
 [29-Jul-2022-Shift-1]

Options:

- A. $2\sqrt{6}$
- B. $2\sqrt{14}$
- C. $4\sqrt{6}$
- D. $4\sqrt{14}$

Answer: B

Solution:

Solution:

$$H : \frac{x^2}{4} - \frac{y^2}{4} = 1$$

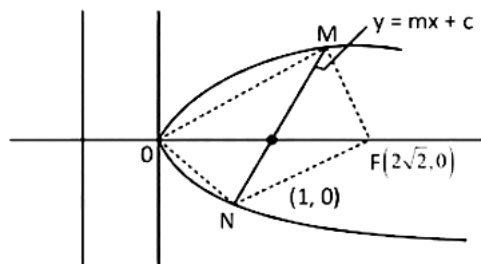

Focus $(ac, 0)$

$F(2\sqrt{2}, 0)$

$y = mx + c$ passes through $(1, 0)$

$$0 = m + C \dots\dots (i)$$

L is tangent to hyperbola

$$C = \pm \sqrt{4m^2 - 4}$$

$$-m = \pm \sqrt{4m^2 - 4}$$

$$m^2 = 4m^2 - 4$$

$$m = \frac{2}{\sqrt{3}}$$

$$C = \frac{-2}{\sqrt{3}}$$

$$T : y = \frac{2}{\sqrt{3}}x - \frac{2}{\sqrt{3}}$$

$$P : y^2 = 4x$$

$$y^2 = 4 \left(\frac{\sqrt{3}y + 2}{2} \right)$$

$$y^2 - 2\sqrt{3}y - 4 = 0$$

Area

$$\frac{1}{2} \begin{vmatrix} 0 & 0 \\ x_1 & y_1 \\ 2\sqrt{2} & 0 \\ x_2 & y_2 \\ 0 & 0 \end{vmatrix}$$

Question 176

Let the locus of the centre (α, β) , $\beta > 0$, of the circle which touches the circle $x^2 + (y - 1)^2 = 1$ externally and also touches the x-axis be L. Then the area bounded by L and the line $y = 4$ is:

[25-Jul-2022-Shift-1]

Options:

- A. $\frac{32\sqrt{2}}{3}$
- B. $\frac{40\sqrt{2}}{3}$
- C. $\frac{64}{3}$
- D. $\frac{32}{3}$

Answer: C

Solution:

Solution:

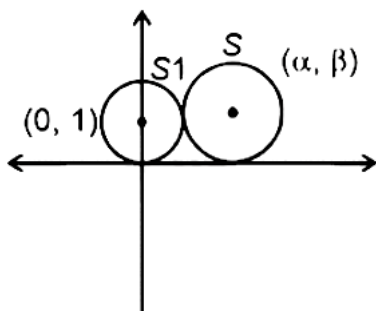

Radius of circle S touching x-axis and centre (α, β) is $|\beta|$. According to given conditions

$$\alpha^2 + (\beta - 1)^2 = (|\beta| + 1)^2$$

$$\alpha^2 + \beta^2 - 2\beta + 1 = \beta^2 + 1 + 2|\beta|$$

$$\alpha^2 = 4\beta \text{ as } \beta > 0$$

\therefore Required locus is L : $x^2 = 4y$

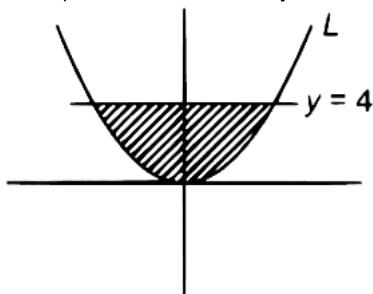

The area of shaded region $= 2 \int_0^4 2\sqrt{y} dy$

$$= 4 \cdot \left[\frac{y^{3/2}}{3/2} \right]_0^4$$

$$= \frac{64}{3} \text{ square units.}$$

Question 177

If the circles $x^2 + y^2 + 6x + 8y + 16 = 0$ and $x^2 + y^2 + 2(3 - \sqrt{3})x + 2(4 - \sqrt{6})y = k + 6\sqrt{3} + 8\sqrt{6}$, $k > 0$, touch internally at the point $P(\alpha, \beta)$, then $(\alpha + \sqrt{3})^2 + (\beta + \sqrt{6})^2$ is equal to

[25-Jul-2022-Shift-2]

Options:

Answer: 25

Solution:

Solution:

The circle $x^2 + y^2 + 6x + 8y + 16 = 0$ has centre $(-3, -4)$ and radius 3 units,

The circle $x^2 + y^2 + 2(3 - \sqrt{3})x + 2(4 - \sqrt{6})y = k + 6\sqrt{3} + 8\sqrt{6}$, $k > 0$ has centre $(\sqrt{3} - 3, \sqrt{6} - 4)$ and radius $\sqrt{k + 34}$

∴ These two circles touch internally hence

$$\sqrt{3+6} = |\sqrt{k+34} - 3|$$

Here, $k = 2$ is only possible ($\because k > 0$)

Equation of common tangent to two circles is $2\sqrt{3}x + 2\sqrt{6}y + 16 + 6\sqrt{3} + 8\sqrt{6} + k = 0$

∴ $k = 2$ then equation is

$$x + \sqrt{2}y + 3 + 4\sqrt{2} + 3\sqrt{3} = 0 \dots\dots (i)$$

∴ (α, β) are foot of perpendicular from $(-3, -4)$

To line (i) then

$$\frac{\alpha + 3}{1} = \frac{\beta + 4}{\sqrt{2}} = \frac{-(-3 - 4\sqrt{2} + 3 + 4\sqrt{2} + 3\sqrt{3})}{1 + 2}$$

$$\therefore \alpha + 3 = \frac{\beta + 4}{\sqrt{2}} = -\sqrt{3}$$

$$\Rightarrow (\alpha + \sqrt{3})^2 = 9 \text{ and } (\beta + \sqrt{6})^2 = 16$$

$$\therefore (\alpha + \sqrt{3})^2 + (\beta + \sqrt{6})^2 = 25$$

Question 178

If the circle $x^2 + y^2 - 2gx + 6y - 19c = 0$, $g, c \in \mathbb{R}$ passes through the point $(6, 1)$ and its centre lies on the line $x - 2cy = 8$, then the length of intercept made by the circle on x-axis is
[27-Jul-2022-Shift-1]

Options:

A. $\sqrt{11}$

B. 4

C. 3

D. $2\sqrt{23}$

Answer: D

Solution:

Circle : $x^2 + y^2 - 2gx + 6y - 19c = 0$

It passes through $h(6, 1)$

$$\Rightarrow 36 + 1 - 12g + 6 - 19c = 0$$

$$= 12g + 19c = 43 \dots\dots (1)$$

Line $x - 2cy = 8$ passes through centre

$$\Rightarrow g + 6c = 8 \dots\dots (2)$$

From (1) & (2)

$$g = 2, c = 1$$

$$C : x^2 + y^2 - 4x + 6y - 19 = 0$$

$$x_{int} = 2\sqrt{g^2 - C}$$

$$= 2\sqrt{4 + 19}$$

$$= 2\sqrt{23}$$

Question 179

A circle C_1 passes through the origin O and has diameter 4 on the positive x -axis. The line $y = 2x$ gives a chord OA of circle C_1 . Let C_2 be the circle with OA as a diameter. If the tangent to C_2 at the point A meets the x -axis at P and y -axis at Q , then $QA : AP$ is equal to:
[27-Jul-2022-Shift-2]

Options:

- A. 1 : 4
- B. 1 : 5
- C. 2 : 5
- D. 1 : 3

Answer: A

Solution:

Equation of C_1

$$x^2 + y^2 - 4x = 0$$

Intersection with

$$y = 2x$$

$$x^2 + 4x^2 - 4x = 0$$

$$5x^2 - 4x = 0$$

$$\Rightarrow x = 0, \frac{4}{5}$$

$$y = 0, \frac{8}{5}$$

$$A : \left(\frac{4}{5}, \frac{8}{5} \right)$$

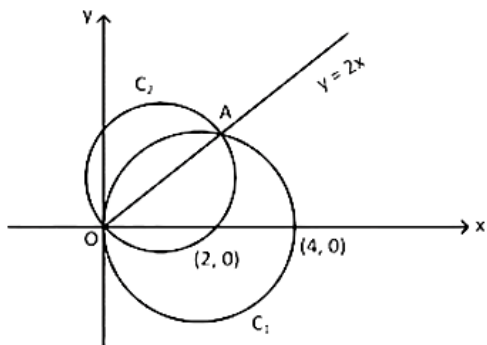

Tangent of C_2 at $A \left(\frac{4}{5}, \frac{8}{5} \right)$

$$x + 2y = 4 \Rightarrow P : (4, 0), Q : (0, 2)$$

$$QA : AP = 1 : 4$$

Question 180

Let C be the centre of the circle $x^2 + y^2 - x + 2y = \frac{11}{4}$ and P be a point on the circle. A line passes through the point C , makes an angle of $\frac{\pi}{4}$ with the line CP and intersects the circle at the points Q and R . Then the area of the triangle PQR (in unit²) is :
[28-Jul-2022-Shift-1]

Options:

- A. 2
- B. $2\sqrt{2}$

C. $8 \sin\left(\frac{\pi}{8}\right)$

D. $8 \cos\left(\frac{\pi}{8}\right)$

Answer: B

Solution:

Solution:

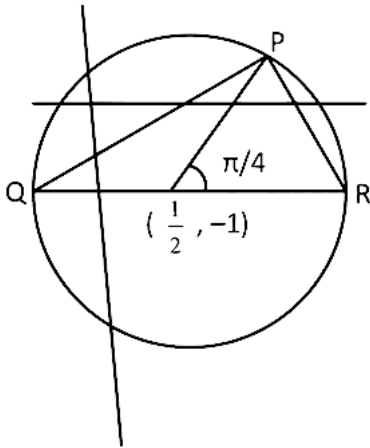

$QR = 2r = 4$

$P = \left(\frac{1}{2} + 2 \cos \frac{\pi}{4}, -1 + 2 \sin \frac{\pi}{4}\right)$

$= \left(\frac{1}{2} + \sqrt{2}, -1 + \sqrt{2}\right)$

Area of $\triangle PQR = \frac{1}{2} \times 4 \times \sqrt{2} = 2\sqrt{2}$ sq. units

Question 181

Let the tangents at two points A and B on the circle $x^2 + y^2 - 4x + 3 = 0$ meet at origin $O(0, 0)$. Then the area of the triangle OAB is :

[28-Jul-2022-Shift-2]

Options:

A. $\frac{3\sqrt{3}}{2}$

B. $\frac{3\sqrt{3}}{4}$

C. $\frac{3}{2\sqrt{3}}$

D. $\frac{3}{4\sqrt{3}}$

Answer: B

Solution:

$x^2 + y^2 - 4x + 3 = 0$

$\Rightarrow (x - 2)^2 + y^2 = 1$

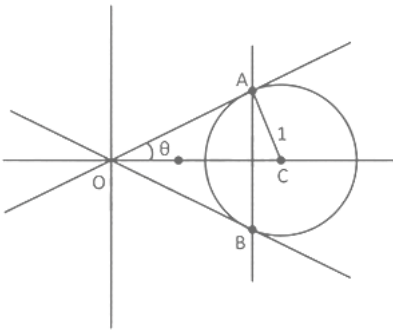

$$AO = \sqrt{(OC)^2 - (AC)^2}$$

$$= \sqrt{4 - 1} = \sqrt{3}$$

$$\sin\theta = \frac{1}{2} \Rightarrow \theta = \frac{\pi}{6}$$

Also, $AO = BO$

$$\text{Area of } \triangle OAB = \frac{1}{2} \cdot OA \cdot OB \sin 60^\circ$$

$$= \frac{1}{2} \times \sqrt{3} \cdot \sqrt{3} \cdot \frac{\sqrt{3}}{2} = \frac{3\sqrt{3}}{4}$$

Question 182

Let a line L pass through the point of intersection of the lines $bx + 10y - 8 = 0$ and $2x - 3y = 0$, $b \in \mathbb{R} - \left\{ \frac{4}{3} \right\}$. If the line L also passes through the point $(1, 1)$ and touches the circle $17(x^2 + y^2) = 16$, then the eccentricity of the ellipse $\frac{x^2}{5} + \frac{y^2}{b^2} = 1$ is :

[29-Jul-2022-Shift-1]

Options:

A. $\frac{2}{\sqrt{5}}$

B. $\sqrt{\frac{3}{5}}$

C. $\frac{1}{\sqrt{5}}$

D. $\sqrt{\frac{2}{5}}$

Answer: A

Solution:

$$L_1 : bx + 10y - 8 = 0, L_2 : 2x - 3y = 0$$

$$\text{then } L : (bx + 10y - 8) + \lambda(2x - 3y) = 0$$

\therefore It passes through $(1, 1)$

$$\therefore b + 2 - \lambda = 0 \Rightarrow \lambda = b + 2$$

$$\text{and touches the circle } x^2 + y^2 = \frac{16}{17}$$

$$\left| \frac{8^2}{(2\lambda + b)^2 + (10 - 3\lambda)^2} \right| = \frac{16}{17}$$

$$\Rightarrow 4\lambda^2 + b^2 + 4b\lambda + 100 + 9\lambda^2 - 60\lambda = 68$$

$$\Rightarrow 13(b + 2)^2 + b^2 + 4b(b + 2) - 60(b + 2) + 32 = 0$$

$$\Rightarrow 18b^2 = 36$$

$$\therefore b^2 = 2$$

∴ Eccentricity of ellipse : $\frac{x^2}{5} + \frac{y^2}{b^2} = 1$ is

$$\therefore e = \sqrt{1 - \frac{2}{5}} = \sqrt{\frac{3}{5}}$$

Question 183

Let the mirror image of a circle $c_1 : x^2 + y^2 - 2x - 6y + \alpha = 0$ in line $y = x + 1$ be

$c_2 : 5x^2 + 5y^2 + 10gx + 10fy + 38 = 0$. If r is the radius of circle c_2 , then $\alpha + 6r^2$ is equal to _____.

[29-Jul-2022-Shift-1]

Answer: 12

Solution:

Solution:

$$c_1 : x^2 + y^2 - 2x - 6y + \alpha = 0$$

Then centre = (1, 3) and radius (r) = $\sqrt{10 - \alpha}$

Image of (1, 3) w.r.t. line $x - y + 1 = 0$ is (2, 2)

$$c_2 : 5x^2 + 5y^2 + 10gx + 10fy + 38 = 0$$

$$\text{or } x^2 + y^2 + 2gx + 2fy + \frac{38}{5} = 0$$

Then $(-g, -f) = (2, 2)$

$$\therefore g = f = -2 \dots \dots \dots (i)$$

$$\text{Radius of } c_2 = r = \sqrt{4 + 4 - \frac{38}{5}} = \sqrt{10 - \alpha}$$

$$\Rightarrow \frac{2}{5} = 10 - \alpha$$

$$\therefore \alpha = \frac{48}{5} \text{ and } r = \sqrt{\frac{2}{5}}$$

$$\therefore \alpha + 6r^2 = \frac{48}{5} + \frac{12}{5} = 12$$

Question 184

Let AB be a chord of length 12 of the circle $(x - 2)^2 + (y + 1)^2 = \frac{169}{4}$. If tangents drawn to the circle at points A and B intersect at the point P, then five times the distance of point P from chord AB is equal to

_____.

[29-Jul-2022-Shift-2]

Answer: 72

Solution:

Solution:

Here $AM = BM = 6$

$$OM = \sqrt{\left(\frac{13}{2}\right)^2 - 6^2} = \frac{5}{2}$$

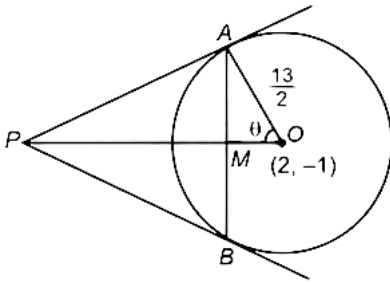

$$\sin \theta = \frac{12}{13}$$

In $\triangle PAO$:

$$\frac{PO}{OA} = \sec \theta$$

$$PO = \frac{13}{2} \cdot \frac{13}{5} = \frac{169}{10}$$

$$\therefore PM = \frac{169}{10} - \frac{5}{2} = \frac{144}{10} = \frac{72}{5}$$

$$\therefore 5PM = 72$$

Question 185

The sum of diameters of the circles that touch (i) the parabola $75x^2 = 64(5y - 3)$ at the point $\left(\frac{8}{5}, \frac{6}{5}\right)$ and (ii) the y-axis, is equal to
[25-Jul-2022-Shift-1]

Answer: 10

Solution:

Solution:

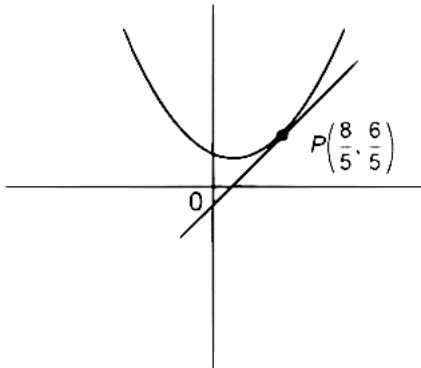

Equation of tangent to the parabola at $P\left(\frac{8}{5}, \frac{6}{5}\right)$

$$75x \cdot \frac{8}{5} = 160\left(y + \frac{6}{5}\right) - 192$$

$$\Rightarrow 120x = 160y$$

$$\Rightarrow 3x = 4y$$

Equation of circle touching the given parabola at P can be taken as

$$\left(x - \frac{8}{5}\right)^2 + \left(y - \frac{6}{5}\right)^2 + \lambda(3x - 4y) = 0$$

If this circle touches y-axis then

$$\frac{64}{25} + \left(y - \frac{6}{5}\right)^2 + \lambda(-4y) = 0$$

$$\Rightarrow y^2 - 2y\left(2\lambda + \frac{6}{5}\right) + 4 = 0$$

$$\Rightarrow D = 0$$

$$\Rightarrow \left(2\lambda + \frac{6}{5}\right)^2 = 4$$



$$\Rightarrow \lambda = \frac{2}{5} \text{ or } -\frac{8}{5}$$

Radius = 1 or 4

Sum of diameter = 10

Question 186

The tangents at the points A(1, 3) and B(1, -1) on the parabola $y^2 - 2x - 2y = 1$ meet at the point P. Then the area (in unit²) of the triangle PAB is:

[25-Jul-2022-Shift-2]

Options:

A. 4

B. 6

C. 7

D. 8

Answer: D

Solution:

Solution:

Given curve : $y^2 - 2x - 2y = 1$.

Can be written as

$$(y - 1)^2 = 2(x + 1)$$

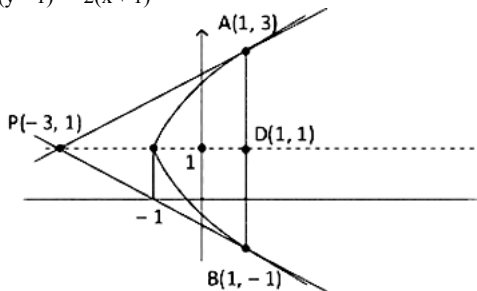

And, the given information can be plotted as shown in figure

Tangent at A : $2y - x - 5 = 0$ using $T = 0$ }

Intersection with $y = 1$ is $x = -3$

Hence, point P is $(-3, 1)$

Taking advantage of symmetry

$$\text{Area of } \triangle PAB = 2 \times \frac{1}{2} \times (1 - (-3)) \times (3 - 1)$$

$$= 8 \text{ sq. units}$$

Question 187

Let the function $f(x) = 2x^2 - \log_e x$, $x > 0$, be decreasing in $(0, a)$ and increasing in $(a, 4)$. A tangent to the parabola $y^2 = 4ax$ at a point P on it passes through the point $(8a, 8a - 1)$ but does not pass through the point $(-\frac{1}{a}, 0)$. If the equation of the normal at P is : $\frac{x}{\alpha} + \frac{y}{\beta} = 1$, then $\alpha + \beta$ is equal to _____.

[26-Jul-2022-Shift-1]

Answer: 45

Solution:

Solution:

$f'(x) = \frac{4x^2-1}{x}$ so $f(x)$ is decreasing in $(0, \frac{1}{2})$ and increasing in $(\frac{1}{2}, \infty) \Rightarrow a = \frac{1}{2}$

Tangent at $y^2 = 2x \Rightarrow y = x + \frac{1}{2m}$

It is passing through $(4, 3)$

$$3 = 4m + \frac{1}{2m} \Rightarrow m = \frac{1}{2} \text{ or } \frac{1}{4}$$

So tangent may be

$$y = \frac{1}{2}x + 1 \text{ or } y = \frac{1}{4}x + 2$$

But $y = \frac{1}{2}x + 1$ passes through $(-2, 0)$ so rejected.

Equation of normal

$$y = -4x - 2\left(\frac{1}{2}\right)(-4) - \frac{1}{2}(-4)^3$$

$$\text{or } y = -4x + 4 + 32$$

$$\text{or } \frac{x}{9} + \frac{y}{36} = 1$$

Question 188

Let P and Q be any points on the curves $(x-1)^2 + (y+1)^2 = 1$ and $y = x^2$, respectively. The distance between P and Q is minimum for some value of the abscissa of P in the interval [26-Jul-2022-Shift-2]

Options:

A. $(0, \frac{1}{4})$

B. $(\frac{1}{2}, \frac{3}{4})$

C. $(\frac{1}{4}, \frac{1}{2})$

D. $(\frac{3}{4}, 1)$

Answer: C

Solution:

Solution:

$y = mx + 2a + \frac{1}{m^2}$ (Equation of normal to $x^2 = 4ay$ in slope form) through $(1, -1)$.

$$4m^3 + 6m^2 + 1 = 0$$

$$\Rightarrow m \approx -1.6$$

$$\text{Slope of normal} \approx \frac{-8}{5} = \tan \theta$$

$$\Rightarrow \cos \theta \approx \frac{-5}{\sqrt{89}}, \sin \theta \approx \frac{8}{\sqrt{89}}$$

$$x_p = 1 + \cos \theta \approx 1 - \frac{5}{\sqrt{89}} \in \left(\frac{1}{4}, \frac{1}{2}\right)$$

Question 189

The equation of a common tangent to the parabolas $y = x^2$ and $y = -(x-2)^2$ is [26-Jul-2022-Shift-2]

Options:

A. $y = 4(x - 2)$

B. $y = 4(x - 1)$

C. $y = 4(x + 1)$

D. $y = 4(x + 2)$

Answer: B

Solution:

Solution:

Equation of tangent of slope m to $y = x^2$

$$y = mx - \frac{1}{4}m^2$$

Equation of tangent of slope m to $y = -(x - 2)^2$

$$y = m(x - 2) + \frac{1}{4}m^2$$

If both equation represent the same line

$$\frac{1}{4}m^2 - 2m = -\frac{1}{4}m^2$$

$$m = 0, 4$$

So, equation of tangent

$$y = 4x - 4$$

Question 190

Let $P(a, b)$ be a point on the parabola $y^2 = 8x$ such that the tangent at P passes through the centre of the circle $x^2 + y^2 - 10x - 14y + 65 = 0$. Let A be the product of all possible values of a and B be the product of all possible values of b . Then the value of $A + B$ is equal to
[27-Jul-2022-Shift-1]

Options:

A. 0

B. 25

C. 40

D. 65

Answer: D

Solution:

Solution:

Centre of circle $x^2 + y^2 - 10x - 14y + 65 = 0$ is at $(5, 7)$

Let the equation of tangent to $y^2 = 8x$ is

$$yt = x + 2t^2$$

which passes through $(5, 7)$

$$7t = 5 + 2t^2$$

$$\Rightarrow 2t^2 - 7t + 5 = 0$$

$$t = 1, \frac{5}{2}$$

$$A = 2 \times 1^2 \times 2 \times \left(\frac{5}{2}\right)^2 = 25$$

$$B = 2 \times 2 \times 1 \times 2 \times 2 \times \frac{5}{2} = 40$$

$$A + B = 65$$

Question191

If the length of the latus rectum of a parabola, whose focus is (a, a) and the tangent at its vertex is $x + y = a$, is 16, then $|a|$ is equal to :

[27-Jul-2022-Shift-2]

Options:

A. $2\sqrt{2}$

B. $2\sqrt{3}$

C. $4\sqrt{2}$

D. 4

Answer: C

Solution:

Solution:

Equation of tangent at vertex: $L \equiv x + y - a = 0$

Focus : $F \equiv (a, a)$

Perpendicular distance of L from F

$$= \left| \frac{a+a-a}{\sqrt{2}} \right| = \left| \frac{a}{\sqrt{2}} \right|$$

$$\text{Length of latus rectum} = 4 \left| \frac{a}{\sqrt{2}} \right|$$

$$\text{Given } 4 \left| \frac{a}{\sqrt{2}} \right| = 16$$

$$\Rightarrow |a| = 4\sqrt{2}$$

Question192

If the tangents drawn at the points P and Q on the parabola $y^2 = 2x - 3$ intersect at the point $R(0, 1)$, then the orthocentre of the triangle PQR is:

[28-Jul-2022-Shift-1]

Options:

A. $(0, 1)$

B. $(2, -1)$

C. $(6, 3)$

D. $(2, 1)$

Answer: B

Solution:

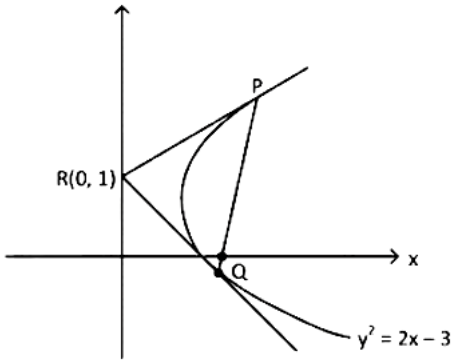

Equation of chord PQ

$$\Rightarrow y \times 1 = x - 3$$

$$\Rightarrow x - y = 3$$

For point P & Q

Intersection of PQ with parabola P : (6, 3) Q : (2, -1)

Slope of RQ = -1 & slope of PQ = 1

Therefore $\angle PQR = 90^\circ \Rightarrow$ Orthocentre is at Q : (2, -1)

Question193

Two tangent lines l_1 and l_2 are drawn from the point (2, 0) to the parabola $2y^2 = -x$. If the lines l_1 and l_2 are also tangent to the circle $(x - 5)^2 + y^2 = r$, then $17r$ is equal to _____.

[28-Jul-2022-Shift-2]

Answer: 9

Solution:

$$\text{Given : } y^2 = \frac{-x}{2}$$

$$cT \equiv y = mx - \frac{1}{8m}$$

$$\downarrow (2, 0)$$

$$\Rightarrow m^2 = \frac{1}{16} \Rightarrow m = \pm \frac{1}{4}$$

$$\text{Tangents are } y = \frac{1}{4}x - \frac{1}{2}, y = \frac{-x}{4} + \frac{1}{2}$$

$$4y = x - 2 \text{ and } 4y + x = 2$$

If these are also tangent to circle then $d_c = r$

$$\Rightarrow \left| \frac{5-2}{\sqrt{17}} \right| = \sqrt{r} \Rightarrow r = \left(\frac{3}{\sqrt{17}} \right)^2$$

$$\Rightarrow 17r = 17 \cdot \frac{9}{17} = 9$$

Question194

The area of the region given by $A = \{(x, y) : x^2 \leq y \leq \min\{x + 2, 4 - 3x\}\}$ is :

[25-Jul-2022-Shift-1]

Options:

A. $\frac{31}{8}$



B. $\frac{17}{6}$

C. $\frac{19}{6}$

D. $\frac{27}{8}$

Answer: B

Solution:

Solution:

$$A = \{(x, y) : x^2 \leq y \leq \min\{x+2, 4-3x\}\}.$$

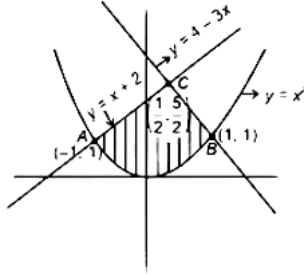

So area of required region

$$A = \int_{-1}^0 (x+2-x^2) dx + \int_0^1 (4-3x-x^2) dx$$

$$= \left[\frac{x^2}{2} + 2x - \frac{x^3}{3} \right]_{-1}^0 + \left[4x - \frac{3x^2}{2} - \frac{x^3}{3} \right]_0^1$$

$$= \left(\frac{1}{8} + 1 - \frac{1}{24} \right) - \left(\frac{1}{2} - 2 + \frac{1}{3} \right) + \left(4 - \frac{3}{2} - \frac{1}{3} \right) - \left(2 - \frac{3}{8} - \frac{1}{24} \right)$$

$$= \frac{17}{6}$$

Question 195

If the ellipse $\frac{x^2}{a^2} + \frac{y^2}{b^2} = 1$ meets the line $\frac{x}{7} + \frac{y}{2\sqrt{6}} = 1$ on the x-axis and the line $\frac{x}{7} - \frac{y}{2\sqrt{6}} = 1$ on the y-axis, then the eccentricity of the ellipse is
[25-Jul-2022-Shift-2]

Options:

A. $\frac{5}{7}$

B. $\frac{2\sqrt{6}}{7}$

C. $\frac{3}{7}$

D. $\frac{2\sqrt{5}}{7}$

Answer: A

Solution:

$$\frac{x^2}{a^2} + \frac{y^2}{b^2} = 1 \text{ meets the line } \frac{x}{7} + \frac{y}{2\sqrt{6}} = 1 \text{ on the x-axis So, } a = 7$$

$$\text{and } \frac{x^2}{a^2} + \frac{y^2}{b^2} = 1 \text{ meets the line } \frac{x}{7} - \frac{y}{2\sqrt{6}} = 1 \text{ on the y-axis So, } b = 2\sqrt{6}$$

$$\text{Therefore, } e^2 = 1 - \frac{b^2}{a^2} = 1 - \frac{24}{49}$$

$$e = \frac{5}{7}$$

Question 196

The acute angle between the pair of tangents drawn to the ellipse $2x^2 + 3y^2 = 5$ from the point (1, 3) is [26-Jul-2022-Shift-2]

Options:

A. $\tan^{-1}\left(\frac{16}{7\sqrt{5}}\right)$

B. $\tan^{-1}\left(\frac{24}{7\sqrt{5}}\right)$

C. $\tan^{-1}\left(\frac{32}{7\sqrt{5}}\right)$

D. $\tan^{-1}\left(\frac{3+8\sqrt{5}}{35}\right)$

Answer: B

Solution:

Solution:

$$2x^2 + 3y^2 = 5$$

Equation of tangent having slope m.

$$y = mx \pm \sqrt{\frac{5}{2}m^2 + \frac{5}{3}}$$

which passes through (1, 3)

$$3 = m \pm \sqrt{\frac{5}{2}m^2 + \frac{5}{3}}$$

$$\frac{5}{2}m^2 + \frac{5}{3} = 9 + m^2 - 6m$$

$$\frac{3}{2}m^2 + 6m - \frac{22}{3} = 0$$

$$9m^2 + 36m - 44 = 0$$

$$m_1 + m_2 = -4, m_1 m_2 = -\frac{44}{9}$$

$$(m_1 - m_2)^2 = 16 + 4 \times \frac{44}{9} = \frac{320}{9}$$

Acute angle between the tangents is given by

$$\alpha = \tan^{-1} \left| \frac{m_1 - m_2}{1 + m_1 m_2} \right|$$

$$= \tan^{-1} \left| \frac{\frac{8\sqrt{5}}{3}}{1 - \frac{44}{9}} \right|$$

$$= \tan^{-1} \left(\frac{24\sqrt{5}}{35} \right)$$

$$\alpha = \tan^{-1} \left(\frac{24}{7\sqrt{5}} \right)$$

Question 197

If the length of the latus rectum of the ellipse $x^2 + 4y^2 + 2x + 8y - \lambda = 0$ is 4, and l is the length of its major axis, then $\lambda + l$ is equal to _____.

[27-Jul-2022-Shift-1]

Answer: 75

Solution:

Solution:

Equation of ellipse is : $x^2 + 4y^2 + 2x + 8y - \lambda = 0$

$$(x+1)^2 + 4(y+1)^2 = \lambda + 5$$

$$\frac{(x+1)^2}{\lambda+5} + \frac{(y+1)^2}{\left(\frac{\lambda+5}{4}\right)} = 1$$

$$\text{Length of latus rectum} = \frac{2 \cdot \left(\frac{\lambda+5}{4}\right)}{\sqrt{\lambda+5}} = 4.$$

$$\therefore \lambda = 59$$

$$\text{Length of major axis} = 2 \cdot \sqrt{\lambda+5} = 16 = l$$

$$\therefore \lambda + l = 75.$$

Question 198

Let the tangents at the points P and Q on the ellipse $\frac{x^2}{2} + \frac{y^2}{4} = 1$ meet at the point $R(\sqrt{2}, 2\sqrt{2} - 2)$. If S is the focus of the ellipse on its negative major axis, then $SP^2 + SQ^2$ is equal to _____.

[28-Jul-2022-Shift-2]

Answer: 13

Solution:

Solution:

$$E \equiv \frac{x^2}{2} + \frac{y^2}{4} = 1$$

$$T \equiv y = mx \pm \sqrt{2m^2 + 4}$$

$$\downarrow (\sqrt{2}, 2\sqrt{2} - 2)$$

$$\Rightarrow (2\sqrt{2} - 2 - m\sqrt{2}) = \pm \sqrt{2m^2 + 4}$$

$$\Rightarrow 2m^2 - 2m\sqrt{2}(2\sqrt{2} - 2) + 4(3 - 2\sqrt{2}) = 2m^2 + 4$$

$$\Rightarrow -2\sqrt{2}m(2\sqrt{2} - 2) = 4 - 12 + 8\sqrt{2}$$

$$\Rightarrow -4\sqrt{2}m(\sqrt{2} - 1) = 8(\sqrt{2} - 1)$$

$$\Rightarrow m = -\sqrt{2} \text{ and } m \rightarrow \infty$$

$$\therefore \text{Tangents are } x = \sqrt{2} \text{ and } y = -\sqrt{2}x + \sqrt{8}$$

$$\therefore P(\sqrt{2}, 0) \text{ and } Q(1, \sqrt{2})$$

$$\text{and } S = (0, -\sqrt{2})$$

$$\therefore (PS)^2 + (QS)^2 = 4 + 9 = 13$$

Question 199

Let $S = \{(x, y) \in \mathbb{N} \times \mathbb{N} : 9(x-3)^2 + 16(y-4)^2 \leq 144\}$ and $T = \{(x, y) \in \mathbb{R} \times \mathbb{R} : (x-7)^2 + (y-4)^2 \leq 36\}$. Then $n(S \cap T)$ is equal to _____.

[29-Jul-2022-Shift-2]

Answer: 27

Solution:

Solution:

$$S: \frac{(x-3)^2}{16} + \frac{(y-4)^2}{9} \leq 1; x, y \in \{1, 2, 3, \dots\}$$

$$T: (x-7)^2 + (y-4)^2 \leq 36x, y \in \mathbb{R}$$

$$\text{Let } x-3 = x : y-4 = y$$

$$S: \frac{x^2}{16} + \frac{y^2}{9} \leq 1; x \in \{-2, -1, 0, 1, \dots\}$$

$$T: (x-4)^2 + y^2 \leq 36; y \in \{-3, -2, -1, 0, \dots\}$$

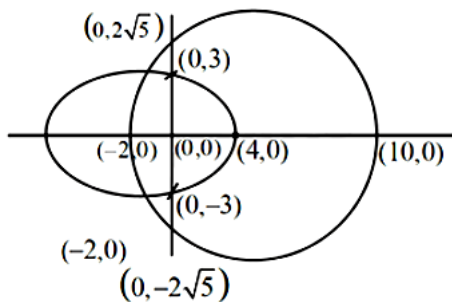

$$S \cap T = (-2, 0), (-1, 0), \dots, (4, 0) \rightarrow (7)$$

$$(-1, 1), (0, 1), \dots, (3, 1) \rightarrow (5)$$

$$(-1, -1), (0, -1), \dots, (3, -1) \rightarrow (5)$$

$$(-1, 2), (0, 2), (1, 2), (2, 2) \rightarrow (4)$$

$$(-1, -2), (0, -2), (1, -2), (2, -2) \rightarrow (4)$$

$$(0, 3)(0, -3) \rightarrow (2)$$

Question 200

Let a point P be such that its distance from the point (5, 0) is thrice the distance of P from the point (-5, 0).

If the locus of the point P is a circle of radius r, then $4r^2$ is equal to

[2021, 24 Feb. Shift-II]

Answer: 56.25

Solution:

Solution:

Let P be (h, k), A(5, 0) and B(-5, 0).

Given PA = 3PB

$$\Rightarrow PA^2 = 9PB^2$$

$$\Rightarrow (h-5)^2 + k^2 = 9[(h+5)^2 + k^2]$$

$$\Rightarrow 8h^2 + 8k^2 + 100h + 200 = 0$$

$$\therefore \text{Locus of P is } x^2 + y^2 + \frac{25}{2}x + 25 = 0$$

$$\text{Centre} = \left(-\frac{25}{4}, 0 \right)$$

$$\text{and } r^2 = \left(-\frac{25}{4} \right)^2 + 0^2 - 25$$

$$= \frac{625}{16} - 25 = \frac{225}{16}$$

$$\therefore 4r^2 = 4 \times \frac{225}{16} = \frac{225}{4} = 56.25$$

Question201

If the point of intersections of the ellipse $\frac{x^2}{16} + \frac{y^2}{b^2} = 1$ and the circle $x^2 + y^2 = 4b$, $b > 4$, lie on the curve $y^2 = 3x^2$, then b is equal to
[2021, 16 March Shift-II]

Options:

- A. 12
- B. 5
- C. 6
- D. 10

Answer: A

Solution:

Solution:

Given, equation of ellipse $\frac{x^2}{16} + \frac{y^2}{b^2} = 1 \dots (i)$

and equation of circle $x^2 + y^2 = 4b \dots\dots\dots (ii)$

From Eqs. (i) and (ii),

$$\frac{4b - y^2}{16} + \frac{y^2}{b^2} = 1$$

$$\Rightarrow 4b^3 - y^2b^2 + 16y^2 = 16b^2$$

$$\Rightarrow y^2 = \frac{16b^2 - 4b^3}{16 - b^2}$$

As, (x, y) lie on $y^2 = 3x^2$

So, $y^2 = 3(4b - y^2)$ [from Eq. (ii)]

$$\Rightarrow 4y^2 = 12b$$

$$\Rightarrow y^2 = 3b$$

$$\text{Now, } \frac{16b^2 - 4b^3}{16 - b^2} = 3b$$

$$\Rightarrow 16b^2 - 4b^3 = 48b - 3b^3$$

$$\Rightarrow b^3 - 16b^2 + 48b = 0$$

$$\Rightarrow b(b^2 - 16b + 48) = 0$$

$$\Rightarrow b(b - 4)(b - 12) = 0$$

As, $b > 4$

So, $b = 12$

Question202

If one of the diameters of the circle $x^2 + y^2 - 2x - 6y + 6 = 0$ is a chord of another circle 'C', whose centre is at (2, 1), then its radius is [2021, 24 Feb. Shift-I]

Answer: 3

Solution:

Solution:

Given, circle $\Rightarrow x^2 + y^2 - 2x - 6y + 6 = 0$

Coordinate of C = (1, 3)

$$\text{Radius} = r = \sqrt{1^2 + 3^2 - 6} = \sqrt{4} = 2 \text{ units}$$

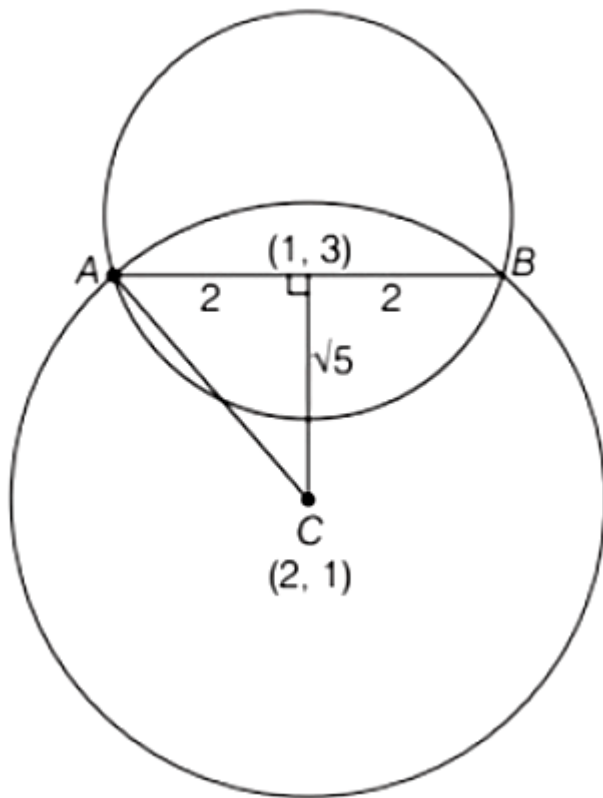

$$\begin{aligned} CD &= \sqrt{(2-1)^2 + (1-3)^2} \\ &= \sqrt{1+4} = \sqrt{5} \end{aligned}$$

$$\begin{aligned} \text{Now, by using Pythagoras theorem in } \triangle ADC, AC^2 &= AD^2 + CD^2 \\ &= (2)^2 + (\sqrt{5})^2 = 4 + 5 \end{aligned}$$

$$AC^2 = 9$$

$$AC = \sqrt{9} = 3$$

$$\therefore \text{Required radius} = 3$$

Question203

For which of the following curves, the line $x + \sqrt{3}y = 2\sqrt{3}$ is the tangent

at the point $\left(\frac{3\sqrt{3}}{2}, \frac{1}{2} \right)$?

[2021, 24 Feb. Shift-II]

Options:

A. $x^2 + y^2 = 7$

B. $y^2 = \frac{1}{6\sqrt{3}}x$

C. $2x^2 - 18y^2 = 9$

D. $x^2 + 9y^2 = 9$

Answer: D

Solution:

Solution:

Given, line $x + \sqrt{3}y = 2\sqrt{3}$

and point $\left(\frac{3\sqrt{3}}{2}, \frac{1}{2}\right)$

From options, we take the conic

$$x^2 + 9y^2 = 9$$

Equation of any tangent at (x_1, y_1) is

$$cxx_1 + 9 \cdot yy_1 = 9$$

$$\frac{3\sqrt{3}}{2}x + 9 \times \frac{1}{2} \times y = 9 \left[\because (x_1, y_1) = \left(\frac{3\sqrt{3}}{2}, \frac{1}{2}\right) \right]$$

$$\Rightarrow \frac{3\sqrt{3}}{2}(x + \sqrt{3}y) = 9$$

$$\Rightarrow x + \sqrt{3}y = \frac{9 \times 2}{3\sqrt{3}}$$

$$\Rightarrow x + \sqrt{3}y = 2\sqrt{3}$$

Clearly, $x + \sqrt{3}y = 2\sqrt{3}$ is a tangent to the curve $x^2 + 9y^2 = 9$.

Question204

If the locus of the mid-point of the line segment from the point (3, 2) to a point on the circle, $x^2 + y^2 = 1$ is a circle of radius r, then r is equal to [2021, 26 Feb. Shift-II]

Options:

A. 1

B. $\frac{1}{2}$

C. $\frac{1}{3}$

D. $\frac{1}{4}$

Answer: B

Solution:

Solution:

Given, circle $x^2 + y^2 = 1$

Let (h, k) be the mid-point of line segment from point $(3, 2)$ to a point on circle. Let point on circle be (a, b) .

Then, $h = \frac{a+3}{2}$

$\Rightarrow a = 2h - 3$

$k = \frac{b+2}{2}$

$\Rightarrow b = 2k - 2$

$\because (a, b)$ is point on circle, then

$(a)^2 + (b)^2 = 1$

$\Rightarrow (2h - 3)^2 + (2k - 2)^2 = 1$

$\Rightarrow \left(h - \frac{3}{2}\right)^2 + (k - 1)^2 = \frac{1}{4} = \left(\frac{1}{2}\right)^2$

Which is an equation of circle with radius $\frac{1}{2}$.

$\therefore \text{Radius} = \frac{1}{2}$.

Question205

Let $A(1, 4)$ and $B(1, -5)$ be two points. Let P be a point on the circle $(x - 1)^2 + (y - 1)^2 = 1$, such that $(PA)^2 + (PB)^2$ have maximum value, then the points P, A and B lie on

[2021, 26 Feb. Shift-III]

Options:

A. a straight line

B. a hyperbola

C. an ellipse

D. a parabola

Answer: A

Solution:

Solution:

P be a point on circle

$$(x - 1)^2 + (y - 1)^2 = 1$$

So, coordinate of P will be of

form $P(1 + \cos \theta, 1 + \sin \theta)$

Given,

$A(1, 4)$ and $B(1, -5)$

Then,

$$(PA)^2 + (PB)^2$$

$$= \cos^2 \theta + (\sin \theta - 3)^2 + \cos^2 \theta + (\sin \theta + 6)^2$$

$$= 2\cos^2 \theta + 2\sin^2 \theta - 6\sin \theta + 12\sin \theta + 45 = 47 + 6\sin \theta$$

Now,

$$(PA)^2 + (PB)^2 = 47 + 6\sin \theta \text{ is}$$

Maximum, when $\sin \theta = 1$

$$\Rightarrow \theta = \frac{\pi}{2}$$

$$\Rightarrow \cos \theta = 0$$

$\therefore P(1, 2), A(1, 4), B(1, -5)$

$\therefore P, B$ are collinear points on the line

$$x = 1$$

Question 206

In the circle given below, let $OA = 1$ unit, $OB = 13$ unit and $PQ \perp OB$. Then, the area of the triangle PQB (in square units) is

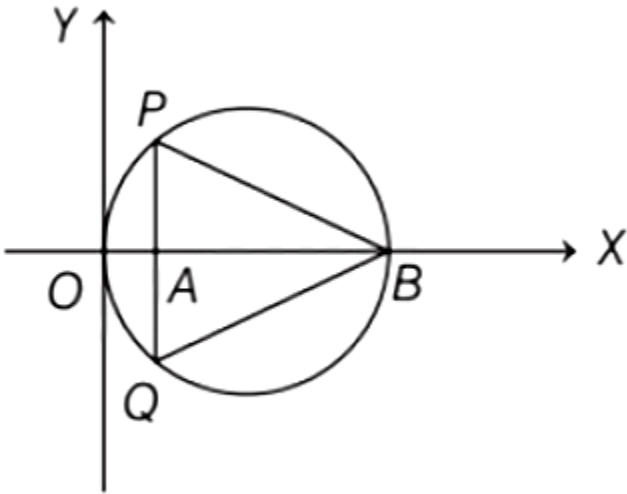

[2021, 26 Feb. Shift-I]

Options:

- A. $24\sqrt{2}$
- B. $24\sqrt{3}$
- C. $26\sqrt{3}$
- D. $26\sqrt{2}$

Answer: B

Solution:

Solution:

Given, $OA = 1$ unit, $OB = 13$ unit Since, OB is diameter of circle. Then, radius $(r) = \frac{13}{2} = 6.5$ unit

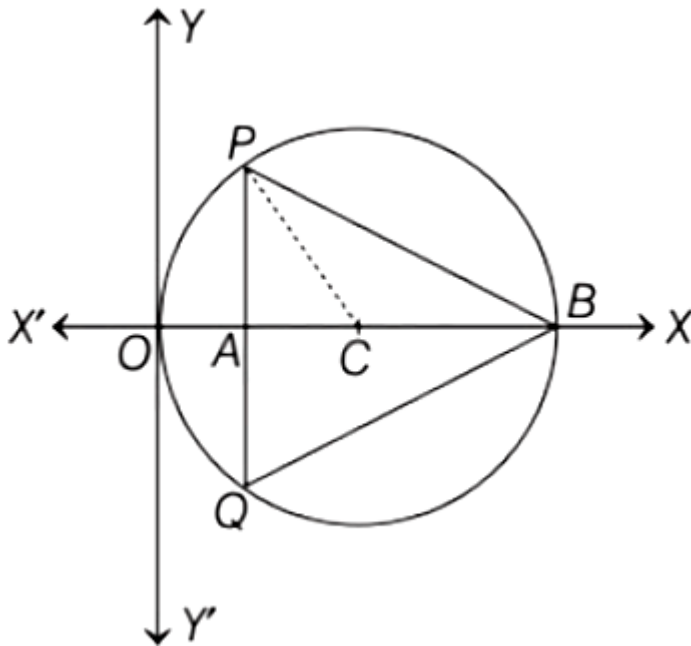

Draw a line joining points P and C , where C is the centre of the given circle. Then, $PC =$ radius of circle $= 6.5$ units $OC =$ radius of circle $= 6.5$ units
Now, $AC = OC - OA = 6.5 - 1 = 5.5$ units Then, using Pythagoras theorem,

$$\begin{aligned} (PA)^2 &= (PC)^2 - (AC)^2 \\ &= (6.5)^2 - (5.5)^2 \\ &= (6.5 - 5.5)(6.5 + 5.5) \\ &= (1)(12) = 12 \\ \therefore PA &= \sqrt{12} \end{aligned}$$

$$\text{Then, } PQ = 2PA = 2\sqrt{12}$$

$$\text{Hence, area of } \triangle PQB = \frac{1}{2} \times (\text{Base}) \times (\text{Height})$$

$$\begin{aligned} &= \frac{1}{2} \times (PQ) \times (AB) \\ &= \frac{1}{2} \times (PQ) \times (OB - OA) \\ &= \frac{1}{2} \times (2\sqrt{12}) \times (13 - 1) \\ &= 12\sqrt{12} = 24\sqrt{3} \text{ sq. units} \end{aligned}$$

Question207

A line is a common tangent to the circle $(x - 3)^2 + y^2 = 9$ and the parabola $y^2 = 4x$. If the two points of contact (a, b) and (c, d) are distinct and lie in the first quadrant, then $2(a + c)$ is equal to
[2021, 25 Feb. Shift-II]

Answer: 9

Solution:

Solution:

Given, circle $\Rightarrow (x-3)^2 + y^2 = 9$

Parabola $\Rightarrow y^2 = 4x$

Let equation of common tangent be

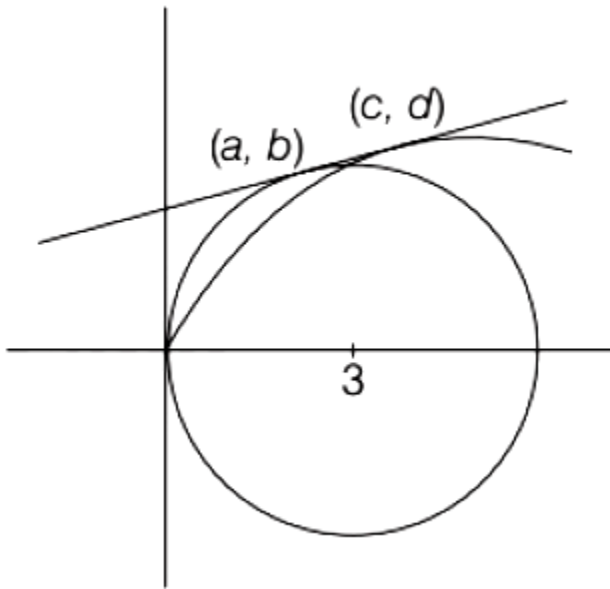

$$y = mx + \frac{a}{m}$$

$$\Rightarrow y = mx + \frac{1}{m} \quad (\because y^2 = 4x)$$

$$\Rightarrow m^2x - my + 1 = 0$$

The above line is tangent to circle.

\therefore Perpendicular from $(3, 0)$ to line = 3

$$\Rightarrow \left| \frac{(3m^2 - 0 + 1)}{\sqrt{m^2 + m^4}} \right| = 3$$

$$\Rightarrow (3m^2 + 1)^2 = 9(m^2 + m^4)$$

$$\Rightarrow m = \pm \frac{1}{\sqrt{3}}$$

$$\text{Tangent is } y = \frac{1}{\sqrt{3}}x + \sqrt{3}$$

$$\Rightarrow m = \frac{1}{\sqrt{3}}$$

$$\text{or } y = \frac{(-1)}{\sqrt{3}} \times (-\sqrt{3}) \text{ (rejected)}$$

For parabola, point of contact is



$$(c, d) = \left(\frac{a}{m^2}, \frac{2a}{n} \right)$$

$$\therefore (c, d) = (3, 2\sqrt{3})$$

Again, solve circle and line equation, we get

$$(x-3)^2 + \left[\left(\frac{1}{\sqrt{3}}x + \sqrt{3} \right) \right]^2 = 9$$

$$\Rightarrow x^2 + 9 - 6x + \frac{1}{3}x^2 + 3 + 2x = 9$$

$$\Rightarrow \frac{4}{3}x^2 - 4x + 3 = 0$$

$$\Rightarrow x = \frac{3}{2} = a$$

$$\therefore 2(a+c) = 2\left(\frac{3}{2} + 3 \right) = 9$$

Question208

A tangent is drawn to the parabola $y^2 = 6x$, which is perpendicular to the line $2x + y = 1$. Which of the following points does not lie on it? [2021, 25 Feb. Shift-I]

Options:

A. $(-6, 0)$

B. $(4, 5)$

C. $(5, 4)$

D. $(0, 3)$

Answer: C

Solution:

Solution:

Given, parabola $\Rightarrow y^2 = 6x$

$$\Rightarrow y^2 = 4\left(\frac{3}{2}\right)x \quad [\because y^2 = 4ax]$$

and given, line $\Rightarrow 2x + y = 1$.

\therefore Equation of any tangent to the parabola having slope m is

$$y = mx + \frac{3}{2m} \quad [\because a = 3/2]$$

Slope of line $2x + y = 1$ is $m_1 = -2$

\therefore Tangent is perpendicular to this line,

$$\therefore \text{Slope of tangent} = m_2 = -\frac{1}{m_1} = \frac{1}{2}$$

\therefore Equation of tangent will be

$$y = \frac{1}{2}x + \frac{3}{2} \times 2$$

$$\Rightarrow y = \frac{x}{2} + 3$$

$$\text{or } 2y = x + 6$$

$$\text{or } x - 2y + 6 = 0$$

Clearly, on putting the coordinates of point $(5, 4)$, the equation of tangent is not satisfied

\therefore Point $(5, 4)$ does not lie on this tangent.

Question 209

If the curve $y = ax^2 + bx + c$, $x \in \mathbb{R}$, passes through the point $(1, 2)$ and the tangent line to this curve at origin is $y = x$, then the possible values of a, b, c are

[2021, 24 Feb. Shift-II]

Options:

A. $a = \frac{1}{2}, b = \frac{1}{2}, c = 1$

B. $a = 1, b = 0, c = 1$

C. $a = 1, b = 1, c = 0$

D. $a = -1, b = 1, c = 1$

Answer: C

Solution:

Solution:

Given, curve $\Rightarrow y = ax^2 + bx + c$, $x \in \mathbb{R}$ and point $(1, 2)$

\therefore The given curve passes through $(1, 2)$.

$$\therefore 2 = a + b + c$$

Also, slope of tangent of $y = ax^2 + bx + c$ is $\frac{dy}{dx} = 2ax + b$

\therefore Tangent passes through origin $(0, 0)$.

$$\therefore \left. \frac{dy}{dx} \right|_{(0,0)} = 2a \times 0 + b = b \quad \dots\dots\dots (i)$$

According to the question, tangent at origin is $y = x$

\therefore Its slope is 1. $\dots\dots\dots (ii)$

From Eqs. (i) and (ii),

$$b = 1$$

$$\text{Also, } a + b + c = 2$$

$$cc \Rightarrow a + c + 1 = 2$$

$$\Rightarrow a + c = 1$$

From the option look for $b = 1$ and $a + c = 1$

The only correct order triplet is $a = 1, b = 1, c = 0$.

Question210

If P is a point on the parabola $y = x^2 + 4$ which is closest to the straight line $y = 4x - 1$, then the coordinates of P are
[2021, 24 Feb. Shift-II]

Options:

A. (3, 13)

B. (1, 5)

C. (-2, 8)

D. (2, 8)

Answer: D

Solution:

Given, curve $y = x^2 + 4$

and, line $y = 4x - 1$

Here, $y = x^2 + 4$

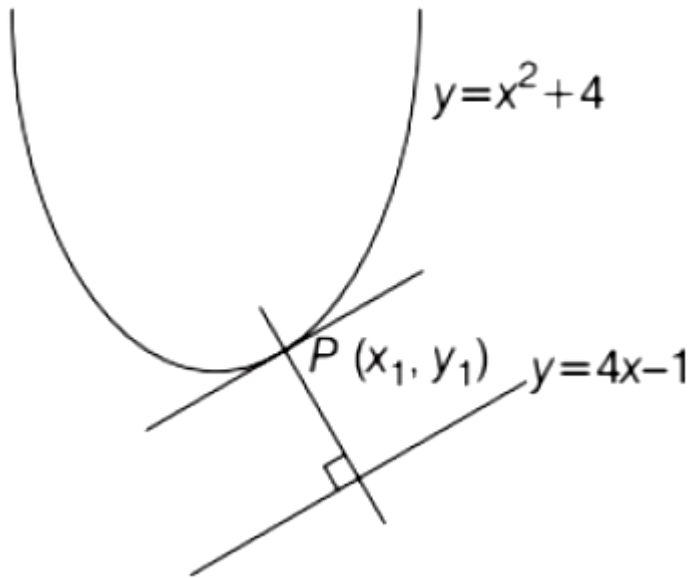

$$\therefore \frac{dy}{dx} = 2x \quad \dots\dots\dots (i)$$

and
 $y = 4x - 1$

$$\frac{dy}{dx} = 4 \quad \dots\dots\dots (ii)$$

Let the required point be $P(x_1, y_1)$.

$$\therefore \left. \frac{dy}{dx} \right|_P = 2x_1 \quad \dots\dots\dots (iii)$$

\therefore Slopes will be equal.

$$\therefore 2x_1 = 4 \quad [\text{from Eqs. (ii) and (iii)}]$$

$$\Rightarrow x_1 = \frac{4}{2} = 2$$

Now, the given point $P(x_1, y_1)$ lies on curve

$$y = x^2 + 4,$$

$$\therefore y_1 = x_1^2 + 4$$

$$\Rightarrow y_1 = 2^2 + 4 = 8$$

Hence, required coordinate of $P = (2, 8)$

Question211

A hyperbola passes through the foci of the ellipse $\frac{x^2}{25} + \frac{y^2}{16} = 1$ and its transverse and conjugate axes coincide with major and minor axes of the ellipse, respectively. If the product of their eccentricities is one, then the equation of the hyperbola is
[2021, 25 Feb. Shift-II]

Options:

A. $\frac{x^2}{9} - \frac{y^2}{16} = 1$

B. $\frac{x^2}{9} - \frac{y^2}{4} = 1$

C. $\frac{x^2}{9} - \frac{y^2}{25} = 1$

D. $x^2 - y^2 = 9$

Answer: A

Solution:

Solution:

Given, ellipse is $\frac{x^2}{25} + \frac{y^2}{16} = 1$

or $\frac{x^2}{(5)^2} + \frac{y^2}{(4)^2} = 1$

Compare it with standard equation $\frac{x^2}{a^2} + \frac{y^2}{b^2} = 1$,

we get $a = 5$, $b = 4$

Now, focus of ellipse = $(\pm c, 0)$ where

$$c = \sqrt{a^2 - b^2}$$

Put the values of a and b , we get

$$c = \sqrt{5^2 - 4^2} = \sqrt{25 - 16} = \sqrt{9}$$

\therefore Focus = $(\pm 3, 0)$

According to question, hyperbola passes through the focus of ellipse.

Let equation of hyperbola be $\frac{x^2}{a^2} - \frac{y^2}{b^2} = 1$

Since, it passes through $(\pm 3, 0)$, we get $\frac{(\pm 3)^2}{a^2} - \frac{0}{b^2} = 1$, gives $a = \pm 3$ or $a^2 = 9$

Also, given that product of eccentricities is 1.

Now, (Eccentricity of ellipse)

$$(\text{Eccentricity of hyperbola}) = 1 \Rightarrow \left(\sqrt{1 - \frac{16}{25}} \right) \left(\sqrt{1 + \frac{b^2}{9}} \right) = 1$$

(using formula of eccentricity of ellipse and hyperbola)

$$\Rightarrow \left(\sqrt{\frac{9}{25}} \right) \left(\sqrt{1 + \frac{b^2}{9}} \right) = 1$$

(using formula of eccentricity of ellipse and hyperbola)



$$\Rightarrow \left(\sqrt{\frac{9}{25}} \right) \left(\sqrt{1 + \frac{b^2}{9}} \right) = 1$$

Squaring on both sides,

$$1 + \frac{b^2}{9} = \frac{25}{9} \Rightarrow b^2 = 16$$

Thus, equation of hyperbola is

$$\frac{x^2}{9} - \frac{y^2}{16} = 1.$$

Question212

The locus of the point of intersection of the lines $(\sqrt{3})kx + ky - 4\sqrt{3} = 0$ and $\sqrt{3}x - y - 4(\sqrt{3})k = 0$ is a conic, whose eccentricity is [2021, 25 Feb. Shift-1]

Answer: 2

Solution:

Solution:

Given, lines are $\sqrt{3}kx + ky - 4\sqrt{3} = 0 \dots (i)$

$\sqrt{3}x - y - 4\sqrt{3}k = 0 \dots (ii)$

Multiply Eq. (ii) $\times k$ and then adding Eqs.

(i) and (ii),

$$\sqrt{3}kx + ky - 4\sqrt{3} = 0$$

$$\sqrt{3}kx - ky - 4\sqrt{3}k^2 = 0$$

$$(2\sqrt{3}x)k = 4\sqrt{3} + 4\sqrt{3}k^2$$

$$\therefore x = \frac{4\sqrt{3}(1+k^2)}{2\sqrt{3}k} = 2\left(k + \frac{1}{k}\right)$$

Subtracting Eq. (i) from Eq. (ii),

$$\sqrt{3}kx + ky - 4\sqrt{3} = 0$$

$$\sqrt{3}kx - ky - 4\sqrt{3}k^2 = 0$$

$$2ky = 4\sqrt{3} - 4\sqrt{3}k^2$$

$$y = \frac{4\sqrt{3}(1-k^2)}{2k} = 2\sqrt{3}\left(k - \frac{1}{k}\right)$$

We have, $x = 2\left(k + \frac{1}{k}\right)$ and

$$cy = 2\sqrt{3}\left(\frac{1}{k} - k\right)$$

$$\frac{x}{2} = \left(k + \frac{1}{k}\right) \dots\dots\dots \text{(iii)}$$

$$\frac{y}{2\sqrt{3}} = \left(\frac{1}{k} - k\right) \dots\dots\dots \text{(iv)}$$

Squaring and subtracting Eq. (iii) from Eq. (iv),

$$\frac{x^2}{4} - \frac{y^2}{12} = \left(k^2 + \frac{1}{k^2} + 2\right) - \left(\frac{1}{k^2} + k^2 - 2\right)$$

$$\frac{x^2}{4} - \frac{y^2}{12} = 4$$

$$\text{or } \frac{x^2}{16} - \frac{y^2}{48} = 1$$

Clearly, this is a hyperbol(a)

$$\therefore e^2 = 1 + \frac{b^2}{a^2} = 1 + \frac{48}{16} = 1 + 3$$

$$e^2 = 4$$

$$\therefore e = \sqrt{4} = 2 (\because e \text{ is positive})$$

Question213

The locus of the mid-point of the line segment joining the focus of the parabola $y^2 = 4ax$ to a moving point of the parabola, is another parabola whose directrix is :

24 Feb 2021 Shift 1

Options:

A. $x = -\frac{a}{2}$

B. $x = \frac{a}{2}$

C. $x = 0$

D. $x = a$

Answer: C

Solution:

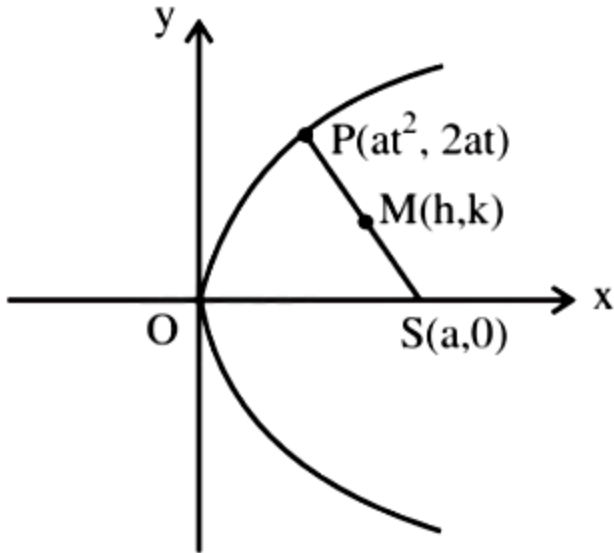

$$h = \frac{at^2 + a}{2}, k = \frac{2at + 0}{2}$$

$$\Rightarrow t^2 = \frac{2h - a}{a} \text{ and } t = \frac{k}{a}$$

$$\Rightarrow \frac{k^2}{a^2} = \frac{2h - a}{a}$$

$$\Rightarrow \text{Locus of } (h, k) \text{ is } y^2 = a(2x - a)$$

$$\Rightarrow y^2 = 2a \left(x - \frac{a}{2} \right)$$

$$\text{Its directrix is } x - \frac{a}{2} = -\frac{a}{2} \Rightarrow x = 0$$

Question214

If one of the diameters of the circle $x^2 + y^2 - 2x - 6y + 6 = 0$ is a chord of another circle 'C', whose center is at (2, 1), then its radius is
24 Feb 2021 Shift 1

Answer: 3

Solution:

Solution:

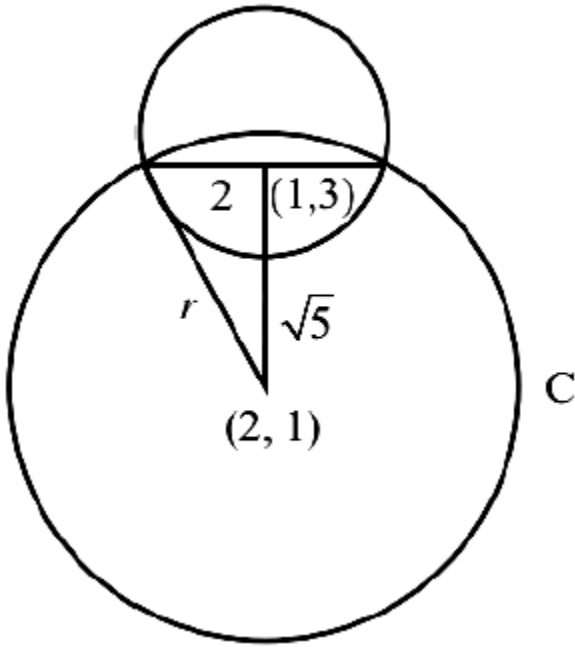

Given that $\hat{x}^2 + \hat{y}^2 - 2x - 6y + 6 = 0$ center $(1, 3)$ and radius $= 2$

Distance between $(1, 3)$ and $(2, 1)$ is $\sqrt{5}$

$$\therefore (\sqrt{5})^2 + (2)^2 = r^2$$

Question 215

If the curves, $\frac{x^2}{a} + \frac{y^2}{b} = 1$ and $\frac{x^2}{c} + \frac{y^2}{d} = 1$, intersect each other at an angle of 90° , then which of the following relations is true?
[2021, 25 Feb. Shift-I]

Options:

A. $a + b = c + d$

B. $a - b = c - d$

C. $a - c = b + d$

D. $ab = \frac{c+d}{a+b}$

Answer: B

Solution:

Solution:

Given, curves $\frac{x^2}{a} + \frac{y^2}{b} = 1$ and $\frac{x^2}{c} + \frac{y^2}{d} = 1 \therefore \frac{x^2}{a} + \frac{y^2}{b} = 1$

On differentiating both sides w.r.t. x , we get

$$\frac{2x}{a} + \frac{2y}{b} \cdot \frac{dy}{dx} = 0$$

$$\therefore \frac{dy}{dx} = \frac{-bx}{ay} \dots\dots\dots (i)$$

Also, $\frac{x^2}{c} + \frac{y^2}{d} = 1$

On differentiating both sides w.r.t. x , we get

$$\frac{2x}{c} + \frac{2y}{d} \cdot \frac{dy}{dx} = 0$$

$$\therefore \frac{dy}{dx} = \frac{-dx}{cy} \dots\dots\dots (ii)$$

\therefore Both the curves intersect each other at 90° .

Question216

Choose the correct statement about two circles whose equations are given below.

$$x^2 + y^2 - 10x - 10y + 41 = 0$$

$$x^2 + y^2 - 22x - 10y + 137 = 0$$

[2021, 18 March Shift-1]

Options:

- A. circles have same centre
- B. circles have no meeting point
- C. circles have only one meeting point
- D. circles have two meeting points

Answer: C

Solution:

Given, equation of circles

$$x^2 + y^2 - 10x - 10y + 41 = 0 \quad \dots\dots\dots (i)$$

$$x^2 + y^2 - 22x - 10y + 137 = 0 \quad \dots\dots\dots (ii)$$

Centre (C_1) and radius (r_1) of Eq. (i) are

$$C_1 = (5, 5) \text{ and } r_1 = 3$$

and centre (C_2) and radius (r_2) of Eq. (ii) are

$$C_2 = (11, 5) \text{ and } r_2 = 3$$

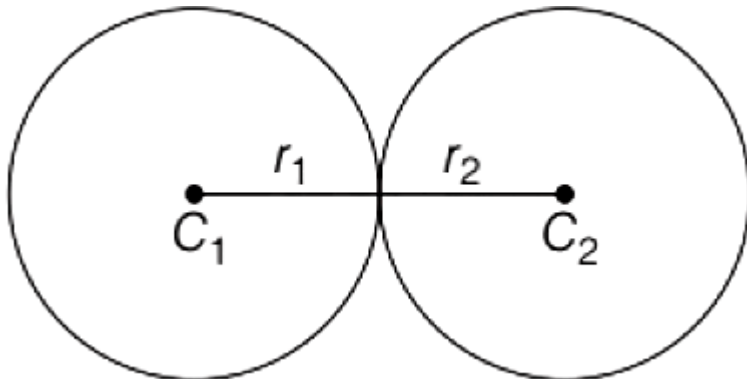

We observe that,

$$C_1C_2 = \text{distance between centres}$$

$$= (11 - 5)^2 + (5 - 5)^2 = 6 = r_1 + r_2$$

\therefore Circles Eqs. (i) and (ii) touch each other externally.

Hence, circles have only one meeting point.

Question217

For the four circles M, N, O and P_1 following four equations are given

Circle M : $x^2 + y^2 = 1$

Circle N : $x^2 + y^2 - 2x = 0$

Circle O : $x^2 + y^2 - 2x - 2y + 1 = 0$

Circle P : $x^2 + y^2 - 2y = 0$

If the centre of circle M is joined with centre of the circle N, further centre of circle N is joined with centre of the circle O, centre of circle O is joined with the centre of circle P and lastly, centre of circle P is joined with centre of circle M, then these lines form the sides of a
[2021, 18 March Shift-I]

Options:

- A. rhombus
- B. square
- C. rectangle
- D. parallelogram

Answer: B

Solution:

Solution:

Given, $M \Rightarrow x^2 + y^2 = 1$, its centre

$O_1 \equiv (0, 0)$

$N \Rightarrow x^2 + y^2 - 2x = 0$, its centre $O_2 \equiv (1, 0)$

$O \Rightarrow x^2 + y^2 - 2x - 2y + 1 = 0$, its centre

$O_3 \equiv (1, 1)$

$P \Rightarrow x^2 + y^2 - 2y = 0$, its centre $O_4 \equiv (0, 1)$

We see that,

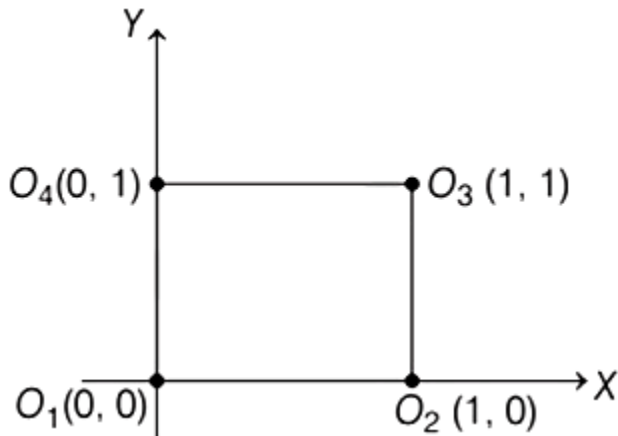

$O_1O_2 = O_2O_3 = O_3O_4 = O_4O_1$ and $O_1O_3 = O_2O_4$

Hence, $O_1O_2O_3O_4$ form a square.

Question 218

Let $S_1 \Rightarrow x^2 + y^2 = 9$ and $S_2 \Rightarrow (x - 2)^2 + y^2 = 1$. Then the locus of center of a variable circle S which touches S_1 internally and S_2 externally always passes through the points
[2021, 18 March Shift-II]

Options:

A. $(0, \pm\sqrt{3})$

B. $\left(\frac{1}{2}, \pm\frac{\sqrt{5}}{2}\right)$

C. $\left(2, \pm\frac{3}{2}\right)$

D. $(1, \pm 2)$

Answer: A

Solution:

Solution:

Given, $S_1 \Rightarrow x^2 + y^2 = 9$

$S_2 \Rightarrow (x-2)^2 + y^2 = 1$

$\therefore C_1 \equiv (0, 0)$ and $r_1 = 3$

$C_2 \equiv (2, 0), r_2 = 1$

Let centre of variable circle be $P(h, k)$ and radius be r .

From the given data, it is clear that given circles touch each other internally. Hence, variable circle touches S_1 internally and S_2 externally as shown in figure below.

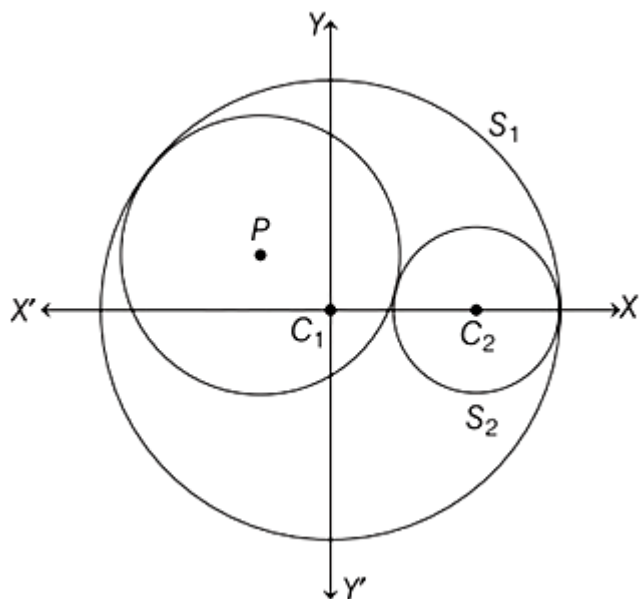

Clearly, $PC_1 = 3 - r$

and $PC_2 = 1 + r$

and $C_1C_2 = 2$

$\therefore PC_1 + PC_2 = 4$



which is greater than C_1C_2 .

Hence, locus of P is an ellipse whose foci are C_1 and C_2 and major axis is $2a = 4$.

and $2ae = C_1C_2 = 2$

$$\Rightarrow e = \frac{1}{2}$$

$$\Rightarrow b^2 = 4\left(1 - \frac{1}{4}\right) = 3$$

Centre is mid-point of $C_1(0, 0)$ and $C_2(2, 0)$.

\therefore Centre of ellipse is $(1, 0)$.

$$\frac{(x-1)^2}{4} + \frac{y^2}{3} = 1$$

is the equation of locus of centre of variable circle which is satisfied by $\left(2, \pm \frac{3}{2}\right)$.

Question219

Choose the incorrect statement about the two circles whose equations are given below $x^2 + y^2 - 10x - 10y + 41 = 0$ and

$$x^2 + y^2 - 16x - 10y + 80 = 0$$

[2021, 17 March Shift-1]

Options:

- A. Distance between two centres is the average of radii of both the circles.
- B. Both circles' centres lie inside region of one another.
- C. Both circles pass through the centre of each other.
- D. Circles have two intersection points.

Answer: B

Solution:

Solution:

$$C_1 \Rightarrow x^2 + y^2 - 10x - 10y + 41 = 0$$

$$(x-5)^2 + (y-5)^2 + 41 = 25 + 25$$

$$\Rightarrow \text{Centre} = (5, 5) \text{ and Radius} = 3$$

$$\Rightarrow (x-5)^2 + (y-5)^2 = 3^2$$

$$C_2 \Rightarrow x^2 + y^2 - 16x - 10y + 80 = 0$$

$$(x-8)^2 + (y-5)^2 + 80 = 64 + 25$$

$$\Rightarrow (x-8)^2 + (y-5)^2 = 3^2$$

\Rightarrow Centre = (8, 5) and Radius = 3

Now, distance between centres

$$= \sqrt{(8-5)^2 + (5-5)^2} = 3$$

$$\text{Average radii} = \frac{3+3}{2} = 3$$

\therefore Option (a) is correct.

$$C_1(8, 5) = (8-5)^2 + (5-5)^2 - 9 = 0$$

$$C_2(5, 5) = (5-8)^2 + (5-5)^2 - 9 = 0$$

Centres of each other lies on circumference of each other. Hence, (b) is incorrect statement.

Question220

The minimum distance between any two points P_1 and P_2 while considering point P_1 on one circle and point P_2 on the other circle for the given circles equations

$$x^2 + y^2 - 10x - 10y + 41 = 0$$

$$x^2 + y^2 - 24x - 10y + 160 = 0 \text{ is } \dots\dots\dots$$

[2021, 17 March Shift-1]

Answer: 1

Solution:

$$C_1 \Rightarrow x^2 + y^2 - 10x - 10y + 41 = 0$$

$$\Rightarrow (x-5)^2 + (y-5)^2 = 3^2$$

$$C_2 \Rightarrow x^2 + y^2 - 24x - 10y + 160 = 0$$

$$\Rightarrow (x-12)^2 + (y-5)^2 = 3^2$$

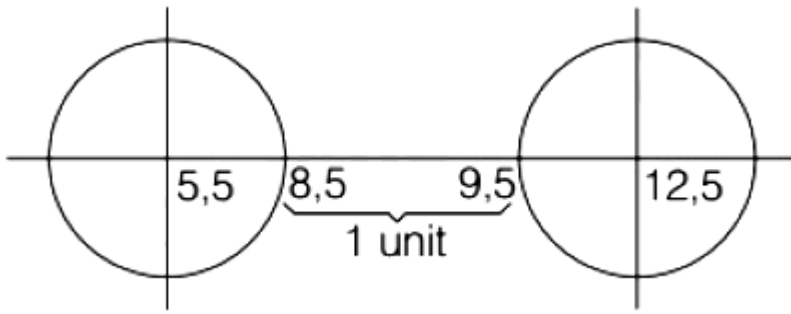

\therefore Minimum distance = 1 unit.

Question221

The line $2x - y + 1 = 0$ is a tangent to the circle at the point $(2, 5)$ and the centre of the circle lies on $x - 2y = 4$. Then, the radius of the circle is

[2021, 17 March Shift-I]

Options:

A. $3\sqrt{5}$

B. $5\sqrt{3}$

C. $5\sqrt{4}$

D. $4\sqrt{5}$

Answer: A

Solution:

Solution:

Given, $2x - y + 1 = 0$ is a tangent to the circle at $(2, 5)$

So, normal at $(2, 5)$ will be $\frac{(y-5)}{(x-2)} = \frac{-1}{2}$

$\Rightarrow 2y - 10 = -x + 2$

$\Rightarrow x + 2y = 12$

Now, it is also given that centre lies on $x - 2y = 4$.

So, coordinates of centre will be the solution of $\begin{cases} x + 2y = 12 \\ x - 2y = 4. \end{cases} \Rightarrow x = 8, y = 2$



Radius will be the distance between (8, 2) and (2, 5)

$$r^2 = (8-2)^2 + (2-5)^2$$

$$\Rightarrow r^2 = 36 + 9 \Rightarrow r = \sqrt{45} = 3\sqrt{5}$$

Question222

Let ABCD be a square of side of unit length. Let a circle C_1 centred at A with unit radius is drawn.

Another circle C_2 , which touches C_1 and the lines AD and AB are tangent to it, is also drawn. Let a tangent line from the point C to the circle C_2 meet the side AB at E. If the length of EB is $\alpha + \sqrt{3}\beta$, where α, β are integers, then $\alpha + \beta$ is equal to
[2021, 16 March Shift-1]

Answer: 1

Solution:

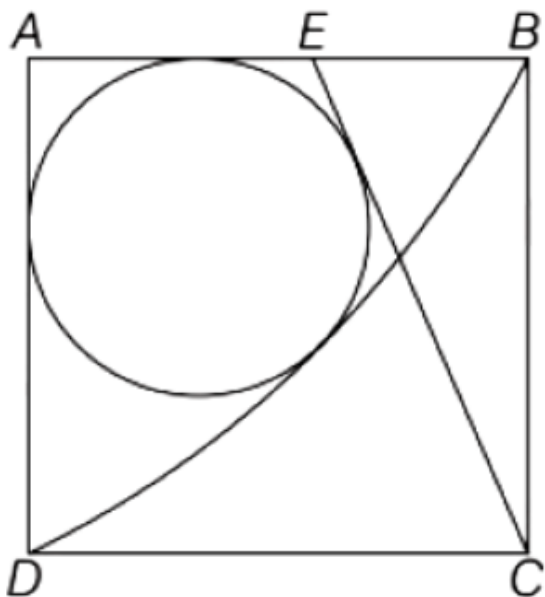

Given, $EB = \alpha + \sqrt{3}\beta$

Let O be the centre of circle C_2 .

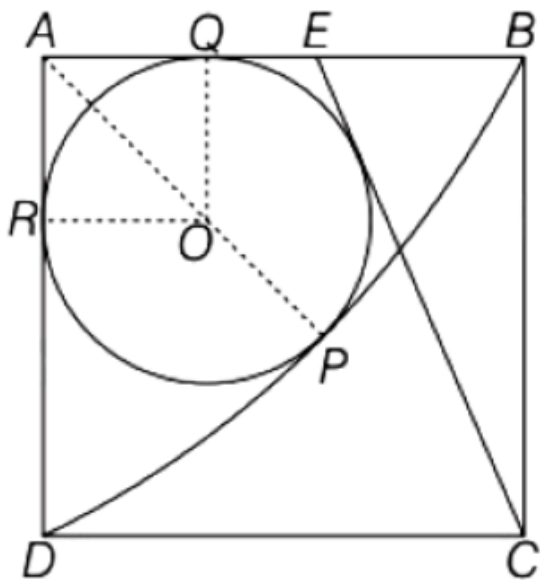

$$OQ^2 + OR^2 = AO^2$$

$$\Rightarrow AO + OP = AP = 1$$

$$\Rightarrow AO + r = 1$$

$$OQ^2 + OR^2 = AO^2$$

$$\Rightarrow r^2 + r^2 = (1-r)^2$$

$$\Rightarrow 2r^2 = r^2 + 1 - 2r$$

$$\Rightarrow r^2 + 2r + 1 = 1 + 1$$

$$\Rightarrow (r+1)^2 = 2$$

$$\Rightarrow r+1 = \sqrt{2} \Rightarrow r = \sqrt{2} - 1$$

As, $AO = 1 - r$

$$AC = \sqrt{2}$$

So, $OC = AC - AO$

$$= \sqrt{2} - (1 - \sqrt{2} + 1) = 2(\sqrt{2} - 1)$$

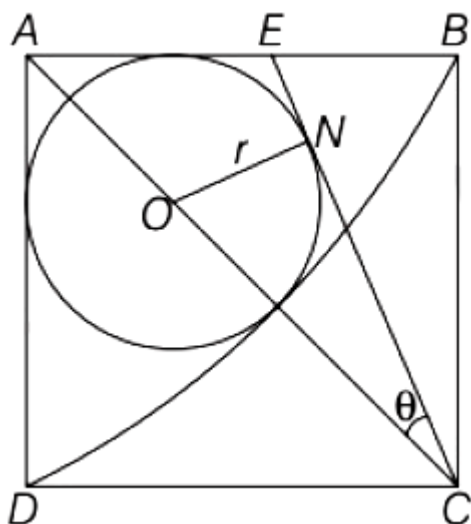

In $\triangle OCN$, we have

$$\frac{ON}{OC} = \sin \theta$$

$$\Rightarrow \frac{\sqrt{2}-1}{2(\sqrt{2}-1)} = \frac{1}{2} = \sin \theta \Rightarrow \theta = \pi/6$$

In $\triangle EBC$, we have

$$\frac{EB}{BC} = \tan 15^\circ$$

$$EB = (\tan 15^\circ)BC$$

$$= (\tan 15^\circ) [\because BC = 1 \text{ unit}]$$

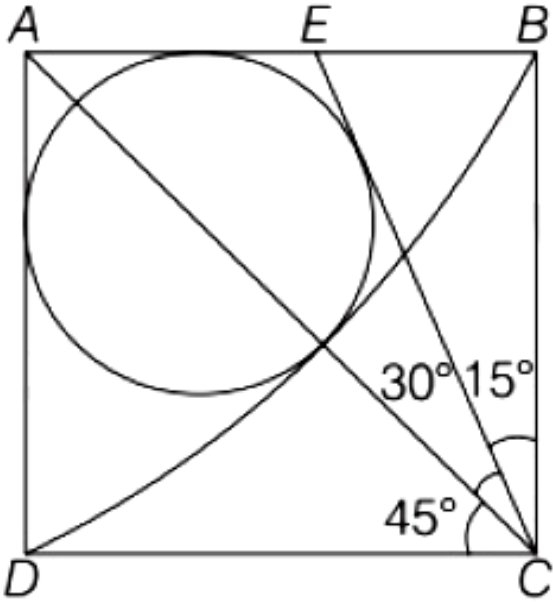

Now,

$$\tan 2\theta = \frac{2 \tan \theta}{1 - \tan^2 \theta}$$

$$\therefore \tan 30^\circ = \frac{2 \tan 15^\circ}{1 - \tan^2 15^\circ}$$

$$\Rightarrow 1 - \tan^2 15^\circ = 2\sqrt{3} \tan 15^\circ$$

$$\Rightarrow \tan^2 15^\circ + 2\sqrt{3} \tan 15^\circ - 1 = 0$$

$$\tan 15^\circ = \frac{-2\sqrt{3} \pm \sqrt{12+4}}{2}$$

$$\tan 15^\circ = -\sqrt{3} + 2$$

$$\therefore EB = 2 - \sqrt{3} = \alpha + \sqrt{3}\beta$$

$$\alpha = 2, \beta = -1$$
$$\therefore \alpha + \beta = 2 + (-1) = 1$$

Question223

Let the lengths of intercepts on X -axis and Y -axis made by the circle $x^2 + y^2 + ax + 2ay + c = 0$, ($a < 0$) be $2\sqrt{2}$ and $2\sqrt{5}$, respectively. Then, the shortest distance from origin to a tangent to this circle which is perpendicular to the line $x + 2y = 0$, is equal to [2021, 16 March Shift-11]

Options:

A. $\sqrt{11}$

B. $\sqrt{7}$

C. $\sqrt{6}$

D. $\sqrt{10}$

Answer: C

Solution:

Solution:

$$x^2 + y^2 + ax + 2ay + c = 0 (a < 0)$$

For a circle in standard form

$$x^2 + y^2 + 2gx + 2fy + c = 0$$

$$\text{x -intercept} = 2\sqrt{g^2 - c}$$

$$\text{y -intercept} = 2\sqrt{f^2 - c}$$

$$\text{Here, } 2g = a \Rightarrow g = a/2$$

$$c2f = 2a \Rightarrow f = a$$

$$\text{x-intercept} \Rightarrow 2\sqrt{\frac{a^2}{4} - c} = 2\sqrt{2}$$

$$\Rightarrow \frac{a^2}{4} - c = 2 \dots\dots\dots (i)$$

$$\text{y -intercept} \Rightarrow 2\sqrt{a^2 - c} = 2\sqrt{5}$$

$$a^2 - c = 5 \dots\dots\dots (ii)$$

Subtracting Eq. (ii) from Eq. (i), we get

$$c\left(\frac{3}{4}\right)a^2 = 3$$

$$\Rightarrow a^2 = 4 \Rightarrow a = \pm 2$$

As, $a < 0$, so, $a = -2$, $c = -1$

$$\text{So, } x^2 + y^2 - 2x - 4y - 1 = 0$$

$$(x-1)^2 + (y-2)^2 - 1 = 1 + 4$$

$$\Rightarrow (x-1)^2 + (y-2)^2 = 6$$

Centre $(1, 2)$, Radius $= \sqrt{6}$

Equation of tangent is perpendicular to $x + 2y = 0$.

So, equation of tangent will be

$$2x - y + \lambda = 0$$

Now, perpendicular distance of this line from $(1, 2)$ will be $\sqrt{6}$ units.

$$\frac{|2 \cdot 1 - 2 + \lambda|}{\sqrt{5}} = \sqrt{6}$$

$$\Rightarrow \lambda = \pm \sqrt{30}$$

$$\text{So, } T \Rightarrow 2x - y \pm \sqrt{30} = 0$$

Now, shortest distance from origin $(0, 0)$

to tangent T will be

$$\frac{|2 \cdot 0 - 0 \pm \sqrt{30}|}{\sqrt{2^2 + 1^2}} = \frac{\sqrt{30}}{\sqrt{5}} = \sqrt{6}$$

Question224

If the three normals drawn to the parabola, $y^2 = 2x$ pass through the point $(a, 0)$, $a \neq 0$, then a must be greater than [2021, 16 March Shift-1]

Options:

A. $\frac{1}{2}$

B. $-\frac{1}{2}$

C. -1

D. 1

Answer: D

Solution:

Given, equation of parabola $\Rightarrow y^2 = 2x$

Equation of normal of parabola, $y^2 = 4ax$ is $tx + y = 2at + at^3$

Here, $4a = 2$

So, $a = 1/2$

So, equation of normal $\Rightarrow tx + y = t + t^3/2$

$$t^3 + (2 - 2x)t - 2y = 0$$

As, there are three normals which are passing through $(a, 0)$, so there must be three roots of this equation.

$$t^3 + (2 - 2a)t - 2.0 = 0$$

$$\Rightarrow t^3 + (2 - 2a)t = 0$$

$$\therefore t_1 + t_2 + t_3 = -(2 - 2a) = 2a - 2$$

$$\text{and } t_1t_2 + t_2t_3 + t_3t_1 = 0$$

$$\text{So, } t_1^2 + t_2^2 + t_3^2 > 0$$

$$(t_1 + t_2 + t_3)^2 - 2(t_1t_2 + t_2t_3 + t_3t_1) > 0$$

$$\Rightarrow (2a - 2)^2 - 2.0 > 0$$

$$\Rightarrow a > 1$$

Question225

Let C be the locus of the mirror image of a point on the parabola $y^2 = 4x$ with respect to the line $y = x$. Then, the equation of tangent to C at $P(2, 1)$ is

[2021, 16 March Shift-II]

Options:

A. $x - y = 1$

B. $2x + y = 5$

C. $x + 3y = 5$

D. $x + 2y = 5$

Answer: A

Solution:

The mirror image of any point (α, β) with respect to line $y = x$ is simply (β, α) .

Let (h, k) be the mirror image of a point on parabola $y^2 = 4ax$

Then, (k, h) will be the mirror image of (h, k) and it will lie on parabola.

$$\text{So, } y^2 = 4x$$

$$\Rightarrow x^2 = 4y$$

Hence, Locus is $x^2 = 4y$ (i)

For finding equation of tangent differentiate Eq. (i) w.r.t. x

$$2x = 4 \frac{dy}{dx}$$

$$\Rightarrow \frac{dy}{dx} = \frac{2x}{4} = \left(\frac{x}{2} \right)$$

$$\Rightarrow \left(\frac{dy}{dx} \right)_{2,1} = \left(\frac{2}{2} \right) = 1$$

$$\Rightarrow \frac{y-1}{x-2} = 1 \Rightarrow y-1 = x-2$$

$$y = x - 1$$

\therefore Equation of tangent $\Rightarrow y = x - 1$

$$\Rightarrow x - y = 1$$

Question 226

Let a tangent be drawn to the ellipse $\frac{x^2}{27} + y^2 = 1$ at $(3\sqrt{3} \cos \theta, \sin \theta)$, where $\theta \in \left(0, \frac{\pi}{2} \right)$. Then the value of θ , such that the sum of intercepts on axes made by this tangent is minimum is equal to [2021, 18 March Shift-II]

Options:

A. $\frac{\pi}{8}$

B. $\frac{\pi}{4}$

C. $\frac{\pi}{6}$

D. $\frac{\pi}{3}$

Answer: C

Solution:

Solution:

Given, equation of ellipse is

$$\frac{x^2}{27} + y^2 = 1$$

Now, equation of tangent to the ellipse at $P(3\sqrt{3}\cos\theta, \sin\theta)$ is given by

$$\frac{3\sqrt{3}\cos\theta \cdot x}{27} + \sin\theta \cdot y = 1$$

$$\Rightarrow \frac{x\cos\theta}{3\sqrt{3}} + y\sin\theta = 1 \quad \dots\dots\dots (i)$$

X -intercept of Eq. (i) is

$$x = 3\sqrt{3}\sec\theta = OA \text{ (say)}$$

Y -intercept of Eq. (i) is

$$y = \operatorname{cosec}\theta = OB \text{ (say)}$$

\therefore Sum of intercepts

$$= 3\sqrt{3}\sec\theta + \operatorname{cosec}\theta = f(\theta) \text{ (say)}$$

$$\Rightarrow f'(\theta) = 3\sqrt{3}\sec\theta\tan\theta - \operatorname{cosec}\theta \cdot \cot\theta$$

Put

$$\Rightarrow \frac{3\sqrt{3}\sin\theta}{\cos^2\theta} = \frac{\cos\theta}{\sin^2\theta}$$

$$\Rightarrow \frac{\sin\theta}{\cos^2\theta} \cdot \frac{\sin^2\theta}{\cos^2\theta} = \frac{1}{3\sqrt{3}}$$

$$\Rightarrow \tan^3\theta = \frac{1}{3\sqrt{3}}$$

$$\Rightarrow \theta = \pi/6$$

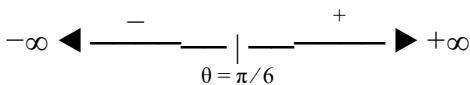

$\therefore f'(\theta)$ changes sign from negative to positive when moving from left to right

$\therefore f(\theta)$ will attain minima at $\theta = \frac{\pi}{6}$

Question227

Let L be a tangent line to the parabola $y^2 = 4x - 20$ at (6, 2). If L is also a tangent to the ellipse $\frac{x^2}{2} + \frac{y}{b} = 1$, then the value of b is equal to
[2021, 17 March Shift-II]

Options:

A. 11

B. 14

C. 16

D. 20

Answer: B

Solution:

Solution:

Given, equation of parabola is

$$y^2 = 4x - 20 \dots\dots (i)$$

Differentiating Eq. (i) w.r.t. x , we get

$$2y \frac{dy}{dx} = 4 \Rightarrow \frac{dy}{dx} = \frac{2}{y}$$

$\therefore \left(\frac{dy}{dx} \right)_{(6, 2)} =$ Slope of tangent at

$$(6, 2) = \frac{2}{2} = 1$$

\therefore Equation of tangent is

$$y - 2 = 1(x - 6) \Rightarrow x - y - 4 = 0 \dots\dots (ii)$$

As, we know the condition of tangency to the ellipse,

A straight line $y = mx + c$ will be tangent to the ellipse

$$\frac{x^2}{a^2} + \frac{y^2}{b^2} = 1 \text{ is}$$

$$c^2 = a^2 m^2 + b^2$$

$$\text{Then, } 16 = 2(1)^2 + b^2 \text{ [here, } c = 4, m = 1, b = \sqrt{b} \text{]}$$

$$b^2 = 14$$

Question228

A square ABCD has all its vertices on the curve $x^2 y^2 = 1$. The mid-points of its sides also lie on the same curve. Then, the square of area of ABCD is

[2021, 18 March Shift-I]

Answer: 80

Solution:

Solution:

Let $A\left(t_1, \frac{1}{t_1}\right)$ and $C\left(t_3, \frac{1}{t_3}\right)$ lies on $xy = 1$

and $B\left(t_2, \frac{1}{t_2}\right)$ and $D\left(t_4, \frac{1}{t_4}\right)$ lies on $xy = -1$

as shown in figure.

ABCD is a square and by symmetry, diagonals must intersect at $O(0, 0)$.

$$\angle AOB = 90^\circ$$

$$\Rightarrow \frac{-1}{t_1^2} \cdot \frac{1}{t_2^2} = -1$$

$$\Rightarrow t_1^2 t_2^2 = 1 \quad \dots\dots\dots (i)$$

Also, mid-point of AB is $P\left(\frac{t_1+t_2}{2}, \frac{t_2-t_1}{2t_1 t_2}\right)$

lies on $xy = 1$

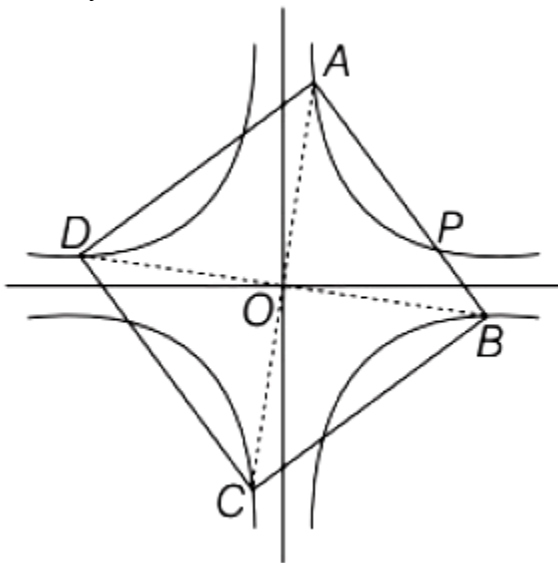

$$\Rightarrow \left(\frac{t_1+t_2}{2}\right) \left(\frac{t_2-t_1}{2t_1 t_2}\right) = 1$$

$$\Rightarrow t_2^2 - t_1^2 = 4t_1 t_2 \quad \dots\dots\dots (ii)$$

Now, area of square = $(AB)^2$

$$= (t_1 - t_2)^2 + \left(\frac{1}{t_1} - \frac{1}{t_2}\right)^2$$

$$= (t_1 - t_2)^2 + \frac{(t_2 + t_1)^2}{t_1^2 t_2^2}$$

$$= (t_1 - t_2)^2 + (t_2 + t_1)^2 \quad [\text{From Eq. (i)}]$$

$$= 2(t_1^2 + t_2^2)$$

$$= 2\sqrt{(t_2^2 - t_1^2)^2 + 4t_1^2 t_2^2}$$

$$= 2\sqrt{16t_1^2 t_2^2 + 4t_1^2 \cdot t_2^2}$$

$$= 2\sqrt{20} = \sqrt{80}$$

∴ Square of area = 80 sq units

Question229

Consider a hyperbola $H : x^2 - 2y^2 = 4$. Let the tangent at a point $P(4, \sqrt{6})$ meet the x-axis at Q and latus rectum at $R(x_1, y_1)$, $x_1 > 0$. If F is a focus of H which is nearer to the point P , then the area of $\triangle QFR$ is equal to

[2021, 18 March Shift-II]

Options:

- A. $4\sqrt{6}$
- B. $\sqrt{6} - 1$
- C. $\frac{7}{\sqrt{6}} - 2$
- D. $4\sqrt{6} - 2$

Answer: C

Solution:

Solution:

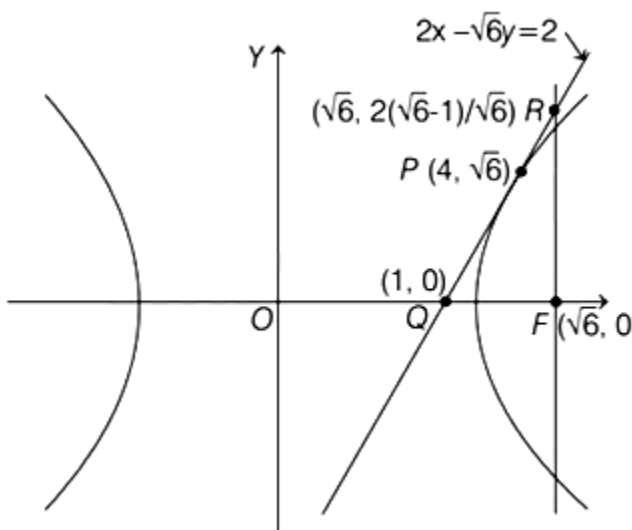

Given, $x^2 - 2y^2 = 4$

$$\Rightarrow \frac{x^2}{4} - \frac{y^2}{2} = 1$$

$$\Rightarrow \frac{x^2}{(2)^2} - \frac{y^2}{(\sqrt{2})^2} = 1$$

Here, $a = 2, b = \sqrt{2}$

$$\begin{aligned} \therefore e &= \sqrt{1 + \frac{b^2}{a^2}} = \sqrt{1 + \frac{2}{4}} \\ &= \sqrt{1 + \frac{1}{2}} = \sqrt{\frac{3}{2}} \end{aligned}$$

So, Focus (F) = $(\pm ae, 0) = (\pm\sqrt{6}, 0)$

Now, equation of tangent at P(4, $\sqrt{6}$) is

$$4x - 2\sqrt{6}y = 4 \quad [\because x \cdot x - 2 \cdot y \cdot y = 4, x \cdot 4 - 2 \cdot y \cdot \sqrt{6} = 4]$$

$$\Rightarrow 2x - \sqrt{6}y = 2 \quad \dots\dots\dots (i)$$

Putting $y = 0$ in Eq. (i), we get x-intercept of tangent i.e. $x = 1$

$$\therefore Q \equiv (1, 0)$$

Hence, equation of corresponding latus rectum is $x = \sqrt{6}$.

$$\therefore R \equiv \left(\sqrt{6}, \frac{2(\sqrt{6}-1)}{\sqrt{6}} \right)$$

$$\left[\text{putting } x = \sqrt{6} \text{ in Eq. (i), we get } y = \frac{2(\sqrt{6}-1)}{\sqrt{6}} \right]$$

$$\begin{aligned} \therefore \text{Area of } \triangle OFR &= \frac{1}{2} \times (QF) \times (RF) \\ &= \frac{1}{2}(\sqrt{6}-1) \times \frac{2(\sqrt{6}-1)}{\sqrt{6}} \\ &= \frac{(\sqrt{6}-1)^2}{\sqrt{6}} = \left(\frac{7}{\sqrt{6}} - 2 \right) \end{aligned}$$

Question230

The locus of the mid-points of the chord of the circle, $x^2 + y^2 = 25$ which is tangent to the hyperbola, $\frac{x^2}{9} - \frac{y^2}{16} = 1$ is [2021, 16 March Shift-1]

Options:

A. $(x^2 + y^2)^2 - 16x^2 + 9y^2 = 0$

B. $(x^2 + y^2)^2 - 9x^2 + 144y^2 = 0$

$$C. (x^2 + y^2)^2 - 9x^2 - 16y^2 = 0$$

$$D. (x^2 + y^2)^2 - 9x^2 + 16y^2 = 0$$

Answer: D

Solution:

Solution:

Given, equation of circle $\Rightarrow x^2 + y^2 = 25$

Equation of hyperbola $\Rightarrow \frac{x^2}{9} - \frac{y^2}{16} = 1$

Let the mid-point of the chord of the circle be (h, k) .

The equation of a chord through its mid-point is simply $T = S_1$

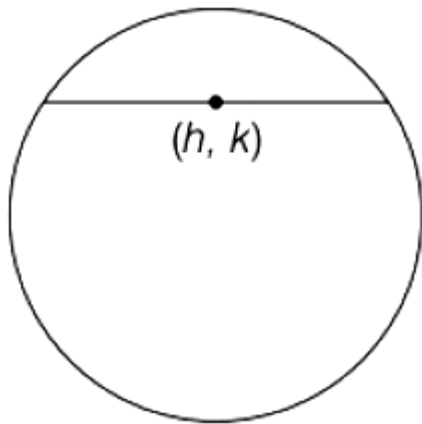

where T is the equation of tangent and S_1 is the value of S by putting (h, k) .

Here,

$$hx + ky = h^2 + k^2$$

The equation of tangent to hyperbola $\frac{x^2}{a^2} - \frac{y^2}{b^2} = 1$ is $y = mx \pm \sqrt{a^2m^2 - b^2}$

Here, $y = mx \pm \sqrt{9m^2 - 16}$

$$\text{So, } y = \frac{-hx}{k} + \frac{h^2 + k^2}{k} \dots\dots\dots (i)$$

$$\text{and } y = mx \pm \sqrt{9m^2 - 16} \dots\dots\dots (ii)$$

Eqs. (i) and (ii) are identical, so

$$\frac{1}{1} = \frac{-h/k}{m} = \frac{h^2 + k^2}{k\sqrt{9m^2 - 16}} \Rightarrow m = \frac{-h}{k}$$

$$\Rightarrow 9m^2 - 16 = \frac{(h^2 + k^2)^2}{k^2}$$

$$\Rightarrow 9\left(\frac{h^2}{k^2}\right) - 16 = \frac{(h^2 + k^2)^2}{k^2}$$

$$\Rightarrow 9h^2 - 16k^2 = (h^2 + k^2)^2 \begin{cases} h \rightarrow x \\ k \rightarrow y. \end{cases}$$

$$\text{So, } 9x^2 - 16y^2 = (x^2 + y^2)^2$$

$$\text{or } (x^2 + y^2) - 9x^2 + 16y^2 = 0$$

Question231

Two tangents are drawn from the point $P(-1, 1)$ to the circle $x^2 + y^2 - 2x - 6y + 6 = 0$. If these tangents touch the circle at points A and B , and if D is a point on the circle such that length of the segments AB and AD are equal, then the area of the $\triangle ABD$ is equal to [2021, 27 July Shift-I]

Options:

- A. 2
- B. $(3\sqrt{2} + 2)$
- C. 4
- D. $3(\sqrt{2} - 1)$

Answer: C

Solution:

Solution:

$$C : x^2 + y^2 - 2x - 6y + 6 = 0$$

$$(x - 1)^2 + (y - 3)^2 = 2^2$$

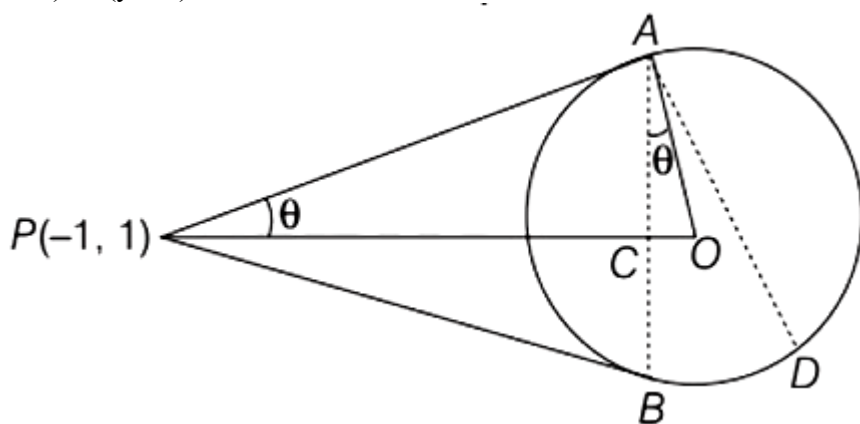

$$AP = \text{Length of tangent} = \sqrt{S_1}$$

$$\Rightarrow AP^2 = (-1 - 1)^2 + (1 - 3)^2 - 4$$

$$\Rightarrow AP^2 = 4 + 4 - 4$$

$$\therefore AP = 2$$

$$\tan \theta = \frac{AO}{AP} = \frac{2}{2} = 1 \quad (\therefore \theta = 45^\circ)$$

In $\triangle ACO$,

$$\frac{AC}{AO} = \cos \theta$$

$$\therefore AC = 2 \times \frac{1}{\sqrt{2}} = \sqrt{2}$$

$$\therefore \triangle OAC \cong \triangle OAM$$

$$\triangle OAC \cong \triangle OBC$$

$$\triangle OBC \cong \triangle ODM$$

$$\therefore \text{Area of } \triangle ABD = 4 \text{ Area of } \triangle ACO$$

$$= 4 \times \frac{1}{2} (AO \times AC \times \sin \theta)$$

$$= 2 \times 2 \times \sqrt{2} \times \frac{1}{\sqrt{2}} = 4$$

Question232

Let P and Q be two distinct points on a circle which has center at C(2, 3) and which passes through origin O. If OC is perpendicular to both the line segments CP and CQ, then the set {P, Q} is equal to [2021, 27 July Shift-1]

Options:

A. $\{(4, 0), (0, 6)\}$

B. $\{(2 + 2\sqrt{2}, 3 - \sqrt{3}), (2 - 2\sqrt{2}, 3 + \sqrt{5})\}$

C. $\{(2 + 2\sqrt{2}, 3 + \sqrt{5}), (2 - 2\sqrt{2}, 3 - \sqrt{5})\}$

D. $\{(-1, 5), (5, 1)\}$

Answer: D

Solution:

Solution:

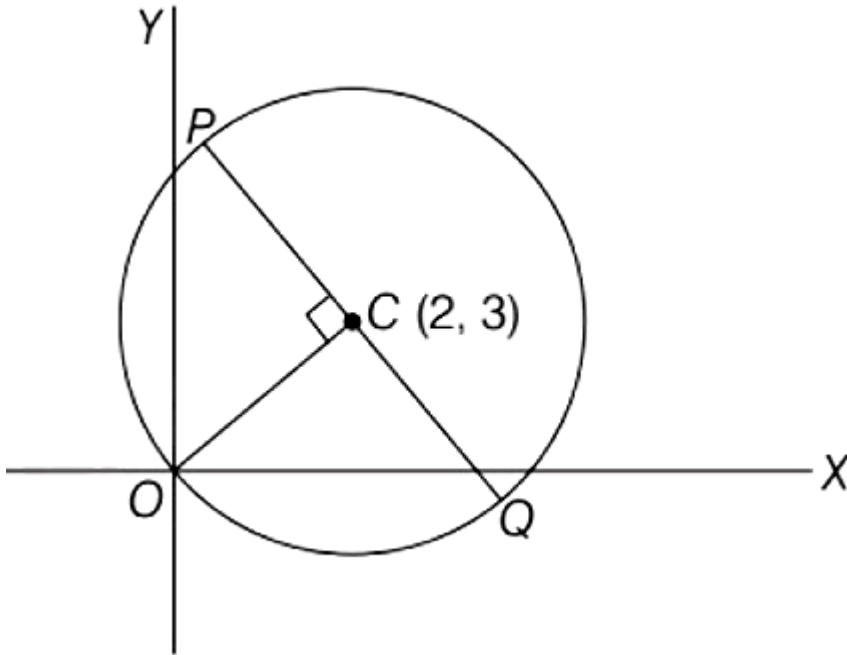

Equation of circle is

$$(x - 2)^2 + (y - 3)^2 = (2 - 0)^2 + (3 - 0)^2$$

$$\Rightarrow (x - 2)^2 + (y - 3)^2 = 13$$

$$\text{Slope of OC} = \frac{3 - 0}{2 - 0} = \frac{3}{2}$$

$$\therefore \text{Slope of PQ} = -\frac{2}{3} = \tan \theta$$

Points at a distance of $\sqrt{13}$ units from O
with slope $= -\frac{2}{3}$

$$\text{Using, } \begin{cases} x_2 = x_1 \pm r \cos \theta \\ y_2 = y_1 \pm r \sin \theta. \end{cases}$$

$$\text{So, } x_2 = 2 \pm \sqrt{13} \left(\frac{3}{\sqrt{13}} \right) = 2 \pm 3$$

$$\therefore x_2 : \{5, -1\}$$

$$y_2 : 3 \pm \sqrt{13} \left(\frac{-2}{\sqrt{13}} \right) = 3 \pm (-2)$$

Question233

Let $A = \{ (x, y) \in \mathbb{R} \times \mathbb{R} \mid$

$$2x^2 + 2y^2 - 2x - 2y = 1 \},$$

$B = \{ (x, y) \in \mathbb{R} \times \mathbb{R} \mid$

$$4x^2 + 4y^2 - 16y + 7 = 0 \}$$

$$C = \{ (x, y) \in \mathbb{R} \times \mathbb{R} \mid x^2 + y^2 - 4x - 2y + 5 \leq r^2 \}$$

Then the minimum value of $|r|$ such that $A \cup B \subseteq C$ is equal to
[2021, 27 July Shift-1]

Options:

A. $\frac{3 + \sqrt{10}}{2}$

B. $\frac{2 + \sqrt{10}}{2}$

C. $\frac{3 + 2\sqrt{5}}{2}$

D. $1 + \sqrt{5}$

Answer: C

Solution:

Solution:

$$A \Rightarrow 2x^2 + 2y^2 - 2x - 2y = 1$$

$$\Rightarrow 2(x^2 - x) + 2(y^2 - y) = 1$$

$$\Rightarrow 2\left(x^2 - x + \frac{1}{4} - \frac{1}{4}\right)$$

$$+ 2\left(y^2 - y + \frac{1}{4} - \frac{1}{4}\right) = 1$$

$$\Rightarrow 2\left(x - \frac{1}{2}\right)^2 - \frac{1}{2} + 2\left(y - \frac{1}{2}\right)^2 - \frac{1}{2} = 1$$

$$\Rightarrow \left(x - \frac{1}{2}\right)^2 + \left(y - \frac{1}{2}\right)^2 = 1$$

Here, $C_1 = \left(\frac{1}{2}, \frac{1}{2}\right)$ and $r_1 = 1$

$$\Rightarrow 4x^2 + 4y^2 - 16y + 7 = 0$$

$$\Rightarrow 4(y^2 - 4y + 4 - 4) + 4x^2 + 7 = 0$$

$$\Rightarrow 4(y - 2)^2 + 4x^2 + 7 - 16 = 0$$

$$\Rightarrow x^2 + (y - 2)^2 = \frac{9}{4}$$

Here $C_2 = (0, 2)$ and $r_2 = \frac{3}{2}$

$$C \Rightarrow x^2 + y^2 - 4x - 2y + 5 \leq r^2$$

$$(x-2)^2 + (y-1)^2 \leq r^2$$

Here, $C_3 = (2, 1)$

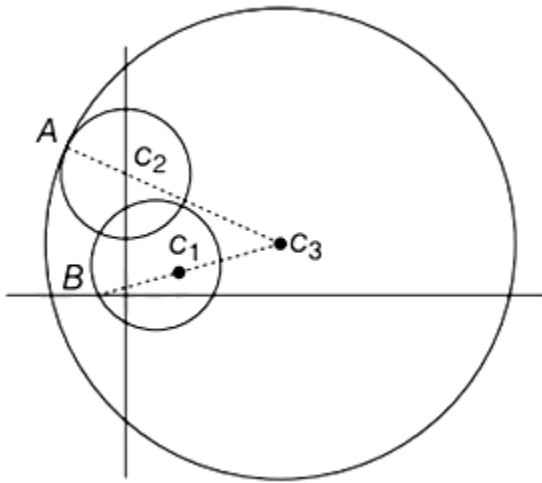

$$\begin{aligned} \text{At } (2, 1) \text{ circle of B, } S_B &= 2^2 + (1-2)^2 - \frac{9}{4} \\ &= 4 + 1 - \frac{9}{4} = \frac{11}{4} > 0 \\ C_1 C_2 &= \sqrt{\frac{1}{4} + \frac{9}{4}} = \sqrt{\frac{5}{2}} \\ C_2 C_3 &= \sqrt{4+1} = \sqrt{5} \\ C_1 C_3 &= \sqrt{\frac{9}{4} + \frac{1}{4}} = \sqrt{\frac{5}{2}} \\ r_3 &\geq C_2 C_3 + r_2 \text{ [}\because C_2 C_3 > C_1 C_2 \text{ and } C_1 C_3\text{]} \\ |r| &\geq \sqrt{5} + \frac{3}{2} \Rightarrow |r| \geq \frac{3+2\sqrt{5}}{2} \end{aligned}$$

Question234

Consider a circle C which touches the Y -axis at (0, 6) and cuts off an intercept $6\sqrt{5}$ on the X -axis. Then the radius of the circle C is equal to [2021, 27 July Shift-II]

Options:

- A. $\sqrt{53}$
- B. 9
- C. 8

D. $\sqrt{82}$

Answer: B

Solution:

Solution:

Let a circle C which touches the Y -axis at $(0, 6)$ and cuts off an intercept $6\sqrt{5}$ on the X -axis.

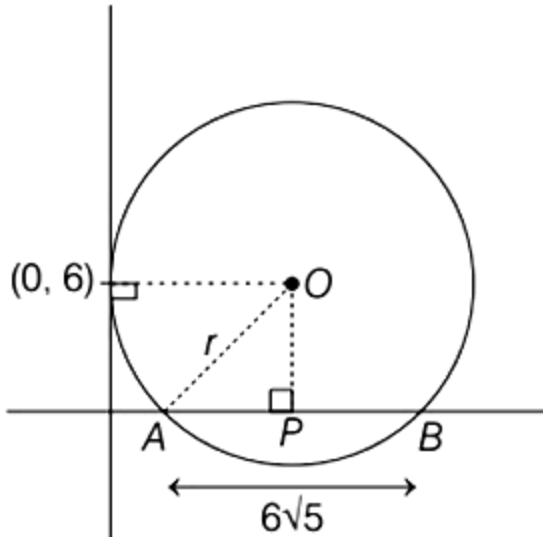

Chord $AB = 6\sqrt{5}$

So, $AP = 3\sqrt{5}$ (perpendicular from centre bisects the chord)

and $OP = 6$

In $\triangle APO$, $r^2 = 6^2 + (3\sqrt{5})^2 = 36 + 45$

$\Rightarrow r^2 = 81 \Rightarrow r = 9$

Question235

Let the circle

$$S : 36x^2 + 36y^2 - 108x + 120y + C = 0$$

be such that it neither intersects nor touches the coordinate axes. If the point of intersection of the lines $x - 2y = 4$ and $2x - y = 5$ lies inside the circle S , then

[2021, 22 July Shift-II]

Options:

A. $\frac{25}{9} < C < \frac{13}{3}$

B. $100 < C < 165$

C. $81 < C < 156$

D. $100 < C < 156$

Answer: D

Solution:

Solution:

$$S \Rightarrow 36x^2 + 36y^2 - 108x + 120y + C = 0$$

$$x^2 + y^2 - 3x + \left(\frac{10}{3}\right)y + \frac{C}{36} = 0$$

$$\left(x - \frac{3}{2}\right)^2 + \left(y + \frac{5}{3}\right)^2 + \frac{C}{36} - \frac{9}{4} - \frac{25}{9} = 0$$

When $x = 0$,

$$36y^2 + 120y + C = 0$$

Since, it neither touch the coordinate axis nor intersects. So, the roots of this equation must be imaginary.

$$cc \Rightarrow D < 0$$

$$\Rightarrow 120^2 - 4.36C < 0$$

$$\Rightarrow C > \frac{120 \times 120}{4 \times 36}$$

$$C > 100 \dots\dots (i)$$

Similarly, when

$$y = 0, 36x^2 - 108x + C = 0$$

$$108^2 - 4.36C < 0$$

$$\Rightarrow C > 81 \dots\dots (ii)$$

From Eqs. (i) and (ii),

$$\Rightarrow C > 100$$

and point of intersection of $\begin{cases} x - 2y = 4 \\ 2x - y = 5. \end{cases}$ is $(2, -1)$.

So, $S_{(2, -1)} < 0$

$$\left(\frac{1}{2}\right)^2 + \left(\frac{2}{3}\right)^2 + \frac{C}{36} - \frac{9}{4} - \frac{25}{9} < 0$$

$$c < 156$$

$$C \in (100, 156)$$

Question236

Let r_1 and r_2 be the radii of the largest and smallest circles, respectively, which pass through the point $(-4, 1)$ and having their centres on the circumference of the circle $x^2 + y^2 + 2x + 4y - 4 = 0$. If

$$\frac{r_1}{r_2} = a + b\sqrt{2}, \text{ then } a + b \text{ is equal to}$$

[2021, 20 July Shift-II]

Options:

A. 3

B. 11

C. 5

D. 7

Answer: C

Solution:

Solution:

$$\text{Given, circle } \Rightarrow x^2 + y^2 + 2x + 4y - 4 = 0$$

$$\Rightarrow (x^2 + 2x + 1) + (y^2 + 4y + 4)$$

$$-1 - 4 - 4 = 0$$

$$\Rightarrow (x + 1)^2 + (y + 2)^2 = 9$$

Any point on the given circle be

$$[(3 \cos \theta - 1), (3 \sin \theta - 2)]$$

[to find the point coordinates, take $x + 1 = 3 \cos \theta$ and $y + 2 = 3 \sin \theta$]

Now, circle passes through $(-4, 1)$ and their centres lie on the given circle.

So, the centre coordinate of that circle be $(3 \cos \theta - 1, 3 \sin \theta - 2)$. Since, it passes through $(-4, 1)$, then radius of this circle be

$$r = \sqrt{(3 \cos \theta - 1 + 4)^2 + (3 \sin \theta - 2 - 1)^2}$$

$$= \sqrt{9 \cos^2 \theta + 9 + 18 \cos \theta + 9 \sin^2 \theta + 9 - 18 \sin \theta}$$

$$= \sqrt{27 + 18(\cos \theta - \sin \theta)}$$

$$= 3\sqrt{3 + 2(\cos \theta - \sin \theta)}$$

Maximum radius will be when $(\cos \theta - \sin \theta)$ is maximum i.e.

$$\cos \theta - \sin \theta = \frac{1}{\sqrt{2}} - \left(-\frac{1}{\sqrt{2}}\right) = \frac{2}{\sqrt{2}} = \sqrt{2}$$

$$\therefore r_1 = r_{\max} = 3\sqrt{3 + 2/\sqrt{2}}$$

Minimum radius will be when

$(\cos \theta - \sin \theta)$ is minimum i.e. $-\sqrt{2}$.

$$\therefore r_2 = r_{\min} = 3\sqrt{3-2\sqrt{2}}$$

$$\text{Given, } \frac{r_1}{r_2} = a + b\sqrt{2}, \text{ then } \frac{r_1^2}{r_2^2} = (a + b\sqrt{2})^2$$

$$\Rightarrow \frac{9(3+2\sqrt{2})}{g(3-2\sqrt{2})} = (a + b\sqrt{2})^2$$

$$\Rightarrow \frac{(3+2\sqrt{2})(3+2\sqrt{2})}{(3-2\sqrt{2})(3+2\sqrt{2})} = (a + b\sqrt{2})^2$$

$$\Rightarrow \frac{(3+2\sqrt{2})^2}{1} = (a + b\sqrt{2})^2$$

Comparing coefficients, $a = 3, b = 2$

$$\therefore a + b = 5$$

Question237

Let a parabola P be such that its vertex and focus lie on the positive X-axis at a distance

2 and 4 units from the origin, respectively. If tangents are drawn from O(0, 0) to the parabola P which meet P at S and R, then the area (in sq. units) of $\triangle SOR$ is equal to

[2021, 25 July Shift-I]

Options:

A. $16\sqrt{2}$

B. 16

C. 32

D. $8\sqrt{2}$

Answer: B

Solution:

Solution:

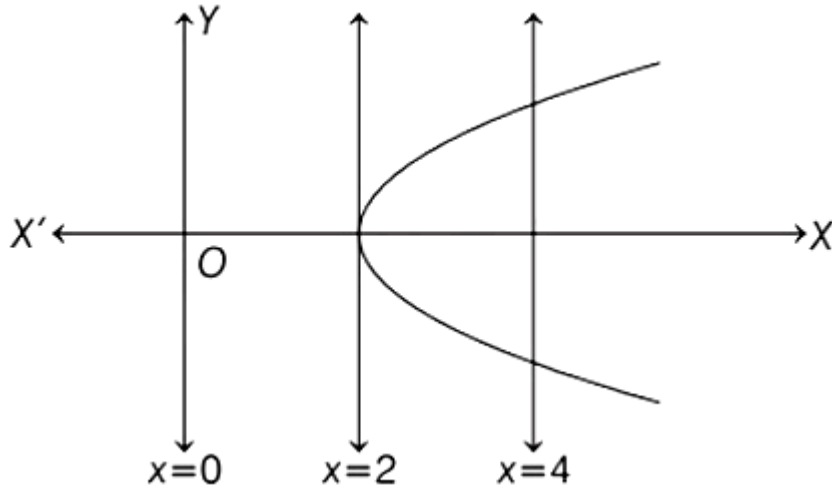

Equation of parabola $\Rightarrow y^2 = 4a(x - 2)$

$a = 2$

So, $y^2 = 8(x - 2)$

Equation of tangent

$\Rightarrow y = m(x - 2) + \frac{2}{m}$

It passes through $(0, 0)$,

$0 = -2m + \frac{2}{m}$

$\Rightarrow m^2 = 1 \Rightarrow m = \pm 1$

Equation $\Rightarrow y = \pm(x - 2) \pm 2$

$y = x$ or $y = -x$

If $y = x$

cc $\Rightarrow x^2 = 8(x - 2)$

$\Rightarrow x^2 - 8x + 16 = 0$

$\Rightarrow (x - 4)^2 = 0 \Rightarrow x = 4$

$y = \pm 4$

So, points are $(4, 4)$, $(4, -4)$ and $(0, 0)$.

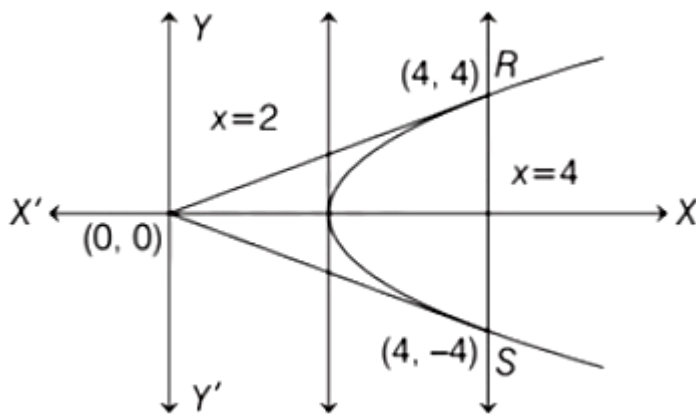

$\therefore \text{Area} = \left(\frac{1}{2} \times 4 \times 4 \right) \times 2 = 16 \text{ sq units}$

Question238

The equation of a circle is $\text{Re}(z^2) + 2[\text{Im}(z)]^2 + 2\text{Re}(z) = 0$ where, $z = x + iy$. A line which passes through the center of the given circle and the vertex of the parabola, $x^2 - 6x - y + 13 = 0$, has y-intercept equal to

.....

[2021, 25 July Shift-II]

Answer: 1

Solution:

Solution:

The equation of circle

$\text{Re}(z^2) + 2[\text{Im}(z)]^2 + 2\text{Re}(z) = 0$, where $z = x + iy$

$$cc \Rightarrow (x^2 - y^2) + 2y^2 + 2x = 0$$

$$\Rightarrow [\because z^2 = (x^2 - y^2) + 2xyi]$$

$$\Rightarrow x^2 + y^2 + 2x = 0$$

$$(x + 1)^2 + y^2 = 1$$

Centre = $(-1, 0)$

Now, parabola $\Rightarrow x^2 - 6x - y + 13 = 0$

$$\Rightarrow x^2 - 6x + 9 = y - 4$$

$$\Rightarrow (x - 3)^2 = y - 4$$

Vertex =

Equation of line passing through centre $(-1, 0)$ and vertex $(3, 4)$ is

$$y - 0 = \frac{4 - 0}{3 + 1}(x + 1) \Rightarrow y = x + 1$$

On comparing, $y = mx + c$

$$\Rightarrow \text{y-intercept} = 1$$

Question239

Let the tangent to the parabola $S : y^2 = 2x$ at the point $P(2, 2)$ meet the X-axis at Q and normal at it meet the parabola S at the point R . Then, the area (in square units) of $\triangle PQR$ is equal to

[2021, 20 July Shift-1]

Options:

A. $\frac{25}{2}$

B. $\frac{35}{2}$

C. $\frac{15}{2}$

D. 25

Answer: A

Solution:

Solution:

$$y^2 = 2x$$

At (2, 2), equation of tangent

$$\Rightarrow y(2) = (x + 2)$$

$$T_i \Rightarrow 2y = x + 2$$

Normal at (2, 2) $\Rightarrow y - 2 = -2(x - 2)$

$$N_i \Rightarrow y = -2x + 6$$

R is point of intersection of T and line $y = 0$

$$R(-2, 0)$$

$$(2, 2) = \left(\frac{t^2}{2}, t \right) \Leftrightarrow t = 2$$

If normal at t_1 meets the parabola again at t_2 ,

$$t_2 = -t_1 - \frac{2}{t_1}$$

$$-t_2 = -2 - \frac{2}{2} = -3$$

$$\therefore t_2 = 3$$

$$R : (at_2^2, 2at_2) \Rightarrow \left(\frac{1}{2} \cdot 9, 2 \cdot \frac{1}{2} \cdot 3 \right) \Rightarrow \left(\frac{9}{2}, 3 \right)$$

$$\therefore P(2, 2), Q(-2, 1), R\left(\frac{9}{2}, 3\right)$$

$$\text{Area} = \frac{1}{2} \begin{vmatrix} 1 & 1 & 1 \\ 2 & -2 & \frac{9}{2} \\ 2 & 1 & 3 \end{vmatrix}$$

$$\Rightarrow \text{Area} = \frac{25}{2}$$

Question240

Let $y = mx + c$, $m > 0$ be the focal chord of $y^2 = -64x$, which is tangent to $(x + 10)^2 + y^2 = 4$. Then, the value of $4\sqrt{2}(m + c)$ is equal to [2021, 20 July Shift-1]

Answer: 34

Solution:

Solution:

Equation of circle $\Rightarrow (x + 10)^2 + y^2 = 4$ Equation of tangent to circle

$x^2 + y^2 = a^2$ is $y = mx \pm a\sqrt{1 + m^2}$

Here, equation of tangent

$$y = m(x + 10) \pm 2\sqrt{1 + m^2}$$

$$\Rightarrow y = mx + 10m \pm 2\sqrt{1 + m^2}$$

On comparing this equation with $y = mx + c$, we get

$$c = 10m \pm 2\sqrt{1 + m^2} \dots\dots\dots (i)$$

This equation is also a focal chord of $y^2 = -64x$ whose focus is at $(-16, 0)$. So, it must pass through $(-16, 0)$.

$$y = mx + c$$

$$\Rightarrow 0 = -16m + c$$

$$\therefore c = 16m \dots\dots\dots (ii)$$

From Eqs. (i) and (ii),

$$16m = 10m \pm 2\sqrt{1 + m^2}$$

$$\Rightarrow 6m = \pm 2\sqrt{1 + m^2}$$

$$\Rightarrow 9m^2 = 1 + m^2$$

$$\Rightarrow m = \frac{1}{2\sqrt{2}} \text{ (as } m > 0)$$

$$\therefore c = 16m = 16 \cdot \left(\frac{1}{2\sqrt{2}}\right) = 4\sqrt{2}$$

$$\text{So, } 4\sqrt{2}(m + c) = 4\sqrt{2} \left(\frac{1}{2\sqrt{2}} + 4\sqrt{2}\right)$$

$$= 2 + 32 = 34$$

Question241

Let P be a variable point on the parabola $y = 4x^2 + 1$. Then, the locus of the mid point of the point P and the foot of the perpendicular drawn from the point P to the line $y = x$ is
[2021, 20 July Shift-II]

Options:

A. $(3x - y)^2 + (x - 3y) + 2 = 0$

B. $2(3x - y)^2 + (x - 3y) + 2 = 0$

C. $(3x - y)^2 + 2(x - 3y) + 2 = 0$

D. $2(x - 3y)^2 + (3x - y) + 2 = 0$

Answer: B

Solution:

Solution:

Given, parabola $y = 4x^2 + 1$

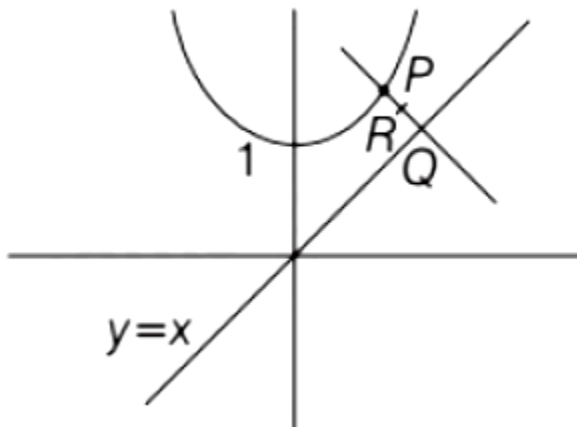

Let $R(a, b)$ be mid-point of line joining point P and Q where PQ is perpendicular to line $y = x$.

Let coordinates of P be $P(x, y)$, $Q(q, q)$ and $R(a, b)$ then, $a = \frac{x+q}{2}$ and $b = \frac{y+q}{2}$

Now, slope of line $y = x$ is $m_1 = 1$

Slope of line PO be

$$\frac{b-q}{a-q} = m_2 \text{ (say)}$$

\because Line $y = x$ and PQ are perpendicular to each other,

$$m_1 \cdot m_2 = -1$$

$$\Rightarrow \frac{b-q}{a-q} = -1 \Rightarrow b - q = q - a$$

$$\Rightarrow q = \frac{b+a}{2}$$

$$\therefore a = \frac{x+q}{2}$$

$$= \frac{x + \left(\frac{b+a}{2}\right)}{2} = \frac{2x+b+a}{4}$$

$$\Rightarrow x = \frac{4a-b-a}{2} = \frac{3a-b}{2} \text{ and } b = \frac{y+q}{2} = \frac{y + \left(\frac{b+a}{2}\right)}{2} = \frac{2y+b+a}{4}$$

$$\Rightarrow y = \frac{3b-a}{2}$$

Put (x, y) in equation of parabola as P(x, y) is variable point on parabola

$$\frac{3b-a}{2} = 4 \left(\frac{3a-b}{2} \right)^2 + 1$$

$$\frac{(3b-a)}{2} = (3a-b)^2 + 1$$

$$\Rightarrow (3b-a) = 2(3a-b)^2 + 2$$

Replace (a, b) as (x, y)

$$\Rightarrow (3y-x) = 2(3x-y)^2 + 2$$

$$\text{or } 2(3x-y)^2 + (x-3y) + 2 = 0$$

Question 242

A ray of light through (2, 1) is reflected at a point P on the Y-axis and then passes through the point (5, 3). If this reflected ray is the directrix of an ellipse with eccentricity $\frac{1}{3}$ and the distance of the nearer focus from this directrix is $\frac{8}{\sqrt{53}}$, then the equation of the other directrix can be

[2021, 27 July Shift-1]

Options:

A. $11x + 7y + 8 = 0$ or $11x + 7y - 15 = 0$

B. $11x - 7y - 8 = 0$ or $11x + 7y + 15 = 0$

C. $2x - 7y + 29 = 0$ or $2x - 7y - 7 = 0$

D. $2x - 7y - 39 = 0$ or $2x - 7y - 7 = 0$

Answer: C

Solution:

Solution:

Equation of the reflected ray will be

$$L \Rightarrow \frac{y-3}{x-5} = m$$

Now, the image of (2, 1) w.r.t. line $x = 0$ should lie on the reflected line.

Image of (2, 1) = (-2, 1)

$$\text{So, } \frac{1-3}{-2-5} = m \Rightarrow m = \frac{2}{7}$$

$$\text{So, equation of reflected ray } \Rightarrow \frac{y-3}{x-5} = \frac{2}{7}$$

$$c7y - 21 = 2x - 10$$

$$\Rightarrow 2x - 7y + 11 = 0 \text{ (equation of directrix)}$$

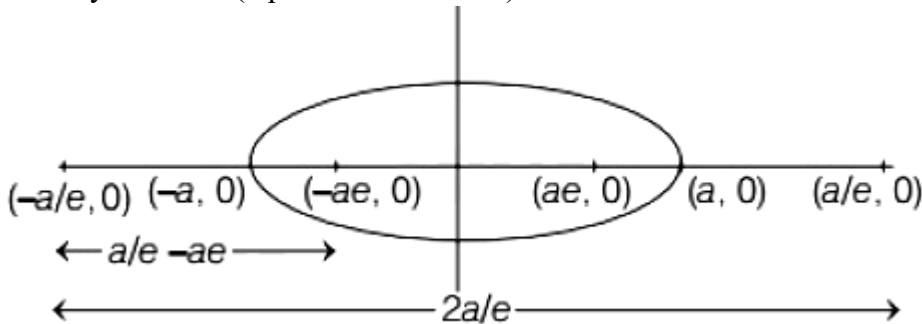

$$\text{Now, } e = \frac{1}{3} \text{ (given)}$$

$$\text{So, } \frac{a}{e} - ae = \frac{a}{1/3} - \frac{1}{3}a = \frac{8a}{3}$$

$$\Rightarrow \frac{8a}{3} = \frac{8}{\sqrt{53}} \text{ (given)}$$

$$\text{So, } a = \frac{3}{\sqrt{53}}$$

$$\text{and } \frac{2a}{e} = \left(2 \cdot \frac{3}{\sqrt{53}}\right) \times \left(\frac{3}{1}\right) = \frac{18}{\sqrt{53}}$$

Now, another directrix will be parallel to the first directrix and lie at a distance of $\frac{18}{\sqrt{53}}$ units.

So, let the equation of another directrix be $2x - 7y + \lambda = 0$

$$\text{Accordingly, } \frac{|\lambda - 11|}{\sqrt{2^2 + 7^2}} = \frac{18}{\sqrt{53}}$$

$$\Rightarrow |\lambda - 11| = 18$$

$$\Rightarrow \lambda = 11 \pm 18$$

$$\Rightarrow \lambda = 29 \text{ or } -7$$

So, equation of another directrix will be

$$2x - 7y + 29 = 0 \text{ or } 2x - 7y - 7 = 0$$

Question243

Let E be an ellipse whose axes are parallel to the co-ordinates axes, having its center at $(3, -4)$, one focus at $(4, -4)$ and one vertex at $(5, -4)$. If $mx - y = 4$, $m > 0$ is a tangent to the ellipse E , then the value of $5m^2$ is equal to
 [2021, 27 July Shift-II]

Answer: 3

Solution:

Solution:

E be an ellipse whose centre $C(3, -4)$ and focus $F(4, -4)$ and one vertex $A(5, -4)$.

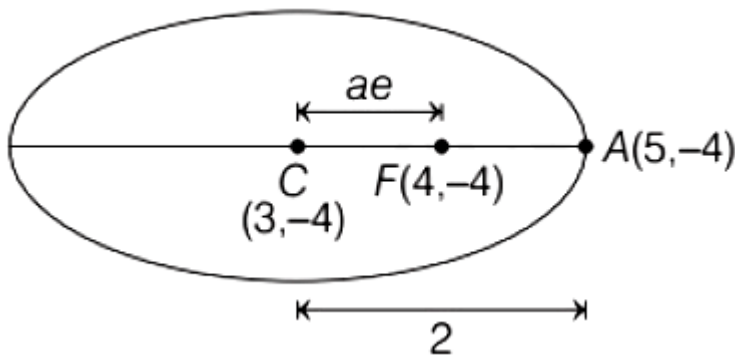

Hence, $a = 2$ and $ae = 1$

$$\Rightarrow e = \frac{1}{2}$$

$$\text{Now, } b^2 = a^2 - (ae)^2 = 4 - 1$$

$$b^2 = 3$$

So, equation of ellipse

$$E \Rightarrow \frac{(x-3)^2}{4} + \frac{(y+4)^2}{3} = 1$$

Intersecting with given tangent

$$mx - y = 4$$

$$\Rightarrow y + 4 = mx$$

$$\frac{x^2 - 6x + 9}{4} + \frac{m^2x^2}{3} = 1$$

$$\Rightarrow (3 + 4m^2)x^2 - 18x + 15 = 0$$

Now, $D = 0$

$$1r \Rightarrow 324 - 4(3 + 4m^2)(15) = 0$$

$$\Rightarrow 144 - 240m^2 = 0$$

$$\Rightarrow 5m^2 = 3$$

Question244

Let an ellipse $E \Rightarrow \frac{x^2}{a^2} + \frac{y^2}{b^2} = 1$, $a^2 > b^2$, passes through $\left(\sqrt{\frac{3}{2}}, 1\right)$ and has eccentricity $\frac{1}{\sqrt{3}}$. If a circle, centered at focus $F(\alpha, 0)$, $\alpha > 0$, of E and radius $\frac{2}{\sqrt{3}}$, intersects E at two points P and Q , then PQ^2 is equal to
[2021, 25 July Shift-1]

Options:

- A. $\frac{8}{3}$
- B. $\frac{4}{3}$
- C. $\frac{16}{3}$
- D. 3

Answer: C

Solution:

Solution:

$$E \Rightarrow \frac{x^2}{a^2} + \frac{y^2}{b^2} = 1 \text{ is passes through } \left(\sqrt{\frac{3}{2}}, 1\right)$$

$$\therefore \frac{3}{2a^2} + \frac{1}{b^2} = 1$$

$$a^2 - b^2 = a^2 e^2$$

$$\Rightarrow a^2 - b^2 = \frac{a^2}{3}$$

$$\Rightarrow 3a^2 - 3b^2 = a^2$$

$$\Rightarrow 2a^2 = 3b^2$$

$$\frac{3}{3b^2} + \frac{1}{b^2} = 1$$

$$\Rightarrow 2 = b^2$$

$$\Rightarrow a^2 = 3$$

$$\text{Focus } \left(\sqrt{3} \cdot \frac{1}{\sqrt{3}}, 0\right)$$

$$\Rightarrow \text{Focus} = (1, 0)$$

$$\text{Centre} = (1, 0), \text{Radius} = \frac{2}{\sqrt{3}}$$

$$(x-1)^2 + (y-0)^2 = \left(\frac{2}{\sqrt{3}}\right)^2 \dots\dots\dots (i)$$

$$E \Rightarrow \frac{x^2}{3} + \frac{y^2}{2} = 1 \dots\dots\dots (ii)$$

From Eqs. (i) and (ii)

$$x = 1, y = \pm \frac{2}{\sqrt{3}}$$

$$PO = \frac{4}{\sqrt{3}}$$

$$PQ^2 = \frac{16}{3}$$

Question245

If a tangent to the ellipse $x^2 + 4y^2 = 4$ meets the tangents at the extremities of its major axis at B and C, then the circle with BC as diameter passes through the point [2021, 25 July Shift-II]

Options:

A. $(\sqrt{3}, 0)$

B. $(\sqrt{2}, 0)$

C. $(1, 1)$

D. $(-1, 1)$

Answer: A

Solution:

Solution:

Equation of ellipse $\Rightarrow x^2 + 4y^2 = 4$

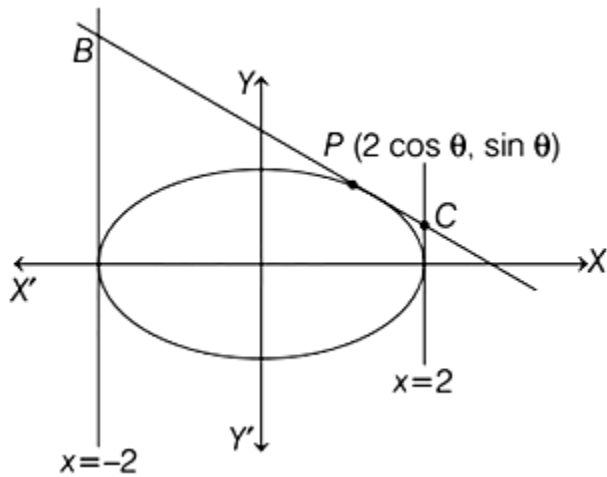

$$\Rightarrow \frac{x^2}{4} + \frac{y^2}{1} = 1$$

Extremities end of major axis = $(\pm 2, 0)$

Let any point P on ellipse $(2 \cos \theta, \sin \theta)$.

Equation of tangent to the ellipse at the point P is $\frac{2 \cos \theta x}{4} + \frac{y \sin \theta}{1} = 1$

Coordinate of B $(-2, \cot \frac{\theta}{2})$ and C $(2, \tan \frac{\theta}{2})$.

Equation of circle whose end points of diameter are B and C is

$$(x - 2)(x + 2) + \left(y - \cot \frac{\theta}{2}\right) \left(y - \tan \frac{\theta}{2}\right) = 0$$

$$\Rightarrow x^2 + y^2 - \left(\tan \frac{\theta}{2} + \cot \frac{\theta}{2}\right)y - 3 = 0$$

At $y = 0, x = \pm\sqrt{3}$

Hence, circle is passing through the point $(\pm\sqrt{3}, 0)$.

Question 246

Let $E_1 : \frac{x^2}{a^2} + \frac{y^2}{b^2} = 1, a > b$. Let E_2 be another ellipse such that it touches the end points of major axis of E_1 and the foci of E_2 are the end points of minor axis of E_1 . If E_1 and E_2 have same eccentricities, then its value is
[2021, 22 July Shift-II]

Options:

A. $\frac{-1+\sqrt{5}}{2}$

B. $\frac{-1+\sqrt{8}}{2}$

C. $\frac{-1+\sqrt{3}}{2}$

D. $\frac{-1+\sqrt{6}}{2}$

Answer: A

Solution:

$$e^2 = 1 - \frac{b^2}{a^2}$$

$$e^2 = 1 - \frac{a^2}{c^2}$$

$$\Rightarrow \frac{b^2}{a^2} = \frac{a^2}{c^2} \Rightarrow c = \frac{a^2}{b}$$

$$\text{Also, } b = ce \Rightarrow c = \frac{b}{e}$$

$$\Rightarrow \frac{b}{e} = \frac{a^2}{b}$$

$$\Rightarrow e = \frac{b^2}{a^2} = 1 - e^2$$

$$\Rightarrow e^2 + e - 1 = 0 \Rightarrow e = \frac{-1+\sqrt{5}}{2}$$

Question247

Let T be the tangent to the ellipse $E : x^2 + 4y^2 = 5$ at the point $P(1, 1)$.

If the area of the region bounded by the tangent T , ellipse E , lines

$x = 1$ and $x = \sqrt{5}$ is $\alpha\sqrt{5} + \beta + \gamma\cos^{-1}\left(\frac{1}{\sqrt{5}}\right)$, then $|\alpha + \beta + \gamma|$ is equal to

.....

[2021, 20 July, Shift-1]

Answer: 1.25

Solution:

Solution:

$$x^2 + 4y^2 = 5$$

At (1, 1), equation of tangent

$$\Rightarrow x \cdot 1 + 4y \cdot 1 = 5$$

$$\Rightarrow x + 4y = 5$$

$\therefore A : (1, 1)$

$$D : \left(\sqrt{5}, \frac{5 - \sqrt{5}}{4} \right)$$

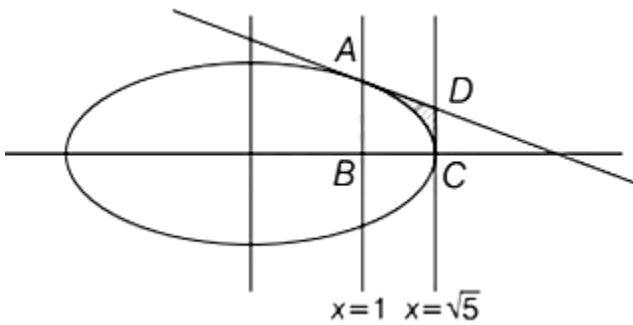

Area of shaded region

$$\begin{aligned} &= \int_1^{\sqrt{5}} \left(\frac{5-x}{4} - \frac{1}{2} \sqrt{5-x^2} \right) dx \\ &= \left[\frac{1}{4} \left(5x - \frac{x^2}{2} \right) - \frac{x}{4} \sqrt{5-x^2} - \frac{5}{4} \sin^{-1} \frac{x}{\sqrt{5}} \right]_1^{\sqrt{5}} \\ &= \frac{1}{4} \left[5\sqrt{5} - \frac{5}{2} - 0 - \frac{5\pi}{2} - 5 + \frac{1}{2} + 2 + 5 \sin^{-1} \frac{1}{\sqrt{5}} \right] \\ &= \frac{1}{4} \left[5\sqrt{5} - 5 - 5 \left(\frac{\pi}{2} - \sin^{-1} \frac{1}{\sqrt{5}} \right) \right] \\ &= \frac{1}{5} \left[5\sqrt{5} - 5 - 5 \cos^{-1} \frac{1}{\sqrt{5}} \right] \\ &= \alpha\sqrt{5} + \beta + \gamma \cos^{-1} \left(\frac{1}{\sqrt{5}} \right) \\ \therefore \alpha &= \frac{5}{4}, \beta = \frac{-5}{4}, \gamma = \frac{-5}{4} \\ \therefore |\alpha + \beta + \gamma| &= \frac{5}{4} = 1.25 \end{aligned}$$

Question248



The locus of the centroid of the triangle formed by any point P on the hyperbola

$16x^2 - 9y^2 + 32x + 36y - 164 = 0$, and its foci is

[2021,25\$ July Shift-1]

Options:

A. $16x^2 - 9y^2 + 32x - 36y - 36 = 0$

B. $9x^2 - 16y^2 + 36x - 32y - 144 = 0$

C. $16x^2 - 9y^2 + 32x - 36y - 144 = 0$

D. $9x^2 - 16y^2 + 36x - 32y - 36 = 0$

Answer: A

Solution:

Solution:

Given, hyperbola is

$$16x^2 - 9y^2 + 32x - 36y - 164 = 0$$

$$\Rightarrow 16(x+1)^2 - 9(y-2)^2$$

$$= 164 + 16 - 36 = 144$$

$$\Rightarrow \frac{(x+1)^2}{9} - \frac{(y-2)^2}{16} = 1$$

$$\text{Eccentricity, } e = \sqrt{1 + \frac{16}{9}} = \frac{5}{3}$$

\Rightarrow Foci are $(4, 2)$ and $(-6, 2)$.

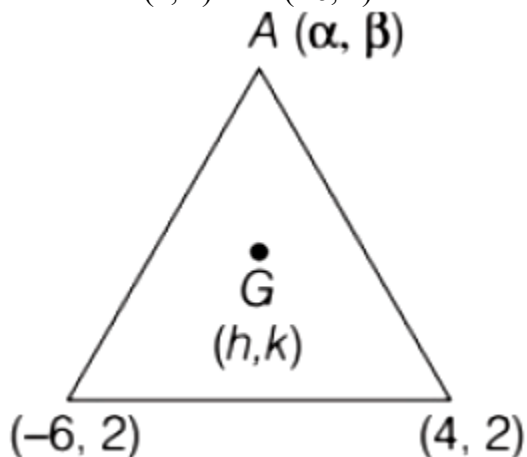

Let the centroid be (h, k) and $A(\alpha, \beta)$ be point on hyperbola

$$\text{So, } h = \frac{\alpha - 6 + 4}{3}, k = \frac{\beta + 2 + 2}{3}$$

$$\Rightarrow \alpha = 3h + 2, \beta = 2k - 4$$

(α, β) lies on hyperbola, so

$$16(3h + 2 + 1)^2 - 9(3k - 4 - 2)^2 = 144$$

$$\Rightarrow 144(h + 1)^2 - 81(k - 2)^2 = 144$$

$$\Rightarrow 16(h^2 + 2h + 1) - 9(k^2 - 4k + 4) = 16$$

$$\Rightarrow 16x^2 - 9y^2 + 32x + 36y - 36 = 0$$

Question249

Let a line $L : 2x + y = k, k > 0$ be a tangent to the hyperbola $x^2 - y^2 = 3$.

If L is also a tangent to the parabola $y^2 = \alpha x$, then α is equal to
[2021, 22 July Shift-II]

Options:

A. 12

B. -12

C. 24

D. -24

Answer: D

Solution:

Solution:

$$T : 2x + y = k$$

$$H : x^2 - y^2 = 3$$

$$P : y^2 = \alpha x$$

If T is tangent, then

$$y = mx \pm \sqrt{a^2 m^2 - b^2}$$

$$y = mx \pm \sqrt{m^2 - 1}$$

$$\Rightarrow y = -2x - k$$

On comparing both sides we get $m = -2$ and $k = 3$

If $2x + y = 3$ is also tangent to $y^2 = \alpha x$,

Then,

$$\begin{aligned} \because m &= -2 \\ \therefore \frac{\alpha}{-8} &= 3 \\ \Rightarrow \alpha &= -24 \end{aligned}$$

Question 250

If the variable line $3x + 4y = \alpha$ lies between the two circles

$$(x - 1)^2 + (y - 1)^2 = 1 \text{ and}$$

$$(x - 9)^2 + (y - 1)^2 = 4, \text{ without}$$

intercepting a chord on either circle, then the sum of all the integral values of α is

[2021, 31 Aug. Shift-1]

Answer: 165

Solution:

Solution:

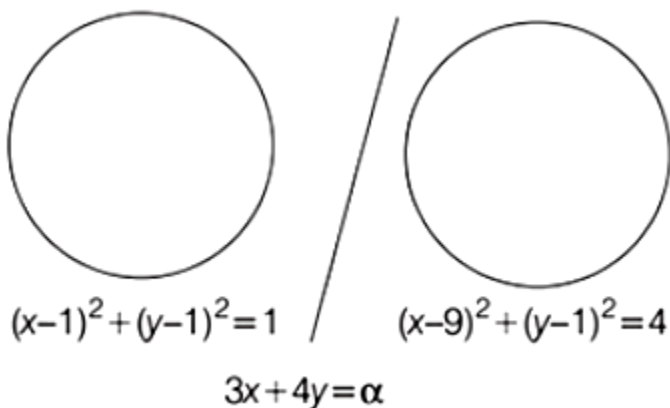

There are 2 possible cases

1. Both centres should lie on different sides of line.
2. Line can be tangent also

Centre of both the circles are $(1, 1)$ and $(9, 1)$

$$(3 + 4 - \alpha)(27 + 4 - \alpha) < 0$$

$$(7 - \alpha)(31 - \alpha) < 0$$

$$\alpha \in (7, 31) \dots\dots\dots (A)$$

$$P_1 = \text{Distance of line from centre } (1, 1)$$

$$P_1 \geq r_1$$

$$\frac{|3 + 4 - \alpha|}{5} \geq 1$$

$$|7 - \alpha| \geq 5$$

$$\alpha \in (-\infty, 2] \cup [12, \infty) \dots\dots\dots (B)$$

Similarly, $P_2 =$ Distance of line from $(9, 1)$

$$\frac{|27 + 4 - \alpha|}{5} \geq 2$$

$$\alpha \in (-\infty, 21] \cup [41, \infty) \dots\dots\dots (C)$$

$$\text{Now, } (A) \cap (B) \cap (C) \Rightarrow \alpha \in [12, 21]$$

$$\text{Sum} = (12 + 13 + 14 + \dots + 21)$$

$$= \left(\frac{21 \times 22}{2} \right) - \left(\frac{11 \times 12}{2} \right)$$

$$= 231 - 66 = 165$$

Question251

Let B be the centre of the circle $x^2 + y^2 - 2x + 4y + 1 = 0$. Let the tangents at two points P and Q on the circle intersect at the point A

$(3, 1)$. Then $8 \left(\frac{\text{area } \Delta APQ}{\text{area } \Delta BPQ} \right)$ is equal to
[2021, 31 Aug. Shift-II]

Answer: 18

Solution:

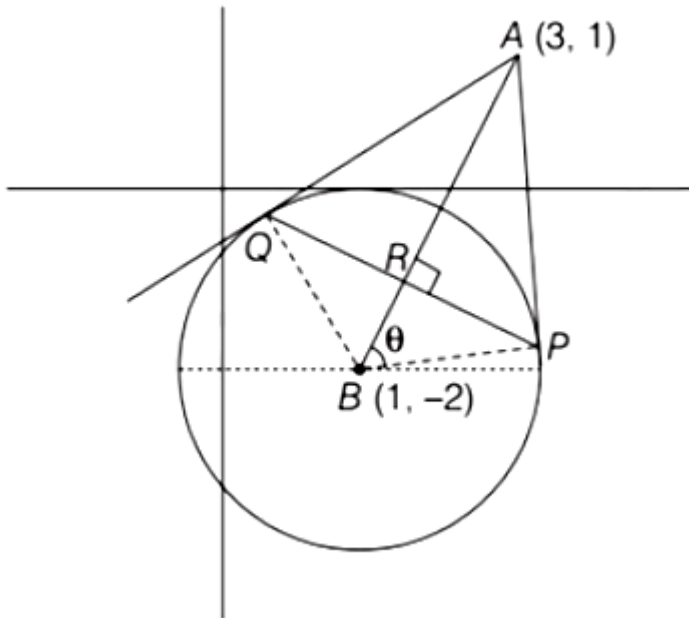

$$\text{Radius} = \sqrt{1+4-1} = 2$$

$$AB = \sqrt{3^2+2^2} = \sqrt{13}$$

In $\triangle ABP$

$$AP^2 = AB^2 - BP^2 = 13 - 4 =$$

$$AP = 3$$

$$AO = AP = 3$$

Let $\angle ABP = \theta$, $\angle BAP = 90 - \theta$

$$\text{In } \triangle ABP, \tan \theta = \frac{3}{2}$$

$$\sin \theta = \frac{3}{\sqrt{13}}, \cos \theta = \frac{2}{\sqrt{13}}$$

In $\triangle ARP$,

$$\cos(90 - \theta) = \frac{AR}{AP} \Rightarrow AR = 3 \sin \theta$$

In $\triangle BRP$

$$\cos \theta = \frac{BR}{BP} \Rightarrow BR = 2 \cos \theta$$

$$= \frac{\text{Area}(\triangle APQ)}{\text{Area}(\triangle BPQ)} = \frac{\frac{1}{2} \times PQ \times AR}{\frac{1}{2} \times PQ \times BR}$$

$$= \frac{AR}{BR} = \frac{3 \sin \theta}{2 \cos \theta} = \frac{9}{4}$$

$$\Rightarrow 8 \left(\frac{\text{Area}(\triangle APQ)}{\text{Area}(\triangle BPQ)} \right) = 18$$

Question252

Let the equation $x^2 + y^2 + px + (1 - p)y + 5 = 0$ represent circles of varying radius $r \in (0, 5]$. Then, the number of elements in the set $S = \{q : q = p^2 \text{ and } q \text{ is an integer}\}$ is
 [2021, 27 Aug. Shift-I]

Answer: 61

Solution:

Solution:

Given equation,

$$x^2 + y^2 + px + (1 - p)y + 5 = 0$$

$$\text{Radius, } r = \sqrt{\left(\frac{p}{2}\right)^2 + \left(\frac{1-p}{2}\right)^2 - 5}$$

$$= \sqrt{\frac{2p^2 - 2p - 19}{4}}$$

Now, $r \in (0, 5]$

$$0 < r \leq 5$$

$$\Rightarrow 0 < \sqrt{\frac{2p^2 - 2p - 19}{4}} \leq 5$$

$$\Rightarrow 0 < \frac{2p^2 - 2p - 19}{4} \leq 25$$

$$\Rightarrow 2p^2 - 2p - 19 > 0 \text{ and}$$

$$2p^2 - 2p - 19 \leq 100$$

$$\Rightarrow 2p^2 - 2p - 19 > 0 \text{ and}$$

$$2p^2 - 2p - 19 \leq 100$$

$$\Rightarrow p^2 - p - \frac{19}{2} > 0 \text{ and } 2p^2 - 2p - 119 \leq 0$$

$$\Rightarrow p \in \left(-\infty, \frac{1 - \sqrt{39}}{2}\right) \cup \left(\frac{1 + \sqrt{39}}{2}, \infty\right)$$

$$\text{and } p \in \left[\frac{1 - \sqrt{239}}{2}, \frac{1 + \sqrt{239}}{2}\right]$$

$$p \in \left[\frac{1 - \sqrt{239}}{2}, \frac{1 - \sqrt{39}}{2}\right] \cup \left[\frac{1 + \sqrt{39}}{2}, \frac{1 + \sqrt{239}}{2}\right]$$

$$\Rightarrow p^2 \in \left[\left(\frac{1 - \sqrt{39}}{2}\right)^2, \left(\frac{1 + \sqrt{239}}{2}\right)^2\right]$$

$$\because q = p^2, q \in \mathbb{Z}$$

$$\Rightarrow q = 7, 8, 9, 10, \dots, 67$$

⇒ 61 integers in S

∴ n(S) = 61

Question253

If the point on the curve $y^2 = 6x$ nearest to the point $\left(3, \frac{3}{2}\right)$ is (α, β) , then $2(\alpha + \beta)$ is equal to
[2021, 20 July Shift-II]

Answer: 9

Solution:

Solution:

Shortest distance is along the normal.

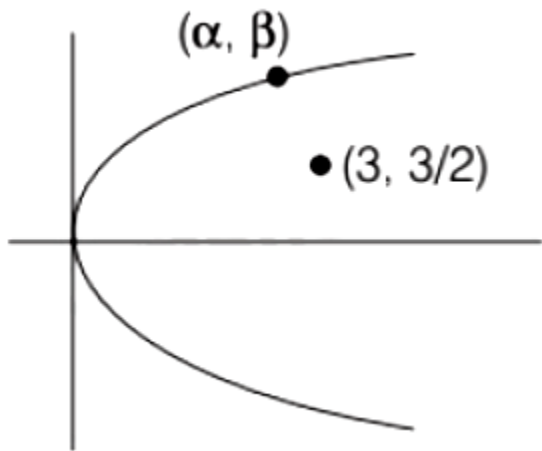

Equation of normal at (α, β)

$$y - \beta = -\frac{\beta}{2\alpha}(x - \alpha)$$

$$(\because y^2 = 4ax \Rightarrow 4a = 6 \Rightarrow 2a = 3)$$

$$\Rightarrow 3y - 3\beta = -\beta(x - \alpha)$$

This normal pass through $\left(3, \frac{3}{2}\right)$.

$$\frac{9}{2} - 3\beta = -3\beta + \alpha\beta \quad \dots\dots\dots (i)$$

$$\text{Now, from } y^2 = 6x \Rightarrow 6\beta^2 = 6\alpha \quad \dots\dots\dots (ii)$$

From Eqs. (i) and (ii),

$$c\alpha = \frac{3}{2}\beta = 3$$

$$\therefore 2(\alpha + \beta) = 2\left(\frac{3}{2} + 3\right) = 2\left(\frac{3+6}{2}\right) = 9$$

Question 254

Two circles each of radius 5 units touch each other at the point (1, 2). If the equation of their common tangent is $4x + 3y = 10$ and $C_1(\alpha, \beta)$ and $C_2(\gamma, \delta)$, $C_1 \neq C_2$ are their centres, then $|(\alpha + \beta)(\gamma + \delta)|$ is equal to [2021, 27 Aug. Shift-II]

Answer: 40

Solution:

Solution:

Equation of circles

$$(x - 1)^2 + (y - 2)^2 + \lambda(4x + 3y - 10) = 0$$

$$x^2 + y^2 + (2\lambda - 1)2x + \left(\frac{3}{2}\lambda - 2\right)$$

$$2y + 5 - 10\lambda = 0$$

$$r = \sqrt{(2\lambda - 1)^2 + \left(\frac{3}{2}\lambda - 2\right)^2 - 5 + 10\lambda} = 5$$

$$\Rightarrow 4\lambda^2 + 1 - 4\lambda + \frac{9}{4}\lambda^2 + 4 - 6\lambda - 5 + 10\lambda = 25$$

$$\Rightarrow \frac{25}{4}\lambda^2 - 25 = 0$$

$$\Rightarrow \lambda = \pm 2$$

For $\lambda = 2$

$$x^2 + y^2 + 6x + 2y - 15 = 0, C_1(-3, -1)$$

For $\lambda = -2$

$$x^2 + y^2 - 10x - 10y + 25 = 0, C_2(5, 5)$$

$$|(\alpha + \beta)(\gamma + \delta)| = |-4 \times 10| = 40$$

Question255

Let Z be the set of all integers, $A = \{(x, y) \in Z \times Z : (x-2)^2 + y^2 \leq 4\}$,
 $B = \{(x, y) \in Z \times Z : x^2 + y^2 \leq 4\}$ and
 $C = \{(x, y) \in Z \times Z : (x-2)^2 + (y-2)^2 \leq 4\}$ If the total number of
relation from $A \cap B$ to $A \cap B$ is 2^p , then the value of p is
[2021,27 Aug. Shift-II]

Options:

- A. 16
- B. 25
- C. 49
- D. 9

Answer: B

Solution:

Solution:

$$A = \{(x, y) \in Z \times Z : (x-2)^2 + y^2 \leq 4\}$$

$$B = \{(x, y) \in Z \times Z : x^2 + y^2 \leq 4\}$$

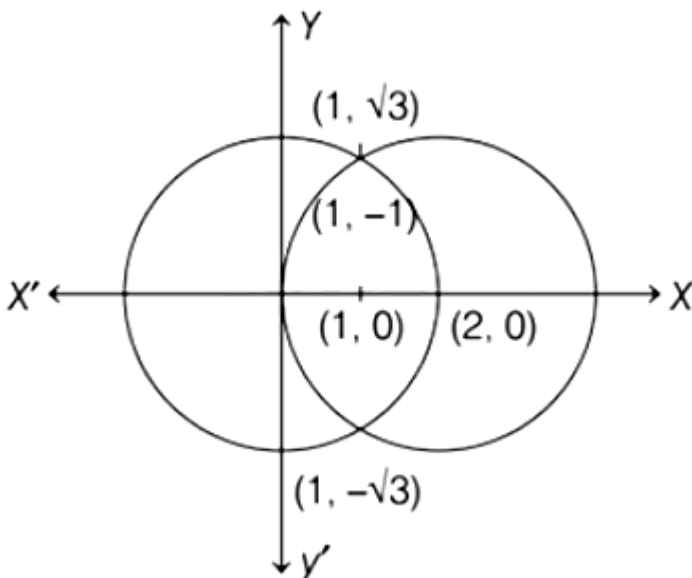

$$C = \{(x, y) \in Z \times Z : (x-2)^2 + (y-2)^2 \leq 4\}$$

$$\therefore A \cap B = \{(0, 0), (1, 0), (2, 0), (1, 1), (1, -1)\}$$

$$n(A \cap B) = 5$$

Similarly, $n(A \cap C) = 5$

Number of relation from $(A \cap B)$ to

$$(A \cap C) = 2^{5 \times 5} = 2^p$$

$$\Rightarrow p = 25$$

Question 256

The locus of a point, which moves such that the sum of squares of its distances from the points $(0, 0)$, $(1, 0)$, $(0, 1)$, $(1, 1)$ is 18 units, is a circle of diameter (d) . Then, d^2 is equal to
[2021, 26 Aug. Shift-1]

Answer: 16

Solution:

Solution:

Let $P(x, y)$ be the required point. Then,

$$(x^2 + y^2) + [x^2 + (y - 1)^2] + [(x - 1)^2 + y^2] + [(x - 1)^2 + (y - 1)^2] = 18$$

$$\Rightarrow 4(x^2 + y^2) - 4y - 4x = 14$$

$$\Rightarrow x^2 + y^2 - x - y - \frac{7}{2} = 0$$

$$\text{Radius} = \sqrt{\left(\frac{1}{2}\right)^2 + \left(\frac{1}{2}\right)^2 + \frac{7}{2}} = 2$$

$$\text{Diameter} = 2 \cdot \text{Radius} = 4$$

$$d^2 = 16$$

Question 257

A circle C touches the line $x = 2y$ at the point $(2, 1)$ and intersects the circle $C_1 : x^2 + y^2 + 2y - 5 = 0$ at two points P and Q such that PQ is a

diameter of C_1 . Then the diameter of C is

[2021, 26 Aug. Shift-11]

Options:

A. $7\sqrt{5}$

B. 15

C. 285

D. $4\sqrt{15}$

Answer: A

Solution:

Solution:

Circle C touches $x = 2y$ at $(2, 1)$, then equation of circle C is given by

$$(x - 2)^2 + (y - 1)^2 + \lambda(x - 2y) = 0$$

$$\Rightarrow x^2 - 4x + 4 + y^2 - 2y + 1 + \lambda x - 2\lambda y = 0$$

$$\Rightarrow x^2 + y^2 + (\lambda - 4)x + (-2 - 2\lambda)y + 5 = 0$$

Since circles C and C_1 intersect each other at PQ, so PQ is common chord

$$\therefore \text{Equation of PQ will be } C - C_1 = 0 \Rightarrow x(\lambda - 4) + y(-4 - 2\lambda) + 10 = 0$$

Again PQ is diameter of circle C_1 .

So, PQ passes through centre of C_1 .

$$\text{Now, equation of } C_1 \text{ is } x^2 + y^2 + 2y - 5 = 0$$

$$\therefore \text{Centre of } C_1 \text{ is } (0, -1).$$

So, PQ passes through $(0, -1)$

$$\therefore 0(\lambda - 4) - 1(-4 - 2\lambda) + 10 = 0 \Rightarrow 4 + 2\lambda + 10 = 0 \Rightarrow \lambda = -7$$

On putting $\lambda = -7$ in Eq. (i), we get equation of circle C as

$$x^2 + y^2 - 11x + 12y + 5 = 0$$

$$\therefore \text{Radius of C} = \sqrt{\left(\frac{11}{2}\right)^2 + (-6)^2 - 5}$$

$$= \sqrt{\frac{121}{4} + 36 - 5}$$

$$= \sqrt{\frac{245}{4}} = \frac{\sqrt{245}}{2}$$

$$\therefore \text{Diameter of C} = 2 \times \text{Radius}$$

$$= \sqrt{245} = 7\sqrt{5}$$

Question258

The length of the latus rectum of a parabola, whose vertex and focus are on the positive X -axis at a distance R and S(>R) respectively from the origin, is

[2021, 31 Aug. Shift-1]

Options:

A. $4(S + R)$

B. $2(S - R)$

C. $4(S - R)$

D. $2(S + R)$

Answer: C

Solution:

Solution:

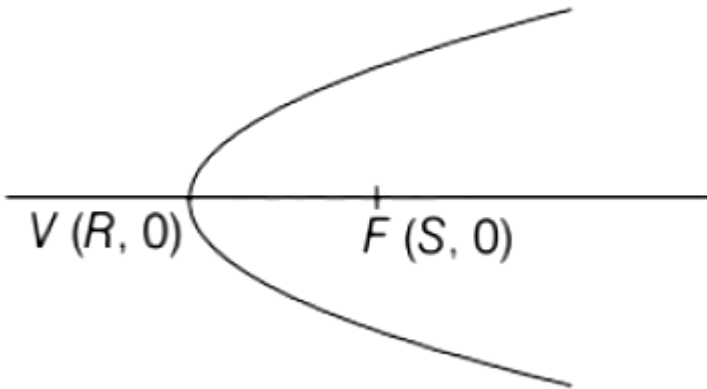

Length of LR of $y^2 = 4ax$ is $4a$.

OR Length of LR = $4 \times$ [Distance between focus and vertex]

Similarly here

Length of LR = $4(S - R)$

Question259

A tangent line L is drawn at the point (2, -4) on the parabola $y^2 = 8x$. If the line L is also tangent to the circle $x^2 + y^2 = a$, then a is equal to [2021, 31 Aug. Shift-II]

Answer: 2

Solution:

Solution:

Equation of tangent to parabola $y^2 = 8x$ at (2, -4) is $-4y = 4(x + 2)$

$$\Rightarrow x + y + 2 = 0$$

Center and radius of circle $x^2 + y^2 = a$ is (0, 0) and \sqrt{a} respectively.

\therefore Eq. (i) is tangent to the circle.

\Rightarrow Perpendicular distance of Eq. (i) from center (0, 0) = \sqrt{a}

$$\Rightarrow \left| \frac{0+0+2}{\sqrt{2}} \right| = \sqrt{a} \Rightarrow a = 2$$

Question260

A tangent and a normal are drawn at the point P(2, -4) on the parabola $y^2 = 8x$, which meet the directrix of the parabola at the points A and B respectively. If Q(a, b) is a point such that AQBP is a square, then $2a + b$ is equal to [2021, 27 Aug. Shift-I]

Options:

A. -16

B. -18

C. -12

D. -20



Answer: A

Solution:

Solution:

Given, parabola

$$y^2 = 8x \quad \dots\dots\dots (i)$$

Equation of tangent at $P(2, -4)$ is

$$-4y = 4(x + 2)$$

$$\text{or } x + y + 2 = 0 \quad \dots\dots\dots (ii)$$

and Equation of normal to the parabola is

$$x - y + C = 0$$

\therefore Normal passes through $(2, -4)$

$$\therefore C = -6 \quad \dots\dots\dots (iii)$$

$$\text{Normal: } x - y = 6$$

Equation of directrix of parabola

$$x = -2 \quad \dots\dots\dots (iv)$$

Point of intersection of tangent and normal with directrix are $x = -2$ at $A(-2, 0)$ and $B(-2, -8)$ respectively. $O(a, b)$ and $P(2, -4)$ are given and $AQBP$ is a square.

Mid-point of $AB =$ Mid-point of PQ

$$\Rightarrow (-2, -4) = \left(\frac{a+2}{2}, \frac{b-4}{2} \right)$$

$$\Rightarrow a = -6, b = -4$$

$$\Rightarrow 2a + b = -16$$

Question261

If two tangents drawn from a point P to the parabola $y^2 = 16(x - 3)$ are at right angles, then the locus of point P is

[2021, 27 Aug. Shift-II]

Options:

A. $x + 3 = 0$

B. $x + 1 = 0$

C. $x + 2 = 0$

D. $x + 4 = 0$

(d) $x + 4 = 0$

Answer: B

Solution:

Solution:

We know that, the locus of the points of intersection of the mutually perpendicular tangents to a parabola is the directrix of the parabola(a)

$$\Rightarrow X + A = 0$$

$$\Rightarrow x - 3 + 4 = 0$$

$$\Rightarrow x + 1 = 0$$

Question262

If a line along a chord of the circle $4x^2 + 4y^2 + 120x + 675 = 0$, passes through the point $(-30, 0)$ and is tangent to the parabola $y^2 = 30x$, then the length of this chord is
[2021, 26 Aug Shift-I]

Options:

A. 5

B. 7

C. $5\sqrt{3}$

D. $3\sqrt{5}$

Answer: D

Solution:

Solution:

Equation of tangent to $y^2 = 30x$ is

$$y = mx + \frac{30}{4m}$$

Now, this tangent passes through $(-30, 0)$.

$$\therefore 0 = -30m + \frac{30}{4m}$$

$$\Rightarrow \frac{30}{4m} = 30m \Rightarrow m^2 = \frac{1}{4}$$



$$\Rightarrow m = \pm \frac{1}{2}$$

\therefore Equation of tangent is

$$y = \frac{x}{2} + 15$$

or

$$y = -\frac{x}{2} - 15$$

Now equation of circle is

$$x^2 + y^2 + 30x + \frac{675}{4} = 0$$

Let perpendicular distance of the tangent from the centre $(-15, 0)$ of the circle = p

$$\therefore p = \frac{\left| \frac{-15}{2} + 15 \right|}{\sqrt{1 + \frac{1}{4}}} = 3\sqrt{5}$$

$$\begin{aligned} \therefore \text{Length of chord} &= 2\sqrt{r^2 - p^2} \\ &= 2\sqrt{\left(15^2 + 0 - \frac{675}{4}\right) - 45} \\ &= 3\sqrt{5} \end{aligned}$$

where, r is radius of the given circle.

Question263

The line $12x \cos \theta + 5y \sin \theta = 60$ is tangent to which of the following curves?

[2021, 31 Aug. Shift-1]

Options:

A. $x^2 + y^2 = 169$

B. $144x^2 + 25y^2 = 3600$

C. $25x^2 + 12y^2 = 3600$

D. $x^2 + y^2 = 60$

Answer: B

Solution:

$$12x \cos \theta + 5y \sin \theta = 60$$

$$\Rightarrow \frac{x \cos \theta}{5} + \frac{y \sin \theta}{12} = 1$$

The given equation is the equation of the tangent which passes through $(5 \cos \theta, 12 \sin \theta)$.

Hence, the given equation is tangent to

$$\frac{x^2}{25} + \frac{y^2}{144} = 1 \text{ at } (5 \cos \theta, 12 \sin \theta).$$

Question 264

The locus of mid-points of the line segments joining $(-3, -5)$ and the points on the ellipse $\frac{x^2}{4} + \frac{y^2}{9} = 1$ is
[2021, 31 Aug. Shift-II]

Options:

- A. $9x^2 + 4y^2 + 18x + 8y + 145 = 0$
- B. $36x^2 + 16y^2 + 90x + 56y + 145 = 0$
- C. $36x^2 + 16y^2 + 108x + 80y + 145 = 0$
- D. $36x^2 + 16y^2 + 72x + 32y + 145 = 0$

Answer: C

Solution:

Solution:

Let $(2 \sin \theta, 3 \cos \theta)$ be the point on ellipse $\frac{x^2}{4} + \frac{y^2}{9} = 1$ and let mid-point of the line segments joining $(-3, -5)$ and $(2 \sin \theta, 3 \cos \theta)$ will be (h, k) .

$$\text{Then, } \frac{2 \sin \theta - 3}{2} = h, \frac{3 \cos \theta - 5}{2} = k$$

$$\Rightarrow \sin \theta = \frac{2h + 3}{2}, \cos \theta = \frac{2k + 5}{3}$$

$$\therefore \sin^2 \theta + \cos^2 \theta = 1$$

$$\Rightarrow \left(\frac{2h + 3}{2} \right)^2 + \left(\frac{2k + 5}{3} \right)^2 = 1$$

$$\Rightarrow \frac{(4h^2 + 9 + 12h)}{4} + \frac{(4k^2 + 25 + 20k)}{9} = 1$$

$$\Rightarrow 36h^2 + 16k^2 + 108h + 80k + 145 = 0$$

Locus of (h, k)

$$36x^2 + 16y^2 + 108x + 80y + 145 = 0$$

Question 265

If the minimum area of the triangle formed by a tangent to the ellipse

$$\frac{x^2}{b^2} + \frac{y^2}{4a^2} = 1 \text{ and the coordinate axis is } kab, \text{ then } k \text{ is equal to}$$

[2021, 27 Aug. Shift-I]

Answer: 2

Solution:

Solution:

Equation of an ellipse $B(0, 2a \operatorname{cosec} \theta)$

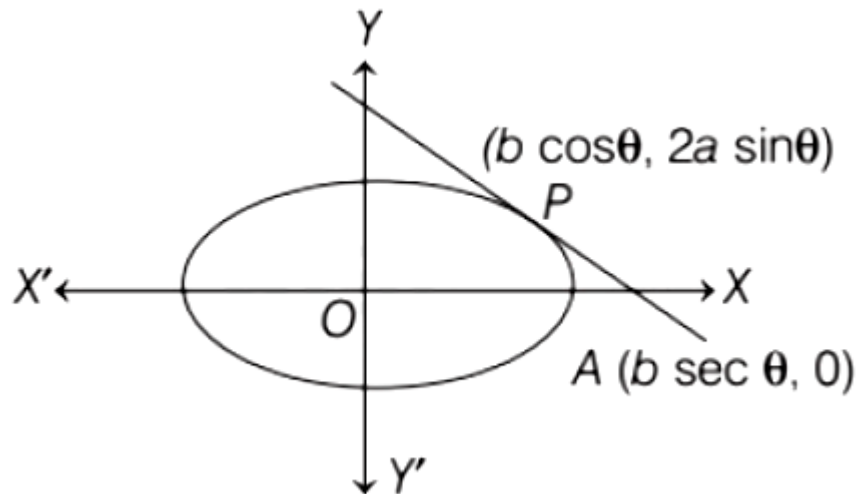

$$\frac{x^2}{b^2} + \frac{y^2}{4a^2} = 1$$

Equation of tangent at $P(b \cos \theta, 2a \sin \theta)$ is

$$\frac{x \cos \theta}{b} + \frac{y \sin \theta}{2a} = 1$$

Point of intersection of tangent and coordinate axis are

$A(b \sec \theta, 0)$ and $B(0, 2a \operatorname{cosec} \theta)$

$$\text{Area of } \triangle OAB = \frac{1}{2}(b \sec \theta)(2a \operatorname{cosec} \theta)$$

$$= \frac{ab}{\sin \theta \cos \theta} = \frac{2ab}{\sin 2\theta}$$

$$\text{or Area} = 2ab(\operatorname{cosec} 2\theta)$$

$$\text{Area}_{\min} = 2ab$$

$$\therefore k = 2$$

Question 266

If $x^2 + 9y^2 - 4x + 3 = 0$, $x, y \in \mathbf{R}$, then x and y respectively lie in the intervals

[2021, 27 Aug. Shift-I]

Options:

A. $\left[-\frac{1}{3}, \frac{1}{3}\right]$ and $\left[-\frac{1}{3}, \frac{1}{3}\right]$

B. $\left[-\frac{1}{3}, \frac{1}{3}\right]$ and $[1, 3]$

C. $[1, 3]$ and $[1, 3]$

D. $[1, 3]$ and $\left[-\frac{1}{3}, \frac{1}{3}\right]$

Answer: D

Solution:

Solution:

$$\begin{aligned} x^2 + 9y^2 - 4x + 3 &= 0 \\ \Rightarrow x^2 - 4x + 2^2 + 9y^2 &= 1 \\ \Rightarrow (x-2)^2 + 9y^2 &= 1 \\ \Rightarrow \frac{(x-2)^2}{1} + \frac{y^2}{1/9} &= 1 \\ \Rightarrow \frac{(x-2)^2}{1^2} + \frac{y^2}{\left(\frac{1}{3}\right)^2} &= 1 \end{aligned}$$

This represents an ellipse

$$-1 \leq x-2 \leq 1 \text{ and } -\frac{1}{3} \leq y \leq \frac{1}{3}$$

$$\Rightarrow 1 \leq x \leq 3 \text{ and } -\frac{1}{3} \leq y \leq \frac{1}{3}$$

$$\Rightarrow x \in [1, 3] \text{ and } y \in \left[-\frac{1}{3}, \frac{1}{3}\right]$$

Question 267

On the ellipse $\frac{x^2}{8} + \frac{y^2}{4} = 1$. Let P be a point in the second quadrant such that the tangent at P to the ellipse is perpendicular to the line $x + 2y = 0$. Let S and S' be the foci of the ellipse and e be its eccentricity. If A is the area of the $\triangle SPS'$ then, the value of $(5 - e^2) \cdot A$ is

[2021, 26 Aug. Shift-1]

Options:

A. 6

B. 12

C. 14

D. 24

Answer: A

Solution:

Solution:

Given, equation of ellipse $\frac{x^2}{8} + \frac{y^2}{4} = 1$

Then, equation of tangent at (x_1, y_1) will be $\frac{xx_1}{8} + \frac{yy_1}{4} = 1$

Since, tangent is perpendicular to the line $x + 2y = 0$, then

$$\left(\frac{-x_1}{2y_1}\right) \left(\frac{-1}{2}\right) = -1$$

$$\Rightarrow x_1 = -4y_1$$

Also, $\frac{x_1^2}{8} + \frac{y_1^2}{4} = 1$

$\Rightarrow \frac{16y_1^2}{8} + \frac{y_1^2}{4} = 1$ [$\because x_1 = -4y_1$]

$\Rightarrow \frac{9}{4}y_1^2 = 1 \Rightarrow y_1^2 = \frac{4}{9}$

$\Rightarrow y_1 = \pm \frac{2}{3} \Rightarrow y_1 = \frac{2}{3}$

[$\because (x_1, y_1)$ lies in second quadrant]

And $x_1 = -4y_1 = -4 \times \frac{2}{3} = \frac{-8}{3}$

$\therefore P\left(\frac{-8}{3}, \frac{2}{3}\right)$

Again, $a^2 - b^2 = a^2 e^2$

$8 - 4 = 8e^2$

$e = \frac{1}{\sqrt{2}}$

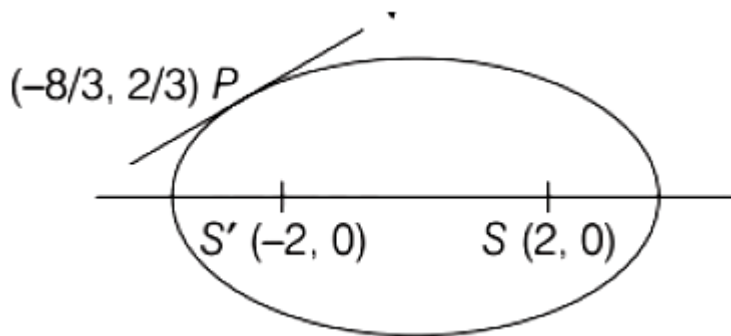

Now, S and S' are the foci of the ellipse,

So, S : (ae, 0)

$= \left(2\sqrt{2} \cdot \frac{1}{\sqrt{2}}, 0\right) = (2, 0)$

and S' : (-ae, 0) = $\left(-2\sqrt{2} \cdot \frac{1}{\sqrt{2}}, 0\right) = (-2, 0)$

Area of $\triangle SPS'$ = $\frac{1}{2} \times 4 \times \frac{2}{3} = \frac{4}{3}$

[\because base = 4, height = $\frac{2}{3}$]

So, $(5 - e^2)A = \left(5 - \frac{1}{2}\right) \frac{4}{3} = \frac{9}{2} \cdot \frac{4}{3} = 6$

Question 268

Let A(sec θ , 2 tan θ) and B(sec ϕ , 2 tan ϕ), where $\theta + \phi = \pi/2$, be two points on the hyperbola $2x^2 - y^2 = 2$. If (α , β) is the point of the intersection of the normals to the hyperbola at A and B, then $(2\beta)^2$ is

equal to
[2021, 27 Aug. Shift-II]

Answer: 1.56

Solution:

Solution:

Let $A(\sec \theta, 2 \tan \theta)$ lie on hyperbola

$$2x^2 - y^2 = 2$$

$$\Rightarrow 2(1 + \tan^2 \theta) - 4 \tan^2 \theta = 2$$

$$\Rightarrow 2 \tan^2 \theta = 0$$

$$\Rightarrow \tan \theta = 0$$

$$\Rightarrow \theta = 0$$

Similarly, point $B(\sec \phi, 2 \tan \phi)$ lie on hyperbola

$$\Rightarrow \tan \phi = 0$$

$$\Rightarrow \phi = 0$$

$$\Rightarrow \theta + \phi = 0$$

But in question it is given that, $\theta + \phi = \frac{\pi}{2}$ which is not possible.

Question 269

The point $P(-2\sqrt{6}, \sqrt{3})$ lies on the hyperbola $\frac{x^2}{a^2} - \frac{y^2}{b^2} = 1$ having eccentricity $\frac{\sqrt{5}}{2}$. If the tangent and normal at P to the hyperbola intersect its conjugate axis at the point Q and R respectively, then QR is equal to

[2021, 26 Aug. Shift-II]

Options:

A. $4\sqrt{3}$

B. 6

C. $6\sqrt{3}$

D. $3\sqrt{6}$

Answer: C

Solution:

Solution:

$$a^2 + b^2 = a^2 e^2$$

$$a^2 + b^2 = a^2 \left(\frac{5}{4} \right)$$

$$\frac{x^2}{a^2} - \frac{y^2}{b^2} = 1$$

∴ Point P($-2\sqrt{6}$, $\sqrt{3}$) lies on given ellips.

$$\therefore \frac{24}{4b^2} - \frac{3}{b^2} = 1$$

$$\Rightarrow b^2 = 3 \Rightarrow a^2 = 12$$

Equation of tangent at P

$$\frac{x(-2\sqrt{6})}{12} - \frac{y(\sqrt{3})}{3} = 1$$

For conjugate axis, put $x = 0$

$$\therefore Q(0, $-\sqrt{3}$)$$

Equation of normal at P

$$\frac{y - \sqrt{3}}{x + 2\sqrt{6}} = \left(\frac{-1}{\sqrt{3}} \right) \times \left(\frac{12}{-2\sqrt{6}} \right)$$

$$\Rightarrow y - \sqrt{3} = 2\sqrt{12} = 4\sqrt{3}$$

$$\Rightarrow y = 5\sqrt{3}$$

$$\therefore R(0, $5\sqrt{3}$)$$

$$\Rightarrow QR = $6\sqrt{3}$$$

Question270

The locus of the mid-points of the chords of the hyperbola $x^2 - y^2 = 4$, which touch the parabola $y^2 = 8x$, is
[2021, 26 Aug. Shift-II]

Options:

A. $y^3(x - 2) = x^2$

B. $x^3(x - 2) = y^2$

$$C. y^2(x - 2) = x^3$$

$$D. x^2(x - 2) = y^3$$

Answer: C

Solution:

Solution:

Let the mid-point of the chord is (h, k) . Then, chord through mid-point (h, k) is

$$T = S_1$$

$$xh - yk = h^2 - k^2 \quad \dots\dots\dots (i)$$

Now, this is also a tangent of $y^2 = 8x$. The equation of the tangent of slope m to the parabola $y^2 = 8x$ is given by

$$\text{Tangent : } y = mx + \frac{2}{m}$$

$$\Rightarrow m^2x - my = -2 \quad \dots\dots\dots (ii)$$

Eqs. (i) and (ii) are coincide

$$\therefore \frac{h}{m^2} = \frac{-k}{-m} = \frac{h^2 - k^2}{-2}$$

$$\Rightarrow h = km \Rightarrow m = \frac{h}{k}$$

$$\therefore \frac{k^2}{h} = \frac{h^2 - k^2}{-2}$$

$$\Rightarrow -2k^2 = h^3 - hk^2$$

$$h^3 = k^2(h - 2)$$

Therefore, locus of mid-point of the chords, $x^3 = y^2(x - 2)$

Question271

Consider the parabola with vertex $\left(\frac{1}{2}, \frac{3}{4}\right)$ and the directrix $y = \frac{1}{2}$. Let

P be the point where the parabola meets the line $x = -\frac{1}{2}$. If the normal to the parabola at P intersects the parabola again at the point Q, then

$(PQ)^2$ is equal to

[2021, 01 Sep. Shift-11]

Options:

A. $\frac{75}{8}$

B. $\frac{125}{16}$

C. $\frac{25}{2}$

D. $\frac{15}{2}$

Answer: B

Solution:

Solution:

Vertex $\left(\frac{1}{2}, \frac{3}{4}\right)$

Equation of directrix $y = \frac{1}{2}$

Equation of parabola is $\left(x - \frac{1}{2}\right)^2 = y - \frac{3}{4}$

Point on parabola P $\left(\frac{-1}{2}, \frac{7}{4}\right)$

Equation of normal at P $\left(\frac{-1}{2}, \frac{7}{4}\right)$ is $x = 2y - 4$

This normal cuts the parabola at Q(2, 3)

$$(PQ)^2 = \left(2 + \frac{1}{2}\right)^2 + \left(3 - \frac{7}{4}\right)^2 = \frac{125}{16}$$

Question272

Let θ be the acute angle between the tangents to the ellipse $\frac{x^2}{9} + \frac{y^2}{1} = 1$ and the circle $x^2 + y^2 = 3$ at their point of intersection in the first quadrant. Then, $\tan \theta$ is equal to
[2021, 01 Sep. Shift-II]

Options:

A. $\frac{5}{2\sqrt{3}}$

B. $\frac{2}{\sqrt{3}}$

C. $\frac{4}{\sqrt{3}}$

D. 2

Answer: B

Solution:

Solution:

Given, ellipse $\frac{x^2}{9} + \frac{y^2}{1} = 1$ (i)

and circle $x^2 + y^2 = 3$ (ii)

The point of intersection by solving Eqs.

(i) and (ii) in

first quadrant $(3/2, \sqrt{3}/2)$.

Differentiating Eqs. (i) and (ii) w.r.t. x, we have

Let $m_1 = \frac{dy}{dx} = \frac{-x}{9y}$ and $m_2 = \frac{dy}{dx} = \frac{-x}{y}$

At $\left(\frac{3}{2}, \frac{\sqrt{3}}{2}\right)$

$m_1 = -\frac{1}{3\sqrt{3}}, m_2 = -\sqrt{3}$

If angle between both curves is θ , then

$$\tan \theta = \left| \frac{m_1 - m_2}{1 + m_1 m_2} \right|$$

$$= \left| \frac{\frac{-1}{3\sqrt{3}} + \sqrt{3}}{1 + \left(\frac{-1}{3\sqrt{3}}\right)(-\sqrt{3})} \right| = \frac{2}{\sqrt{3}}$$

Question273

If a hyperbola passes through the point P(10, 16) and it has vertices at $(\pm 6, 0)$, then the equation of the normal to it at P is:

[Jan. 8, 2020 (II)]

Options:

A. $3x + 4y = 94$

B. $2x + 5y = 100$

C. $x + 2y = 42$

D. $x + 3y = 58$

Answer: B

Solution:

Solution:

Let the hyperbola is $\frac{x^2}{a^2} - \frac{y^2}{b^2} = 1$

If a hyperbola passes through vertices at $(\pm 6, 0)$, then

$\therefore a = 6$

As hyperbola passes through the point $P(10, 16)$

$$\frac{100}{36} - \frac{256}{b^2} = 1 \Rightarrow b^2 = 144$$

\therefore Required hyperbola is $\frac{x^2}{36} - \frac{y^2}{144} = 1$

Equation of normal is $\frac{36x}{10} + \frac{144y}{16} = 36 + 144$

At $P(10, 16)$ normal is

$$\frac{36x}{10} + \frac{144y}{16} = 36 + 144$$

$\therefore 2x + 5y = 100$

Question274

**A circle touches the y -axis at the point (0,4) and passes through the point (2,0) . Which of the following lines is not a tangent to this circle?
[Jan. 9, 2020 (I)]**

Options:

A. $4x - 3y + 17 = 0$

B. $3x - 4y - 24 = 0$

C. $3x + 4y - 6 = 0$

D. $4x + 3y - 8 = 0$

Answer: D

Solution:

Solution:

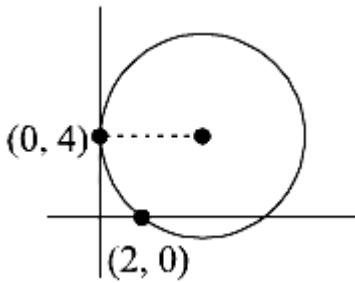

Equation of family of circle

$$(x - 0)^2 + (y - 4)^2 + \lambda x = 0$$

Passes through the point (2,0) then

$$4 + 16 + 2\lambda = 0 \Rightarrow \lambda = -10$$

Hence, the equation of circle

$$x^2 + y^2 - 10x - 8y + 16 = 0$$

$$\Rightarrow (x - 5)^2 + (y - 4)^2 = 25$$

Centre (5,4)

$$R = \sqrt{\frac{1}{2} \text{coeff. of } x + \frac{1}{2} \text{coeff. of } y - \text{constant}}$$

$$= \sqrt{25 + 16 - 16} = 5$$

Perpendicular distance of $4x + 3y - 8 = 0$ from the centre of circle

$$= \left| \frac{20 + 16 - 8}{\sqrt{16 + 9}} \right| = \frac{28}{5} \neq 5$$

Hence, $4x + 3y - 8 = 0$ can not be tangent to the circle.

Question275

If the curves, $x^2 - 6x + y^2 + 8 = 0$ and $x^2 - 8y + y^2 + 16 - k = 0$, ($k > 0$) touch each other at a point, then the largest value of k is _____.

[NA Jan. 9, 2020 (II)]

Answer: 36

Solution:

Solution:

The given equation of circle

$$x^2 - 6x + y^2 + 8 = 0$$

$$(x - 3)^2 + y^2 = 1 \dots (i)$$

So, centre of circle (i) is $C_1(3, 0)$ and radius $r_1 = 1$

And the second equation of circle

$$x^2 - 8y + y^2 + 16 - k = 0 (k > 0)$$

$$x^2 + (y - 4)^2 = (\sqrt{k})^2$$

So, centre of circle (ii) is $C_2(0, 4)$ and radius $r_2 = \sqrt{k}$

Two circles touches each other when

$$C_1C_2 = |r_1 \pm r_2| \Rightarrow 5 = |1 \pm \sqrt{k}|$$

Distance between $C_2(3, 0)$ and $C_1(0, 4)$ is either $\sqrt{k} + 1$ or $|\sqrt{k} - 1|$ ($C_1C_2 = 5$)

$$\Rightarrow \sqrt{k} + 1 = 5 \quad \text{or} \quad |\sqrt{k} - 1| = 5$$

$$\Rightarrow k = 16 \quad \text{or} \quad k = 36$$

Hence, maximum value of k is 36

The given equation of circles $x^2 - 6x + y^2 + 8 = 0$

$$\Rightarrow (x - 3)^2 + y^2 = 1$$

Question 276

If a line, $y = mx + c$ is a tangent to the circle, $(x - 3)^2 + y^2 = 1$ and it is perpendicular to a line L_1 , where L_1 is the tangent to the circle,

$x^2 + y^2 = 1$ at the point $\left(\frac{1}{\sqrt{2}}, \frac{1}{\sqrt{2}} \right)$; then:

[Jan. 8, 2020 (II)]

Options:

A. $c^2 - 7c + 6 = 0$

B. $c^2 + 7c + 6 = 0$

C. $c^2 + 6c + 7 = 0$

D. $c^2 - 6c + 7 = 0$

Answer: C

Solution:

Solution:

Slope of tangent of $x^2 + y^2 = 1$ at $\left(\frac{1}{\sqrt{2}}, \frac{1}{\sqrt{2}}\right)$

$$\frac{1}{\sqrt{2}}x + \frac{1}{\sqrt{2}}y - 1 = 0$$

$x + y\sqrt{2} = 0$, which is perpendicular to $x - y + c = 0$

At $\left(\frac{1}{\sqrt{2}}, \frac{1}{\sqrt{2}}\right)$ which is tangent of $(x - 3)^2 + y^2 = 1$

So, $m = 1 \Rightarrow y = x + c$

Now, distance of $(3, 0)$ from $y = x + c$ is $\left| \frac{c+3}{\sqrt{2}} \right| = 1$

$$\Rightarrow c = -3 \pm \sqrt{2}$$

$$\Rightarrow (c+3)^2 = 2$$

$$\Rightarrow c^2 + 6c + 9 = 2$$

$$\therefore c^2 + 6c + 7 = 0$$

Question 277

Let the tangents drawn from the origin to the circle,

$x^2 + y^2 - 8x - 4y + 16 = 0$ touch it at the points A and B. The $(AB)^2$ is equal to:

[Jan. 7, 2020 (II)]

Options:

A. $\frac{52}{5}$

B. $\frac{56}{5}$

C. $\frac{64}{5}$

D. $\frac{32}{5}$

Answer: C

Solution:

Solution:

$$L = \sqrt{S_1} = \sqrt{16} = 4$$

$$R = \sqrt{16 + 4 - 16} = 2$$

Length of chord of contact

$$= \frac{2LR}{\sqrt{L^2 + R^2}} = \frac{2 \times 4 \times 2}{\sqrt{16 + 4}} = \frac{16}{\sqrt{20}}$$

$$\text{Square of length of chord of contact} = \frac{64}{5}$$

Question278

If one end of a focal chord AB of the parabola $y^2 = 8x$ is at $A\left(\frac{1}{2}, -2\right)$,

then the equation of the tangent to it at B is:

[Jan. 9, 2020 (II)]

Options:

A. $2x + y - 24 = 0$

B. $x - 2y + 8 = 0$

C. $x + 2y + 8 = 0$

D. $2x - y - 24 = 0$

Answer: B

Solution:

Solution:

Let parabola $y^2 = 8x$ at point $\left(\frac{1}{2}, -2\right)$ is $(2t^2, 4t)$

$$\Rightarrow t = \frac{-1}{2}$$

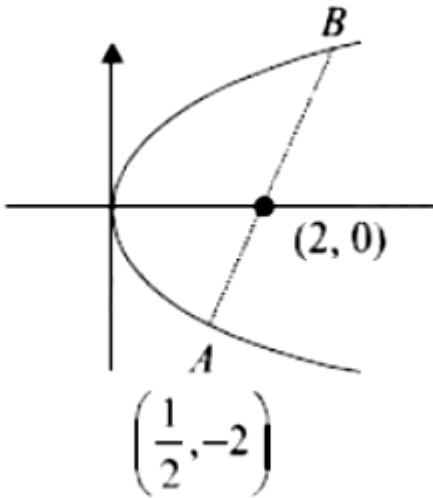

Parameter of other end of focal chord is 2 So, coordinates of B is (8,8)
 \Rightarrow Equation of tangent at B is $8y - 4(x + 8) = 0$
 $\Rightarrow 2y - x = 8$
 $\Rightarrow x - 2y + 8 = 0$

Question279

The locus of a point which divides the line segment joining the point (0,-1) and a point on the parabola, $x^2 = 4y$, internally in the ratio 1 : 2, is:

[Jan. 8, 2020 (I)]

Options:

A. $9x^2 - 12y = 8$

B. $9x^2 - 3y = 2$

C. $x^2 - 3y = 2$

D. $4x^2 - 3y = 2$

Answer: A

Solution:

Solution:

Let point P be $(2t, t^2)$ and Q be (h, k) Using section formula,

$$h = \frac{2t}{3}, k = \frac{-2+t^2}{3}$$

$$\text{Hence, locus is } 3k+2 = \left(\frac{3h}{2}\right)^2$$

$$\Rightarrow 9x^2 = 12y + 8$$

Question280

Let a line $y = mx (m > 0)$ intersect the parabola, $y^2 = x$ at a point P, other than the origin. Let the tangent to it at P meet the x-axis at the point Q, If area $(\Delta OPQ) = 4$ sq. units, then m is equal to _____.
[NA Jan. 8, 2020 (II)]

Answer: 0.5

Solution:

Solution:

Let the coordinates of P = $P(t^2, t)$

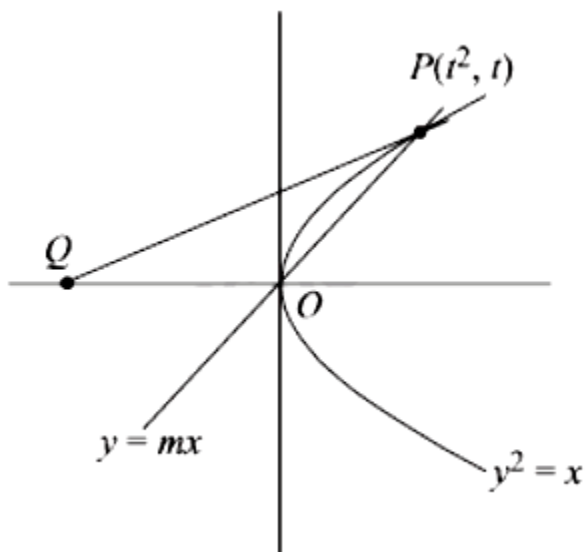

$$\text{Tangent at } P(t^2, t) \text{ is } ty = \frac{x+t^2}{2}$$

$$\Rightarrow 2ty = x + t^2$$

$$Q(-t^2, 0), O(0, 0)$$

$$\text{Area of } \triangle OPQ = \frac{1}{2} \begin{vmatrix} 0 & 0 & 1 \\ t^2 & t & 1 \\ -t^2 & 0 & 1 \end{vmatrix} = 4$$

$$\Rightarrow |t|^3 = 8$$

$$t = \pm 2 (t > 0)$$

$\therefore 4y = x + 4$ is a tangent $\therefore P$ is (4,2)

$$\text{Now, } y = mx \quad \therefore m = \frac{1}{2}$$

Question 281

If e_1 and e_2 are the eccentricities of the ellipse, $\frac{x^2}{18} + \frac{y^2}{4} = 1$ and the hyperbola, $\frac{x^2}{9} - \frac{y^2}{4} = 1$ respectively and (e_1, e_2) is a point on the ellipse, $15x^2 + 3y^2 = k$, then k is equal to
[Jan. 9, 2020 (I)]

Options:

A. 16

B. 17

C. 15

D. 14

Answer: A

Solution:

Solution:

Eccentricity of ellipse

$$e_1 = \sqrt{1 - \frac{4}{18}} = \sqrt{\frac{7}{9}} = \frac{\sqrt{7}}{3}$$

Eccentricity of hyperbola

$$e_2 = \sqrt{1 + \frac{4}{9}} = \sqrt{\frac{13}{9}} = \frac{\sqrt{13}}{3}$$

Since, the point (e_1, e_2) is on the ellipse

$$15x^2 + 3y^2 = k$$



$$\text{Then, } 15e_1^2 + 3e_2^2 = k$$

$$\Rightarrow k = 15\left(\frac{7}{9}\right) + 3\left(\frac{13}{9}\right)$$

$$\Rightarrow k = 16$$

Question 282

The length of the minor axis (along y-axis) of an ellipse in the standard form is $\frac{4}{\sqrt{3}}$. If this ellipse touches the line, $x + 6y = 8$; then its

eccentricity is:

[Jan. 9, 2020 (II)]

Options:

A. $\frac{1}{2} \sqrt{\frac{11}{3}}$

B. $\sqrt{\frac{5}{6}}$

C. $\frac{1}{2} \sqrt{\frac{5}{3}}$

D. $\frac{1}{3} \sqrt{\frac{11}{3}}$

Answer: A

Solution:

Solution:

$$\text{Let } \frac{x^2}{a^2} + \frac{y^2}{b^2} = 1; a > b$$

$$2b = \frac{4}{\sqrt{3}} \Rightarrow b = \frac{2}{\sqrt{3}}$$

$$\text{Equation of tangent } \Rightarrow y = mx \pm \sqrt{a^2m^2 + b^2}$$

$$\text{Comparing with } \Rightarrow y = \frac{-x}{6} + \frac{4}{3}$$

$$m = \frac{-1}{6} \text{ and } a^2m^2 + b^2 = \frac{16}{9}$$

$$\Rightarrow \frac{a^2}{36} + \frac{4}{3} = \frac{16}{9} \Rightarrow \frac{a^2}{36} = \frac{16}{9} - \frac{4}{3} = \frac{4}{9}$$

$$\Rightarrow a^2 = 16 \Rightarrow a = \pm 4$$

$$\text{Now, eccentricity of ellipse (e)} = \sqrt{1 - \frac{b^2}{a^2}}$$

$$\Rightarrow e = \sqrt{1 - \frac{4}{3 \times 16}} = \sqrt{\frac{11}{12}} = \frac{1}{2} \sqrt{\frac{11}{3}}$$

Question 283

Let the line $y = mx$ and the ellipse $2x^2 + y^2 = 1$ intersect at a point P in the first quadrant. If the normal to this ellipse at P meets the co-

ordinate axes at $\left(-\frac{1}{3\sqrt{2}}, 0\right)$ and $(0, \beta)$, then β is equal to:

[Jan. 8, 2020 (I)]

Options:

A. $\frac{2\sqrt{2}}{3}$

B. $\frac{2}{\sqrt{3}}$

C. $\frac{2}{3}$

D. $\frac{\sqrt{2}}{3}$

Answer: D

Solution:

Solution:

Let P be (x_1, y_1) .

So, equation of normal at P is

$$\frac{x}{2x_1} - \frac{y}{y_1} = -\frac{1}{2}$$

It passes through $\left(-\frac{1}{3\sqrt{2}}, 0\right)$

$$\Rightarrow \frac{-1}{6\sqrt{2}x_1} = -\frac{1}{2} \Rightarrow x_1 = \frac{1}{3\sqrt{2}}$$

$$\text{So, } y_1 = \frac{2\sqrt{2}}{3} \left(\text{as P lies in I}^{\text{th}} \text{ quadrant} \right)$$

$$\text{So, } \beta = \frac{y_1}{2} = \frac{\sqrt{2}}{3}$$

Question284

If the distance between the foci of an ellipse is 6 and the distance between its directrices is 12, then the length of its latus rectum is:
[Jan. 7, 2020 (I)]

Options:

A. $\sqrt{3}$

B. $3\sqrt{2}$

C. $\frac{3}{\sqrt{2}}$

D. $2\sqrt{3}$

Answer: B

Solution:

Solution:

$$2ae = 6 \text{ and } \frac{2a}{e} = 12$$

$$\Rightarrow ae = 3 \dots\dots (i)$$

$$\text{and } \frac{a}{e} = 6 \Rightarrow e = \frac{a}{6} \dots (ii)$$

$$\Rightarrow a^2 = 18 \text{ [From (i) and (ii)]}$$

$$\Rightarrow b^2 = a^2 - a^2e^2 = 18 - 9 = 9$$

$$\therefore \text{Latus rectum} = \frac{2b^2}{a} = \frac{2 \times 9}{3\sqrt{2}} = 3\sqrt{2}$$

Question285

If $3x + 4y = 12\sqrt{2}$ is a tangent to the ellipse $\frac{x^2}{a^2} + \frac{y^2}{9} = 1$ for some $a \in \mathbb{R}$, then the distance between the foci of the ellipse is:
[Jan. 7, 2020 (II)]

Options:

A. $2\sqrt{7}$

B. 4

C. $2\sqrt{5}$

D. $2\sqrt{2}$

Answer: A

Solution:

Solution:

$$3x + 4y = 12\sqrt{2}$$

$$\Rightarrow 4y = -3x + 12\sqrt{2}$$

$$\Rightarrow y = -\frac{3}{4}x + 3\sqrt{2}$$

Now, condition of tangency, $c^2 = a^2m^2 + b^2$

$$18 = a^2 \cdot \frac{9}{16} + 9 \Rightarrow a^2 \cdot \frac{9}{16} = 9$$

$$\Rightarrow a^2 = 16 \Rightarrow a = 4$$

$$\text{Eccentricity } e = \sqrt{1 - \frac{b^2}{a^2}} = \sqrt{1 - \frac{9}{16}} = \frac{\sqrt{7}}{4}$$

$$\therefore ae = \frac{\sqrt{7}}{4} \cdot 4 = \sqrt{7}$$

$$\therefore \text{Focus are } (\pm\sqrt{7}, 0)$$

$$\therefore \text{Distance between foci of ellipse} = 2\sqrt{7}$$

Question286

If the length of the chord of the circle, $x^2 + y^2 = r^2$ ($r > 0$) along the line, $y - 2x = 3$ is r , then r^2 is equal to :
[Sep. 05, 2020 (II)]

Options:

- A. $\frac{9}{5}$
- B. 12
- C. $\frac{24}{5}$
- D. $\frac{12}{5}$

Answer: D

Solution:

Solution:

In right $\triangle RSQ$, $\sin 60^\circ = \frac{RS}{r}$

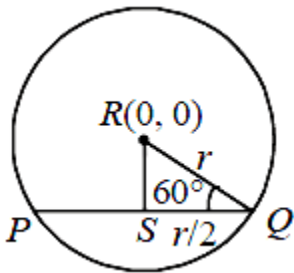

$$\Rightarrow RS = r \times \frac{\sqrt{3}}{2} = \frac{\sqrt{3}r}{2}$$

Now equation of PQ is $y - 2x - 3 = 0$

$$\therefore \frac{\sqrt{3}r}{2} = \frac{|0 + 0 - 3|}{\sqrt{5}}$$

$$\Rightarrow \frac{\sqrt{3}r}{2} = \frac{3}{\sqrt{5}} \Rightarrow r = \frac{2\sqrt{3}}{5} \Rightarrow r^2 = \frac{12}{5}$$

Question287

The circle passing through the intersection of the circles, $x^2 + y^2 - 6x = 0$ and $x^2 + y^2 - 4y = 0$, having its centre on the line, $2x - 3y + 12 = 0$, also passes through the point:
[Sep. 04, 2020 (II)]

Options:

A. (-1,3)

B. (-3,6)

C. (-3,1)

D. (1,-3)

Answer: B

Solution:

Solution:

We know family of circle be $S_1 + \lambda S_2 = 0$

$$x^2 + y^2 - 6x + \lambda(x^2 + y^2 - 4y) = 0$$

$$\Rightarrow (1 + \lambda)x^2 + (1 + \lambda)y^2 - 6x - 4\lambda y = 0 \dots (i)$$

$$\text{Centre } (-g, -f) = \left(\frac{3}{1 + \lambda}, \frac{2\lambda}{\lambda + 1} \right)$$

Centre lies on $2x - 3y + 12 = 0$, then

$$\frac{6}{\lambda + 1} - \frac{6\lambda}{\lambda + 1} + 12 = 0 \Rightarrow \lambda = -3$$

Equation of circle (i),

$$-2x^2 - 2y^2 - 6x + 12y = 0$$

$$\Rightarrow x^2 + y^2 + 3x - 6y = 0 \dots (ii)$$

Only (-3,6) satisfy equation (ii).

Question288

Let PQ be a diameter of the circle $x^2 + y^2 = 9$. If α and β are the lengths of the perpendiculars from P and Q on the straight line, $x + y = 2$ respectively, then the maximum value of $\alpha\beta$ is _____.

[NA Sep. 04, 2020 (II)]

Answer: 7

Solution:

Solution:

Let $P(3 \cos \theta, 3 \sin \theta)$, $Q(-3 \cos \theta, -3 \sin \theta)$

$$\alpha = \left| \frac{3 \cos \theta + 3 \sin \theta - 2}{\sqrt{2}} \right|, \beta = \left| \frac{-3 \cos \theta - 3 \sin \theta - 2}{\sqrt{2}} \right|$$

$$\alpha\beta = \left| \frac{(3 \cos \theta + 3 \sin \theta)^2 - 4}{2} \right| = \left| \frac{5 + 9 \sin 2\theta}{2} \right|$$

$\alpha\beta$ is max. when $\sin 2\theta = 1$

$$\therefore \alpha\beta|_{\max} = \frac{5+9}{2} = 7$$

Question289

The diameter of the circle, whose centre lies on the line $x + y = 2$ in the first quadrant and which touches both the lines $x = 3$ and $y = 2$, is

[NA Sep. 03, 2020 (I)]

Answer: 3

Solution:

Solution:

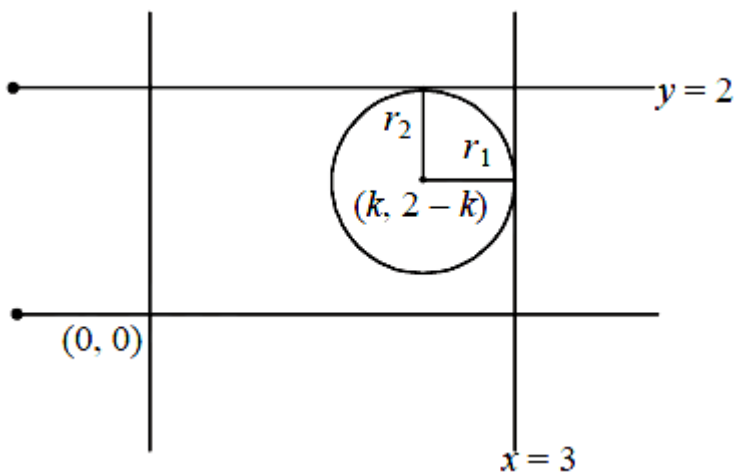

$$\Rightarrow \text{Radius } (r_1) = 3 - k$$

\because Centre lies on $x + y = 2$

Let $x = k$

$$\therefore y = 2 - k$$

$$\Rightarrow \text{Centre} = (k, 2 - k)$$

Also, radius (r_2) = $2 - (2 - k)$

$$\therefore 3 - k = 2 - (2 - k)$$

$$\Rightarrow k = \frac{3}{2}$$

$$r = 3 - \frac{3}{2} = \frac{3}{2}$$

Hence, diameter = 3.

Question290

The number of integral values of k for which the line, $3x + 4y = k$ intersects the circle, $x^2 + y^2 - 2x - 4y + 4 = 0$ at two distinct points is

[NA Sep. 02, 2020 (I)]

Answer: 9

Solution:

Solution:

The given circle is $x^2 + y^2 - 2x - 4y + 4 = 0$

\therefore Centre of circle (1, 2), $r = 1$

If line cuts circle then $p < r$, where $p = \left| \frac{ax_1 + by_1 + c}{\sqrt{a^2 + b^2}} \right|$

$$\Rightarrow \left| \frac{3 + 8 - k}{5} \right| < 1 \Rightarrow k \in (6, 16)$$

$k = 7, 8, 9, 10, 11, 12, 13, 14, 15$

Question291

Let L_1 be a tangent to the parabola $y^2 = 4(x + 1)$ and L_2 be a tangent to the parabola $y^2 = 8(x + 2)$ such that L_1 and L_2 intersect at right angles.

Then L_1 and L_2 meet on the straight line :

[Sep. 06, 2020 (I)]

Options:

A. $x + 3 = 0$

B. $2x + 1 = 0$

C. $x + 2 = 0$

D. $x + 2y = 0$

Answer: A

Solution:

Solution:

$$L_1 : y = m_1(x + 1) + \frac{1}{m_1} \left[\text{Tangent to } y^2 = 4(x + 1) \right]$$

$$L_2 : y = m_2(x + 2) + \frac{2}{m_2} \left[\text{Tangent to } y^2 = 8(x + 2) \right]$$

$$m_1^2(x + 1) - ym_1 + 1 = 0 \dots (i)$$

$$m_2^2(x + 2) - ym_2 + 2 = 0 \dots (ii)$$

$$\therefore m_2 = -\frac{1}{m_1} \quad (\because L_1 \perp L_2)$$

$$[\text{From(ii)}] \Rightarrow 2m_1^2 + ym_1 + (x + 2) = 0 \dots (iii)$$

From (i) and (iii),

$$\frac{x + 1}{2} = \frac{-y}{y} = \frac{1}{x + 2} \Rightarrow x + 3 = 0$$

Question292

The centre of the circle passing through the point (0,1) and touching the parabola $y = x^2$ at the point (2,4) is:

[Sep. 06, 2020 (II)]

Options:

A. $\left(\frac{-53}{10}, \frac{16}{5} \right)$

B. $\left(\frac{6}{5}, \frac{53}{10} \right)$

C. $\left(\frac{3}{10}, \frac{16}{5} \right)$

D. $\left(\frac{-16}{5}, \frac{53}{10} \right)$

Answer: D

Solution:

Solution:

Circle passes through A(0, 1) and B(2, 4). So its centre is the point of intersection of perpendicular bisector of AB and normal to the parabola at (2,4) .

Perpendicular bisector of AB;

$$y - \frac{5}{2} = -\frac{2}{3}(x - 1) \Rightarrow 4x + 6y = 19 \dots (i)$$

Equation of normal to the parabola at (2,4) is,

$$y - 4 = -\frac{1}{4}(x - 2) \Rightarrow x + 4y = 18 \dots (ii)$$

$$\therefore \text{From (i) and (ii), } x = -\frac{16}{5}, y = \frac{53}{10}$$

$$\therefore \text{Centre of the circle is } \left(-\frac{16}{5}, \frac{53}{10} \right)$$

Question293

If the common tangent to the parabolas, $y^2 = 4x$ and $x^2 = 4y$ also touches the circle, $x^2 + y^2 = c^2$, then c is equal to:

[Sep. 05, 2020 (I)]

Options:

A. $\frac{1}{2\sqrt{2}}$

B. $\frac{1}{\sqrt{2}}$

C. $\frac{1}{4}$

D. $\frac{1}{2}$

Answer: B

Solution:

Solution:

Equation tangent to parabola $y^2 = 4x$ with slope m be:

$$y = mx + \frac{1}{m} \dots (i)$$

\therefore Equation of tangent to $x^2 = 4y$ with slope m be :

$$y = mx - am^2 \dots (ii)$$

From eq. (i) and (ii), $\frac{1}{m} = -m^2 \Rightarrow m = -1$

\therefore Equation tangent : $x + y + 1 = 0$

It is tangent to circle $x^2 + y^2 = c^2$

$$\Rightarrow c = \frac{1}{\sqrt{2}}$$

Question294

Let P be a point on the parabola, $y^2 = 12x$ and N be the foot of the perpendicular drawn from P on the axis of the parabola. A line is now drawn through the mid-point M of PN, parallel to its axis which meets the parabola at Q. If the y-intercept of the line NQ is $\frac{4}{3}$, then :
[Sep. 03, 2020 (I)]

Options:

A. $PN = 4$

B. $MQ = \frac{1}{3}$

C. $MQ = \frac{1}{4}$

D. $PN = 3$

Answer: C

Solution:

Solution:

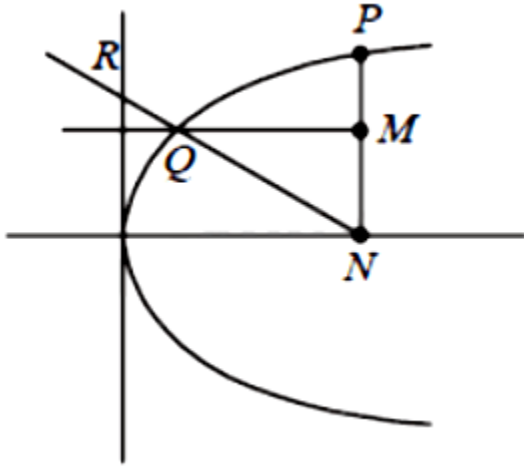

$$\because y^2 = 12x$$

$$\therefore a = 3$$

$$\text{Let } P(at^2, 2at)$$

$$\Rightarrow N(at^2, 0) \Rightarrow M(at^2, at)$$

$$\because \text{Equation of } QM \text{ is } y = at$$

$$\text{So, } y^2 = 4ax \Rightarrow x = \frac{at^2}{4}$$

$$\Rightarrow Q\left(\frac{at^2}{4}, at\right)$$

$$y = \frac{-4}{3t}(x - at^2)$$

$$\because QN \text{ passes through } \left(0, \frac{4}{3}\right), \text{ then}$$

$$\frac{4}{3} = -\frac{4}{3t}(-at^2) \Rightarrow at = 1 \Rightarrow t = \frac{1}{3}$$

$$\text{Now, } MQ = \frac{3}{4}at^2 = \frac{1}{4} \text{ and } PN = 2at = 2$$

Question295

Let the latus ractum of the parabola $y^2 = 4x$ be the common chord to the circles C_1 and C_2 each of them having radius $2\sqrt{5}$. Then, the

distance between the centres of the circles C_1 and C_2 is :

[Sep. 03, 2020 (II)]

Options:

A. $8\sqrt{5}$

B. 8

C. 12

D. $4\sqrt{5}$

Answer: B

Solution:

Solution:

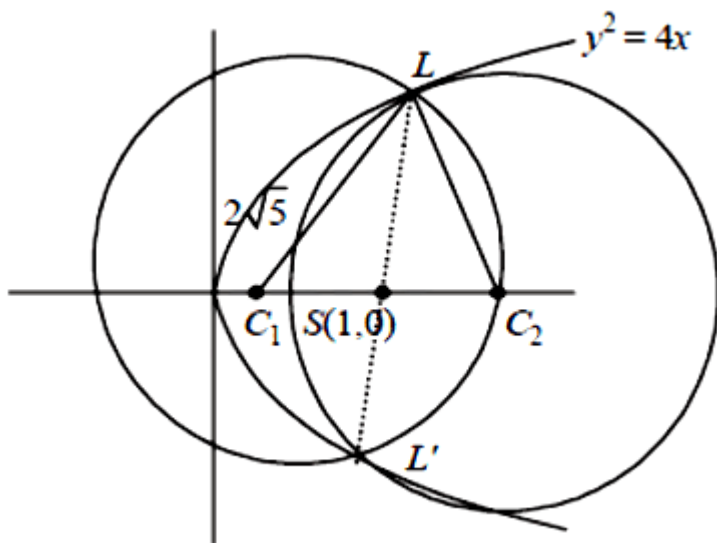

Distance between the centres
 $= C_1C_2 = 2C_1S = 2\sqrt{20-4} = 8$

Question296

The area (in sq. units) of an equilateral triangle inscribed in the parabola $y^2 = 8x$, with one of its vertices on the vertex of this parabola, is:

[Sep. 02, 2020 (II)]

Options:

A. $64\sqrt{3}$

B. $256\sqrt{3}$

C. $192\sqrt{3}$

D. $128\sqrt{3}$

Answer: C

Solution:

Solution:

Let $A = (2t^2, 4t)$ and $B = (2t^2, -4t)$

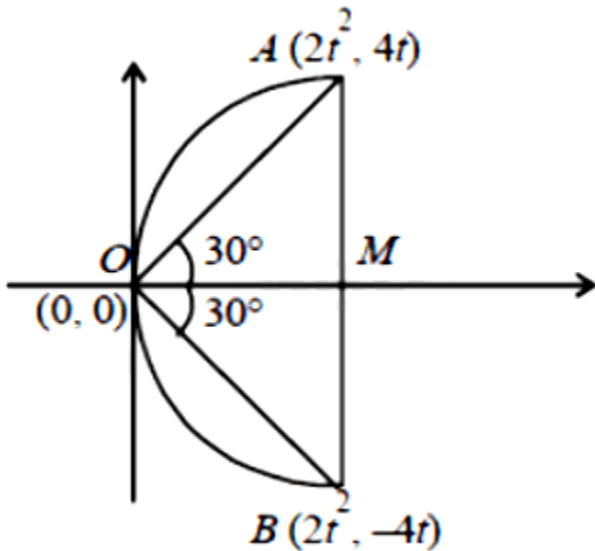

For equilateral triangle ($\angle AOM = 30^\circ$)

$$\tan 30^\circ = \frac{4t}{2t^2} \Rightarrow \frac{1}{\sqrt{3}} = \frac{4t}{2t^2} \Rightarrow t = 2\sqrt{3}$$

$$\text{Area} = \frac{1}{2} \cdot 8(2\sqrt{3}) \cdot 2 \cdot 24 = 192\sqrt{3}$$

Question297

Which of the following points lies on the locus of the foot of perpendicular drawn upon any tangent to the ellipse, $\frac{x^2}{4} + \frac{y^2}{2} = 1$ from

any of its foci?
[Sep. 06, 2020 (I)]

Options:

A. $(-2, \sqrt{3})$

B. $(-1, \sqrt{2})$

C. $(-1, \sqrt{3})$

D. $(1, 2)$

Answer: C

Solution:

Solution:

We know that the locus of the feet of the perpendicular draw from foci to any tangent of the ellipse

$$\frac{x^2}{a^2} + \frac{y^2}{b^2} = 1 \text{ is the auxiliary circle } x^2 + y^2 = a^2$$

$$\therefore \text{Auxiliary circle : } x^2 + y^2 = 4$$

$(-1, \sqrt{3})$ satisfies the given equation.

Question298

If the normal at an end of a latus rectum of an ellipse passes through an extremity of the minor axis, then the eccentricity e of the ellipse satisfies:

[Sep. 06, 2020 (II)]

Options:

A. $e^4 + 2e^2 - 1 = 0$

B. $e^2 + e - 1 = 0$

C. $e^4 + e^2 - 1 = 0$

D. $e^2 + 2e - 1 = 0$

Answer: C

Solution:

Solution:

Normal to the ellipse $\frac{x^2}{a^2} + \frac{y^2}{b^2} = 1$ at $\left(ae, \frac{b^2}{a} \right)$ is

$$\frac{a^2x}{ae} - \frac{b^2y}{b^2/a} = a^2 - b^2$$

$$\Rightarrow x - ey = \frac{e(a^2 - b^2)}{a}$$

$\therefore (0, -b)$ lies on equation (i), then

$$be = \frac{e(a^2 - b^2)}{a}$$

$$\Rightarrow ab = a^2e^2 \Rightarrow b = ae^2 \Rightarrow \frac{b^2}{a^2} = e^4$$

$$\therefore 1 - e^2 = e^4 \Rightarrow e^4 + e^2 - 1 = 0$$

Question299

If the co-ordinates of two points A and B are $(\sqrt{7}, 0)$ and $(-\sqrt{7}, 0)$ respectively and P is any point on the conic, $9x^2 + 16y^2 = 144$, then

PA + PB is equal to :

[Sep. 05, 2020 (I)]

Options:

A. 16

B. 8

C. 6

D. 9

Answer: B

Solution:

Ellipse: $\frac{x^2}{16} + \frac{y^2}{9} = 1,$

$a = 4, b = 3, c = \sqrt{16 - 9} = \sqrt{7}$

$\therefore (\pm\sqrt{7}, 0)$ are the foci of given ellipse. So for any point P on it; $PA + PB = 2a$

$\Rightarrow PA + PB = 2(4) = 8$

Question300

If the point P on the curve, $4x^2 + 5y^2 = 20$ is farthest from the point

Q(0, -4), then PQ^2 is equals to :

[Sep. 05, 2020 (I)]

Options:

A. 36

B. 48

C. 21

D. 29

Answer: A

Solution:

Ellipse $\equiv \frac{x^2}{5} + \frac{y^2}{4} = 1$

Let a point on ellipse be $(\sqrt{5} \cos \theta, 2 \sin \theta)$

$\therefore PQ^2 = (\sqrt{5} \cos \theta)^2 + (-4 - 2 \sin \theta)^2$

$= 5 \cos^2 \theta + 4 \sin^2 \theta + 16 + 16 \sin \theta$

$= 21 + 16 \sin \theta - \sin^2 \theta$

$= 21 + 64 - (\sin \theta - 8)^2 = 85 - (\sin \theta - 8)^2$

PQ^2 to be maximum when $\sin \theta = 1$

$PQ_{\max}^2 = 85 - 49 = 36$

Question301

Let $\frac{x^2}{a^2} + \frac{y^2}{b^2} = 1$ ($a > b$) be a given ellipse, length of whose latus rectum is 10. If its eccentricity is the maximum value of the function, $\varphi(t) = \frac{5}{12} + t - t^2$, then $a^2 + b^2$ is equal to:
[Sep. 04, 2020 (I)]

Options:

- A. 145
- B. 116
- C. 126
- D. 135

Answer: C

Solution:

Solution:

The given ellipse is

$$\frac{x^2}{a^2} + \frac{y^2}{b^2} = 1, (a > b)$$

$$\text{Length of latus rectum} = \frac{2b^2}{a}$$

$$\Rightarrow \frac{2b^2}{a} = 10 \Rightarrow b^2 = 5a \dots \dots (i)$$

$$\text{Now } \varphi(t) = \frac{5}{12} + t - t^2$$

$$\varphi'(t) = 1 - 2t = 0 \Rightarrow t = \frac{1}{2}$$

$$\varphi''(t) = -2 < 0 \Rightarrow \text{maximum}$$

$$\Rightarrow \varphi(t)_{\max} = \frac{5}{12} + \frac{1}{2} - \frac{1}{4} = \frac{8}{12} = \frac{2}{3}$$

Since, $\varphi(t)_{\max} = \text{eccentricity}$

$$\Rightarrow e = \frac{2}{3}$$

Now, $b^2 = a^2(1 - e^2)$

$$5a = a^2 \left(1 - \frac{4}{9}\right) \Rightarrow 5a = \frac{5a^2}{9} \Rightarrow a^2 - 9a = 0$$

$$\Rightarrow a = 9 \Rightarrow a^2 = 81 \text{ and } b^2 = 45$$

$$\therefore a^2 + b^2 = 81 + 45 = 126$$

Question302

Let $x = 4$ be a directrix to an ellipse whose centre is at the origin and its eccentricity is $\frac{1}{2}$. If $P(1, \beta)$, $\beta > 0$ is a point on this ellipse, then the equation of the normal to it at P is :

[Sep. 04, 2020 (II)]

Options:

A. $4x - 3y = 2$

B. $8x - 2y = 5$

C. $7x - 4y = 1$

D. $4x - 2y = 1$

Answer: D

Solution:

Solution:

$$\frac{a}{e} = 4 \Rightarrow a = 4 \times \frac{1}{2} = 2$$

Now, $b^2 = a^2(1 - e^2)$

$$\Rightarrow b^2 = 4 \left(1 - \frac{1}{4}\right) = 4 \times \frac{3}{4} = 3$$

So, equation $\frac{x^2}{4} + \frac{y^2}{3} = 1$

$$\Rightarrow 3x^2 + 4y^2 = 12 \dots (i)$$

Now, $P(1, \beta)$ lies on it

$$\Rightarrow 3 + 4\beta^2 = 12 \Rightarrow \beta = \frac{3}{2}$$

So, equation of normal at $P\left(1, \frac{3}{2}\right)$

$$\Rightarrow \frac{a^2x}{1} - \frac{b^2y}{3/2} = a^2 - b^2 \Rightarrow 4x - 2y = 1$$

Question303

A hyperbola having the transverse axis of length $\sqrt{2}$ has the same foci as that of the ellipse $3x^2 + 4y^2 = 12$, then this hyperbola does not pass through which of the following points?

[Sep. 03, 2020 (I)]

Options:

- A. $\left(\frac{1}{\sqrt{2}}, 0\right)$
- B. $\left(-\sqrt{\frac{3}{2}}, 1\right)$
- C. $\left(1, -\frac{1}{\sqrt{2}}\right)$
- D. $\left(\sqrt{\frac{3}{2}}, \frac{1}{\sqrt{2}}\right)$

Answer: D

Solution:

Solution:

The given ellipse:

$$\frac{x^2}{4} + \frac{y^2}{3} = 1$$

$$\therefore c = \sqrt{a^2 - b^2} = \sqrt{4 - 3} = 1$$

\therefore Foci = $(\pm 1, 0)$

Now for hyperbola:

$$\text{Given: } 2a = \sqrt{2} \Rightarrow a = \frac{1}{\sqrt{2}}$$

$$\because c^2 = a^2 + b^2 \Rightarrow 1 = \frac{1}{2} + b^2 \Rightarrow b = \frac{1}{\sqrt{2}}$$

So, equation of hyperbola is

$$\frac{x^2}{\frac{1}{2}} - \frac{y^2}{\frac{1}{2}} = 1$$

$$\Rightarrow 2x^2 - 2y^2 = 1$$

So, option (d) does not satisfy it.

Question304

Area (in sq. units) of the region outside $\frac{|x|}{2} + \frac{|y|}{3} = 1$ and inside the ellipse $\frac{x^2}{4} + \frac{y^2}{9} = 1$ is:

[Sep. 02, 2020 (I)]

Options:

A. $6(\pi - 2)$

B. $3(\pi - 2)$

C. $3(4 - \pi)$

D. $6(4 - \pi)$

Answer: A

Solution:

Solution:

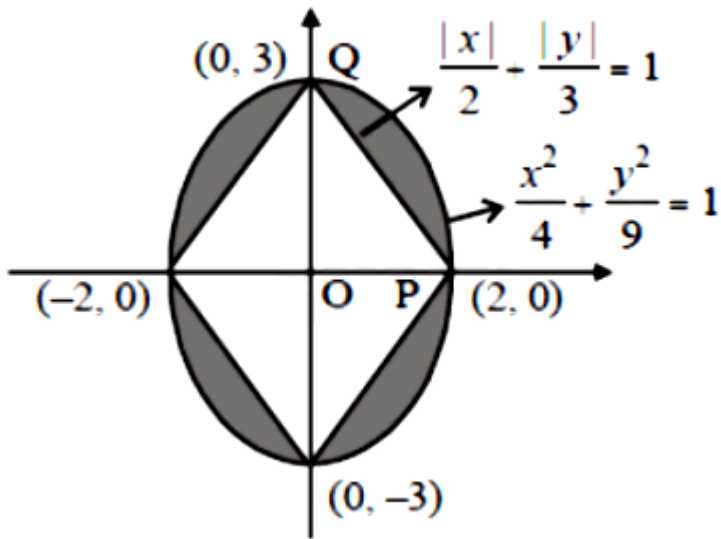

$$\because \text{Area of ellipse} = \pi ab = \pi \times 2 \times 3 = 6\pi$$

Required area = Area of ellipse

- 4 (Area of triangle OPQ)

$$= 6\pi - 4 \left(\frac{1}{2} \times 2 \times 3 \right)$$

$$= 6\pi - 12 = 6(\pi - 2) \text{ sq. units}$$

Question305

If the line $y = mx + c$ is a common tangent to the hyperbola $\frac{x^2}{100} - \frac{y^2}{64} = 1$ and the circle $x^2 + y^2 = 36$, then which one of the following is true?
[Sep. 05, 2020 (II)]

Options:

A. $c^2 = 369$

B. $5m = 4$

C. $4c^2 = 369$

D. $8m + 5 = 0$

Answer: C

Solution:

Solution:

General tangent to hyperbola in slope form is $y = mx \pm \sqrt{100m^2 - 64}$

and the general tangent to the circle in slope form is $y = mx \pm 6\sqrt{1+m^2}$

For common tangent,

$$36(1+m^2) = 100m^2 - 64$$

$$\Rightarrow 100 = 64m^2 \Rightarrow m^2 = \frac{100}{64}$$

$$\therefore c^2 = 36\left(1 + \frac{100}{64}\right) = \frac{164 \times 36}{64} = \frac{369}{4}$$

$$\Rightarrow 4c^2 = 369$$

Question306

Let $P(3, 3)$ be a point on the hyperbola, $\frac{x^2}{a^2} - \frac{y^2}{b^2} = 1$. If the normal to it at P intersects the x -axis at $(9,0)$ and e is its eccentricity, then the ordered pair (a^2, e^2) is equal to :

[Sep. 04, 2020 (I)]

Options:

A. $\left(\frac{9}{2}, 3\right)$

B. $\left(\frac{3}{2}, 2\right)$

C. $\left(\frac{9}{2}, 2\right)$

D. $(9,3)$

Answer: A

Solution:**Solution:**

\therefore The equation of hyperbola is $\frac{x^2}{a^2} - \frac{y^2}{b^2} = 1$

\therefore Equation of hyperbola passes through $(3,3)$

$$\frac{1}{a^2} - \frac{1}{b^2} = \frac{1}{9} \dots (i)$$

Equation of normal at point (3,3) is:

$$\frac{x-3}{\frac{1}{a^2} \cdot 3} = \frac{y-3}{-\frac{1}{b^2} \cdot 3}$$

∴ It passes through (9,0)

$$\frac{6}{\frac{1}{a^2}} = \frac{-3}{-\frac{1}{b^2}}$$

$$\frac{1}{b^2} = \frac{1}{2a^2} \dots (ii)$$

From equations (i) and (ii),

$$a^2 = \frac{9}{2}, b^2 = 9$$

$$\therefore \text{Eccentricity} = e, \text{ then } e^2 = 1 + \frac{b^2}{a^2} = 3$$

$$\therefore (a^2, e^2) = \left(\frac{9}{2}, 3 \right)$$

Question307

Let e_1 and e_2 be the eccentricities of the ellipse, $\frac{x^2}{25} + \frac{y^2}{b^2} = 1$ ($b < 5$) and the hyperbola, $\frac{x^2}{16} - \frac{y^2}{b^2} = 1$ respectively satisfying $e_1 e_2 = 1$. If α and β are the distances between the foci of the ellipse and the foci of the hyperbola respectively, then the ordered pair (α, β) is equal to :
[Sep. 03, 2020 (II)]

Options:

A. (8,12)

B. $\left(\frac{20}{3}, 12 \right)$

C. $\left(\frac{24}{5}, 10 \right)$

D. (8,10)

Answer: B

Solution:

Solution:

Equation of ellipse is $\frac{x^2}{25} + \frac{y^2}{b^2} = 1$

Then, $e_1 = \sqrt{1 - \frac{b^2}{25}}$

The equation of hyperbola, $\frac{x^2}{16} - \frac{y^2}{b^2} = 1$

Then, $e_2 = \sqrt{1 + \frac{b^2}{16}}$ $G_1 e_2 = 1$

$$\Rightarrow (e_1 e_2)^2 = 1 \Rightarrow \left(1 - \frac{b^2}{25}\right) \left(1 + \frac{b^2}{16}\right) = 1$$

$$\Rightarrow 1 + \frac{b^2}{16} - \frac{b^2}{25} - \frac{b^4}{25 \times 16} = 1$$

$$\Rightarrow \frac{9}{16 \cdot 25} b^2 - \frac{b^4}{25 \cdot 16} = 0 \Rightarrow b^2 = 9$$

$$\therefore e_1 = \sqrt{1 - \frac{9}{25}} = \frac{4}{5}$$

$$\text{And, } e_2 = \sqrt{1 + \frac{9}{16}} = \frac{5}{4}$$

Distance between foci of ellipse

$$= \alpha = 2ae_1 = 2(5)(e_1) = 8$$

Distance between foci of hyperbola

$$= \beta = 2ae_2 = 2(4)(e_2) = 10$$

$$\therefore (\alpha, \beta) = (8, 10)$$

Question308

A line parallel to the straight line $2x - y = 0$ is tangent to the hyperbola

$\frac{x^2}{4} - \frac{y^2}{2} = 1$ at the point (x_1, y_1) . Then $x_1^2 + 5y_1^2$ is equal to :

[Sep. 02, 2020 (I)]

Options:

A. 6

B. 8

C. 10

D. 5

Answer: A

Solution:

Solution:

The tangent to the hyperbola at the point (x_1, y_1) is,

$$xx_1 - 2yy_1 - 4 = 0$$

The given equation of tangent is

$$2x - y = 0$$

$$\Rightarrow \frac{x_1}{2y_1} = 2$$

$$\Rightarrow x_1 = 4y_1 \dots (i)$$

Since, point (x_1, y_1) lie on hyperbola.

$$\therefore \frac{x_1^2}{4} - \frac{y_1^2}{2} - 1 = 0$$

On solving eqs. (i) and (ii)

$$y_1^2 = \frac{2}{7}, x_1^2 = \frac{32}{7}$$

$$\therefore x_1^2 + 5y_1^2 = \frac{32}{7} + 5 \times \frac{2}{7} = 6$$

Question309

For some $\theta \in \left(0, \frac{\pi}{2}\right)$, if the eccentricity of the hyperbola,

$x^2 - y^2 \sec^2 \theta = 10$ is $\sqrt{5}$ times the eccentricity of the ellipse,

$x^2 \sec^2 \theta + y^2 = 5$, then the length of the latus rectum of the ellipse, is:
[Sep. 02, 2020 (II)]

Options:

A. $2\sqrt{6}$

B. $\sqrt{30}$

C. $\frac{2\sqrt{5}}{3}$

D. $\frac{4\sqrt{5}}{3}$

Answer: D

Solution:

Solution:

Hyperbola: $\frac{x^2}{10} - \frac{y^2}{10\cos^2\theta} = 1 \Rightarrow e_1 = \sqrt{1 + \cos^2\theta}$ and Ellipse: $\frac{x^2}{5\cos^2\theta} + \frac{y^2}{5} = 1$

$\Rightarrow e_2 = \sqrt{1 - \cos^2\theta} = \sin\theta$

According to the question, $q_1 = \sqrt{5}e_2$

$\Rightarrow 1 + \cos^2\theta = 5\sin^2\theta \Rightarrow \cos^2\theta = \frac{2}{3}$

Now length of latus rectum of ellipse

$= \frac{2a^2}{b} = \frac{10\cos^2\theta}{\sqrt{5}} = \frac{20}{3\sqrt{5}} = \frac{4\sqrt{5}}{3}$

Question310

If a circle of radius R passes through the origin O and intersects the coordinate axes at A and B, then the locus of the foot of perpendicular from O on AB is

[Jan. 12, 2019 (II)]

Options:

A. $(x^2 + y^2)^2 = 4R^2x^2y^2$

B. $(x^2 + y^2)^3 = 4R^2x^2y^2$

C. $(x^2 + y^2)^2 = 4Rx^2y^2$

D. $(x^2 + y^2)(x + y) = R^2xy$

Answer: B

Solution:

As $\angle AOB = 90^\circ$

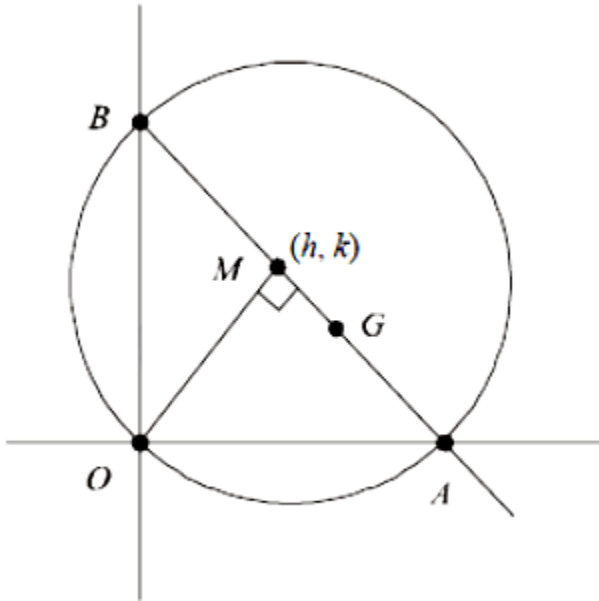

Let AB diameter and M (h, k) be foot of perpendicular, then

$M_{AB} = \frac{-h}{k}$ Then, equation of AB

$$(y - k) = \frac{-h}{k}(x - h)$$

$$\Rightarrow hx + ky = h^2 + k^2$$

Then, A $\left(\frac{h^2 + k^2}{h}, 0 \right)$ and B $\left(0, \frac{h^2 + k^2}{k} \right)$

\because AB is the diameter, then $AB = 2R$

$$\Rightarrow AB^2 = 4R^2$$

$$\Rightarrow \left(\frac{h^2 + k^2}{h} \right)^2 + \left(\frac{h^2 + k^2}{k} \right)^2 = 4R^2$$

Hence, required locus is $(x^2 + y^2)^3 = 4R^2 x^2 y^2$

Question311

Let C_1 and C_2 be the centres of the circles $x^2 + y^2 - 2x - 2y - 2 = 0$ and $x^2 + y^2 - 6x - 6y + 14 = 0$ respectively. If P and Q are the points of intersection of these circles then, the area (in sq. units) of the quadrilateral PC_1QC_2 is :

[Jan. 12, 2019 (I)]

Options:

A. 8

B. 6

C. 9

D. 4

Answer: D

Solution:

Solution:

From question, the equations of the circles are:

$$x^2 + y^2 - 2x - 2y - 2 = 0$$

$$x^2 + y^2 - 6x - 6y + 14 = 0$$

The two circles are intersected orthogonally if $2g_1g_2 + 2f_1f_2 = c_1 + c_2$.

The above equations are intersecting each other orthogonally, because

$$\Rightarrow 2(1)(3) + 2(1)(3) = 14 - 2$$

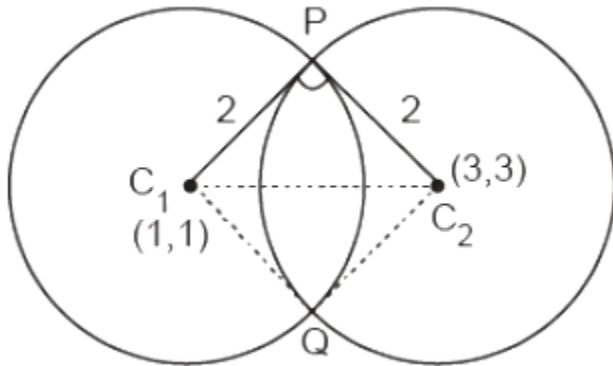

So, the area of quadrilateral PC_1QC_2 is given by the formula:

$$\Rightarrow A = 2 \times \text{ar}(\Delta PC_1C_2)$$

$$\Rightarrow A = 2 \times \left(\frac{1}{2} \times 2 \times 2 \right)$$

$$\therefore A = 4 \text{ sq units}$$

Question312

If a variable line, $3x + 4y - \lambda = 0$ is such that the two circles $x^2 + y^2 - 2x - 2y + 1 = 0$ and $x^2 + y^2 - 18x - 2y + 78 = 0$ are on its opposite sides, then the set of all values of λ is the interval :
[Jan. 12, 2019 (I)]

Options:

A. (2,17)

B. [13,23]

C. [12,21]

D. (23,31)

Answer: C

Solution:

Solution:

Condition 1: The centre of the two circles are (1,1) and (9,1) . The circles are on opposite sides of the line

$$3x + 4y - \lambda = 0$$

Put $x = 1, y = 1$ in the equation of line,

$$3(1) + 4(1) - \lambda = 0 \Rightarrow 7 - \lambda = 0$$

Now, put $x = 9, y = 1$ in the equation of line,

$$3(9) + 4(1) - \lambda = 0$$

Then, $(7 - \lambda)(27 + 4 - \lambda) < 0$

$$\Rightarrow (\lambda - 7)(\lambda - 31) < 0$$

$$\lambda \in (7, 31) \dots (i)$$

Condition 2: Perpendicular distance from centre on line \geq radius of circle.

For $x^2 + y^2 - 2x - 2y = 1$,

$$\Rightarrow \frac{|3 + 4 - \lambda|}{5} \geq 1$$

$$\Rightarrow |\lambda - 7| \geq 5$$

$$\Rightarrow \lambda \geq 12 \text{ or } \lambda \leq 2 \dots (ii)$$

For $x^2 + y^2 - 18x - 2y + 78 = 0$

$$\frac{|27 + 4 - \lambda|}{5} \geq 2$$

$$\Rightarrow \lambda \geq 41 \text{ or } \lambda \leq 21 \dots (iii)$$

Intersection of (1),(2) and (3) gives $\lambda \in [12, 21]$

Question313

A square is inscribed in the circle $x^2 + y^2 - 6x + 8y - 103 = 0$ with its sides parallel to the coordinate axes. Then the distance of the vertex of this square which is nearest to the origin is :

[Jan. 11, 2019 (I)]

Options:

A. 6

B. $\sqrt{137}$

C. $\sqrt{41}$

D. 13

Answer: C

Solution:

Solution:

The equation of circle is,

$$x^2 + y^2 - 6x + 8y - 103 = 0$$

$$\Rightarrow (x - 3)^2 + (y + 4)^2 = (8\sqrt{2})^2$$

$$C(3, -4), r = 8\sqrt{2}$$

$$\Rightarrow \text{Length of side of square} = \sqrt{2}r = 16$$

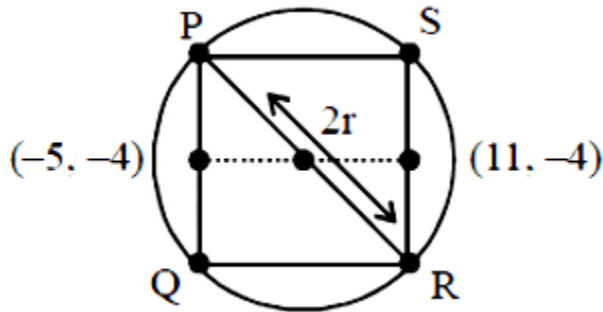

$$\Rightarrow P(-5, 4), Q(-5, -12)$$

$$R(11, -12), S(11, 4)$$

$$\Rightarrow \text{Required distance} = OP$$

$$= \sqrt{(-5 - 0)^2 + (-4 - 0)^2} = \sqrt{25 + 16} = \sqrt{41}$$

Question314

Two circles with equal radii are intersecting at the points $(0,1)$ and $(0,-1)$. The tangent at the point $(0,1)$ to one of the circles passes through the centre of the other circle. Then the distance between the centres of these circles is :

[Jan. 11, 2019 (I)]

Options:

A. 1

B. 2

C. $2\sqrt{2}$

D. $\sqrt{2}$

Answer: B

Solution:

Solution:

(b) \because Two circles of equal radii intersect each other orthogonally. Then R is mid point of PQ.

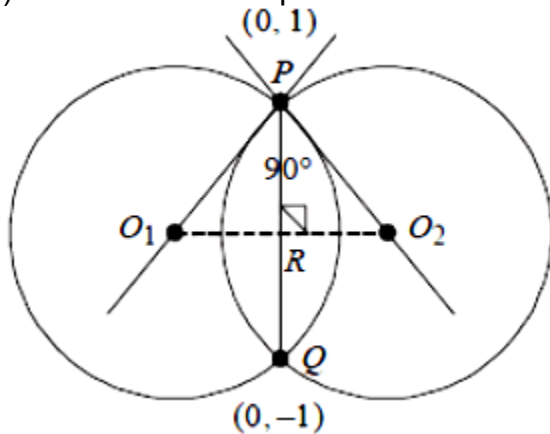

and $PR = O_1R = O_2R$

$$PR = \frac{1}{2} \sqrt{(0-0)^2 + (1+1)^2} = 1$$

\therefore Distance between centres = $1 + 1 = 2$

Question315

A circle cuts a chord of length 4 a on the x -axis and passes through a point on the y -axis, distant 2b from the origin. Then the locus of the centre of this circle, is :

[Jan. 11, 2019 (II)]

Options:

A. a hyperbola

B. an ellipse

C. a straight line

D. a parabola

Answer: D

Solution:

Solution:

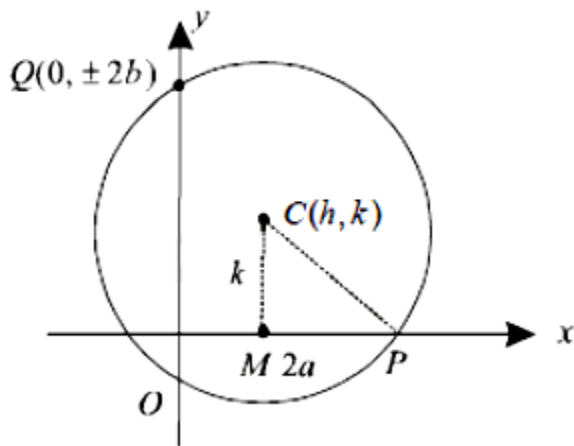

Let centre be $C(h, k)$

$CQ = CP = r$

$\Rightarrow CQ^2 = CP^2$

$(h - 0)^2 + (k \pm 0)^2 = CM^2 + MP^2$

$h^2 + (k \pm 2b)^2 = k^2 + 4a^2$

$h^2 + k^2 + 4b^2 \pm 4bk = k^2 + 4a^2$

Then, the locus of centre $C(h, k)$

$x^2 + 4b^2 \pm 4by = 4a^2$

Hence, the above locus of the centre of circle is a parabola.

Question316

If a circle C passing through the point $(4,0)$ touches the circle $x^2 + y^2 + 4x - 6y = 12$ externally at the point $(1, -1)$, then the radius of C is:

[Jan 10, 2019 (I)]

Options:

A. $2\sqrt{5}$

B. 4

C. 5

D. $\sqrt{57}$

Answer: C

Solution:

Solution:

The equation of circle $x^2 + y^2 + 4x - 6y = 12$ can be written as $(x + 2)^2 + (y - 3)^2 = 25$

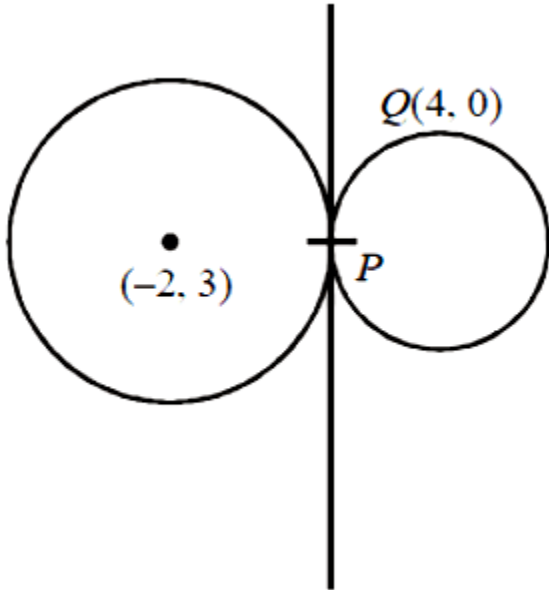

Let $P = (1, -1)$ & $Q = (4, 0)$

Equation of tangent at $P(1, -1)$ to the given circle :

$$x(1) + y(-1) + 2(x + 1) - 3(y - 1) - 12 = 0$$

$$3x - 4y - 7 = 0 \dots (i)$$

The required circle is tangent to (1) at $(1, -1)$

$$\therefore (x - 1)^2 + (y + 1)^2 + \lambda(3x - 4y - 7) = 0 \dots (ii)$$

Equation (ii) passes through $Q(4, 0)$

$$\Rightarrow 3^2 + 1^2 + \lambda(12 - 7) = 0 \Rightarrow 5\lambda + 10 = 0 \Rightarrow \lambda = -2$$

$$\text{Equation (2) becomes } x^2 + y^2 - 8x + 10y + 16 = 0 \text{ radius} = \sqrt{(-4)^2 + (5)^2 - 16} = 5$$

Question 317

If the area of an equilateral triangle inscribed in the circle, $x^2 + y^2 + 10x + 12y + c = 0$ is $27\sqrt{3}$ sq. units then c is equal to:

[Jan. 10, 2019 (II)]

Options:

A. 13

B. 20

C. -25

D. 25

Answer: D

Solution:

Solution:

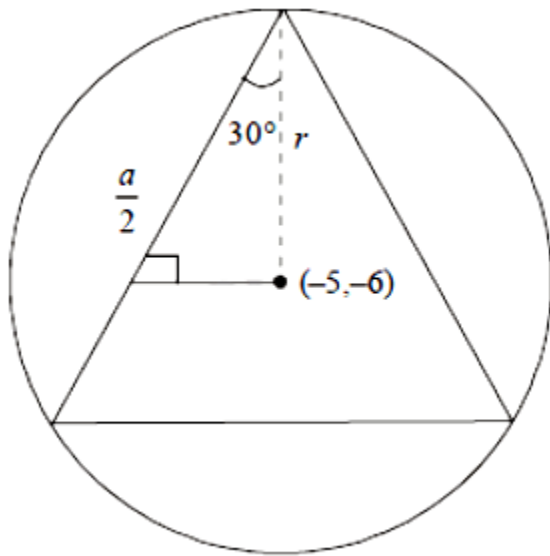

Let the sides of equilateral Δ inscribed in the circle be a then $\cos 30^\circ = \frac{a}{2r}$

$$\frac{\sqrt{3}}{2} = \frac{a}{2r} \Rightarrow a = \sqrt{3}r$$

Then, area of the equilateral triangle = $\frac{\sqrt{3}}{4}a^2$

$$= \frac{\sqrt{3}}{4}(\sqrt{3}r)^2 = \frac{3\sqrt{3}}{4}r^2$$

But it is given that area of equilateral triangle = $27\sqrt{3}$

$$\text{Then, } 27\sqrt{3} = \frac{3\sqrt{3}}{4}r^2$$

$$r^2 = 36 \Rightarrow r = 6$$

But $\left(-\frac{1}{2} \text{ coeff. of } x\right)^2 + \left(-\frac{1}{2} \text{ coeff. of } y\right)^2 - \text{constant term} = r^2$

$$(-5)^2 + (-6)^2 - c = 36 \Rightarrow c = 25$$

Question318

Three circles of radii a, b, c ($a < b < c$) touch each other externally. If they have x -axis as a common tangent, then:

[Jan 09, 2019 (I)]

Options:

A. $\frac{1}{\sqrt{a}} = \frac{1}{\sqrt{b}} + \frac{1}{\sqrt{c}}$

B. $\frac{1}{\sqrt{b}} = \frac{1}{\sqrt{a}} + \frac{1}{\sqrt{c}}$

C. a, b, c are in A.P

D. $\sqrt{a}, \sqrt{b}, \sqrt{c}$ are in A.P.

Answer: A

Solution:

Solution:

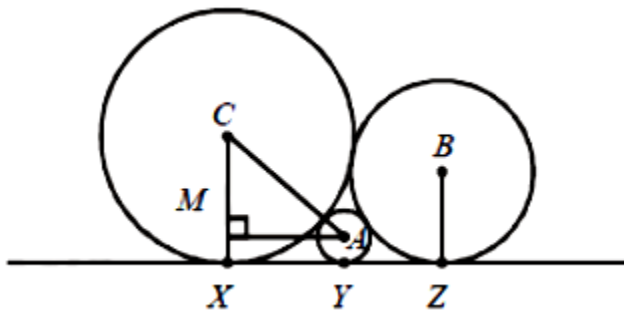

$$AM^2 = AC^2 - MC^2$$

$$= (a + c)^2 - (a - c)^2 = 4ac$$

$$\Rightarrow AM^2 = XY^2 = 4ac$$

$$\Rightarrow XY = 2\sqrt{ac}$$

Similarly, $YZ = 2\sqrt{ba}$ and $XZ = 2\sqrt{bc}$

Then, $XZ = XY + YZ$

$$\Rightarrow 2\sqrt{bc} = 2\sqrt{ac} + 2\sqrt{ba}$$

$$\Rightarrow \frac{1}{\sqrt{a}} = \frac{1}{\sqrt{b}} + \frac{1}{\sqrt{c}}$$

Question319

If the circles $x^2 + y^2 - 16x - 20y + 164 = r^2$ and $(x - 4)^2 + (y - 7)^2 = 36$ intersect at two distinct points, then:

[Jan. 09, 2019 (II)]

Options:

A. $r > 11$

B. $0 < r < 1$

C. $r = 11$

D. $1 < r < 11$

Answer: D

Solution:

Solution:

Consider the equation of circles as,

$$x^2 + y^2 - 16x - 20y + 164 = r^2$$

i.e. $(x - 8)^2 + (y - 10)^2 = r^2 \dots (i)$

and $(x - 4)^2 + (y - 7)^2 = 36 \dots (ii)$

Both the circles intersect each other at two distinct points. Distance between centres

$$= \sqrt{(8 - 4)^2 + (10 - 7)^2} = 5$$

$$\therefore |r - 6| < 5 < |r + 6| \dots (iii)$$

$$\therefore \text{If } |r - 6| < 5 \Rightarrow r \in (1, 11) \dots (iv)$$

$$\text{and } |r + 6| > 5 \Rightarrow r \in (-\infty, -11) \cup (-1, \infty)$$

From (iii) and (iv),

$$r \in (1, 11)$$

Question320

The straight line $x + 2y = 1$ meets the coordinate axes at A and B. A circle is drawn through A, B and the origin. Then the sum of perpendicular distances from A and B on the tangent to the circle at the origin is:

[Jan. 11, 2019 (I)]

Options:



A. $\frac{\sqrt{5}}{2}$

B. $2\sqrt{5}$

C. $\frac{\sqrt{5}}{4}$

D. $4\sqrt{5}$

Answer: A

Solution:

Solution:

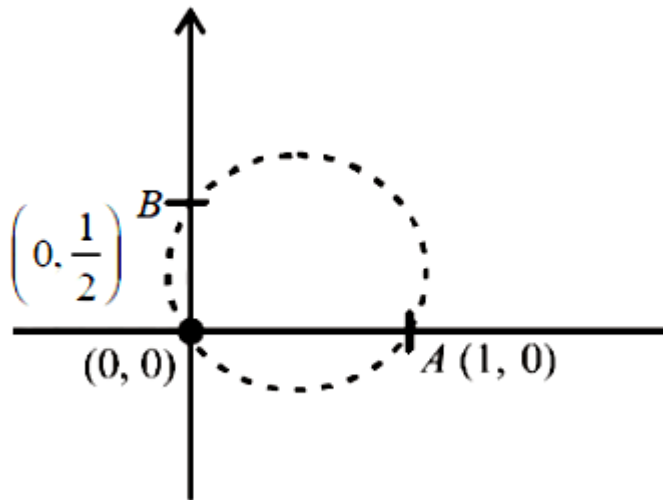

Let equation of circle be $x^2 + y^2 + 2gx + 2fy = 0$

As length of intercept on x axis is $1 = 2\sqrt{g^2 - c}$

$$\Rightarrow |g| = \frac{1}{2}$$

length of intercept on y -axis = $\frac{1}{2} = 2\sqrt{f^2 - c}$

$$\Rightarrow |f| = \frac{1}{4}$$

Equation of circle that passes through given points is

$$x^2 + y^2 - x - \frac{y}{2} = 0$$

Tangent at (0,0) is,

$$(y - 0) = \left(\frac{dy}{dx} \right)_{(0,0)} \cdot (x - 0)$$

$$\Rightarrow 2x + y = 0$$

Perpendicular distance from B(1, 0) on the tangent to the circle = $\frac{1}{\sqrt{5}}$

Perpendicular distance from $B\left(0, \frac{1}{2}\right)$ on the tangent to the circle $= \frac{2}{\sqrt{5}}$

Sum of perpendicular distance $= \frac{\frac{1}{2} + 2}{\sqrt{5}} = \frac{\sqrt{5}}{2}$.

Question321

The equation of a tangent to the parabola, $x^2 = 8y$, which makes an angle θ with the positive direction of x -axis, is
[Jan. 12, 2019 (II)]

Options:

A. $y = x \tan \theta + 2 \cot \theta$

B. $y = x \tan \theta - 2 \cot \theta$

C. $x = y \cot \theta + 2 \tan \theta$

D. $x = y \cot \theta - 2 \tan \theta$

Answer: C

Solution:

Solution:

$$x^2 = 8y$$

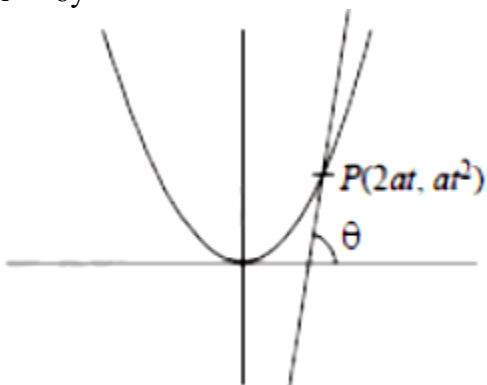

Then, equation of tangent at P

$$tx = y + at^2$$

$$\Rightarrow y = tx - at^2$$

Then, slope $t = \tan \theta$ Now, $y = \tan \theta x - 2 \tan^2 \theta$

$$\Rightarrow \cot \theta y = x - 2 \tan \theta$$
$$x = y \cot \theta + 2 \tan \theta$$

Question322

Equation of a common tangent to the parabola $y^2 = 4x$ and the hyperbola $xy = 2$ is :
[Jan. 11, 2019 (I)]

Options:

- A. $x + y + 1 = 0$
- B. $x - 2y + 4 = 0$
- C. $x + 2y + 4 = 0$
- D. $4x + 2y + 1 = 0$

Answer: C

Solution:

Solution:

Equation of a tangent to parabola $y^2 = 4x$ is:

$$y = mx + \frac{1}{m}$$

This line is a tangent to $xy = 2$

$$\therefore x \left(mx + \frac{1}{m} \right) = 2 \Rightarrow mx^2 + \frac{1}{m}x - 2 = 0$$

\therefore Tangent is common for parabola and hyperbola.

$$\therefore D = \left(\frac{1}{m} \right)^2 - 4 \cdot m \cdot (-2) = 0$$

$$\frac{1}{m^2} + 8m = 0 \quad 1 + 8m^3 = 0$$

$$m^3 = -\frac{1}{8} \Rightarrow m = -\frac{1}{2}$$

$$\therefore \text{Equation of common tangent: } y = -\frac{1}{2}x - 2$$

$$\Rightarrow 2y = -x - 4 \Rightarrow x + 2y + 4 = 0$$

Question323

If the area of the triangle whose one vertex is at the vertex of the parabola, $y^2 + 4(x - a^2) = 0$ and the other two vertices are the points of intersection of the parabola and y-axis, is 250 sq. units, then a value of 'a' is:

[Jan. 11, 2019 (II)]

Options:

- A. $5\sqrt{5}$
- B. $5(2^{1/3})$
- C. $(10)^{2/3}$
- D. 5

Answer: D

Solution:

Solution:

$$y^2 = -4(x - a^2)$$

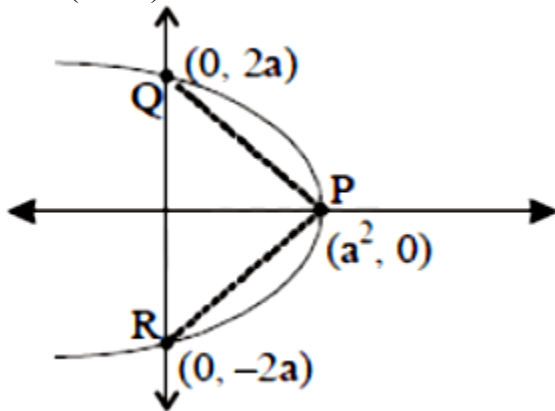

$$\text{Area} = \frac{1}{2}(4a)(a^2) = 2a^3$$

$$\text{Since } 2a^3 = 250 \Rightarrow a = 5$$

Question324

If the parabolas $y^2 = 4b(x - c)$ and $y^2 = 8ax$ have a common normal, then which one of the following is a valid choice for the ordered triad (a, b, c)?

[Jan 10, 2019 (I)]

Options:

A. $\left(\frac{1}{2}, 2, 3\right)$

B. (1,1,3)

C. $\left(\frac{1}{2}, 2, 0\right)$

D. (1,1,0)

Answer: 0

Solution:

Solution:

Normal to $y^2 = 8ax$ is (i)

$$y = mx - 4am - 2am^3$$

and normal to $y^2 = 4b(x - c)$ with slope m is

$$y = m(x - c) - 2bm - bm^3 \dots(ii)$$

Since, both parabolas have a common normal.

$$\therefore 4am + 2am^3 = cm + 2bm + bm^3$$

$$\Rightarrow 4a + 2am^2 = c + 2b + bm^2 \text{ or } m = 0$$

$$\Rightarrow (4a - c - 2b) = (b - 2a)m^2 \text{ or } (X \text{-axis is common normal always})$$

Since, x -axis is a common normal.

Hence all the options are correct for $m = 0$.

Question325

The length of the chord of the parabola $x^2 = 4y$ having equation $x - \sqrt{2}y + 4\sqrt{2} = 0$ is:

[Jan. 10, 2019 (II)]

Options:

A. $3\sqrt{2}$

B. $2\sqrt{11}$

C. $8\sqrt{2}$

D. $6\sqrt{3}$

Answer: D

Solution:

Solution:

Let intersection points be $P(x_1, y_1)$ and $Q(x_2, y_2)$

The given equations

$$x^2 = 4y \dots (i)$$

$$x - \sqrt{2}y + 4\sqrt{2} = 0 \dots (ii)$$

Use eqn (i) in eqn (ii)

$$x - \sqrt{2} \frac{x^2}{4} + 4\sqrt{2} = 0$$

$$\sqrt{2}x^2 - 4x - 16\sqrt{2} = 0$$

$$x_1 + x_2 = 2\sqrt{2}, x_1x_2 = -16, (x_1 - x_2)^2 = 8 + 64 = 72$$

Since, points P and Q both satisfy the equations (ii), then

$$x_1 - \sqrt{2}y_1 + 4\sqrt{2} = 0$$

$$x_1 - \sqrt{2}y_2 + 4\sqrt{2} = 0$$

$$(x_2 - x_1) = \sqrt{2}(y_2 - y_1) \Rightarrow (x_2 - x_1)^2 = 2(y_2 - y_1)^2$$

$$\Rightarrow PQ = \sqrt{(x_2 - x_1)^2 + (y_2 - y_1)^2}$$

$$= \sqrt{(x_2 - x_1)^2 + \frac{(x_2 - x_1)^2}{2}}$$

$$= |x_2 - x_1| \cdot \frac{\sqrt{3}}{\sqrt{2}} = 6\sqrt{2} \times \frac{\sqrt{3}}{\sqrt{2}} = 6\sqrt{3}$$

Hence, length of chord = $6\sqrt{3}$.

Question326

Axis of a parabola lies along x -axis. If its vertex and focus are at distance 2 and 4 respectively from the origin, on the positive x -axis then which of the following points does not lie on it?

[Jan 09, 2019 (I)]

Options:

A. $(5, 2\sqrt{6})$

B. $(8,6)$

C. $(6, 4\sqrt{2})$

D. $(4,-4)$

Answer: B

Solution:

Solution:

Since, vertex and focus of given parabola is $(2, 0)$ and $(4, 0)$ respectively

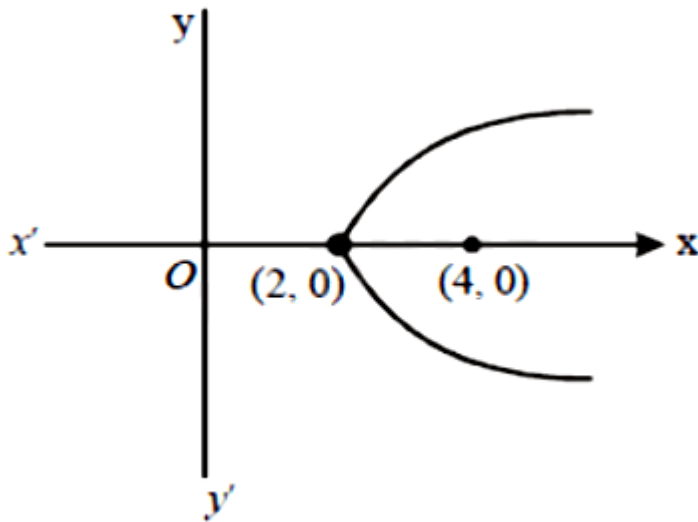

Then, equation of parabola is $(y - 0)^2 = 4 \times 2(x - 2)$

$$\Rightarrow y^2 = 8x - 16$$

Hence, the point $(8,6)$ does not lie on given parabola.

Question327

Equation of a common tangent to the circle, $x^2 + y^2 - 6x = 0$ and the parabola, $y^2 = 4x$, is :

[Jan 09, 2019 (I)]

Options:

A. $2\sqrt{3}y = 12x + 1$

B. $\sqrt{3}y = x + 3$

C. $2\sqrt{3}y = -x - 12$

D. $\sqrt{3}y = 3x + 1$

Answer: B

Solution:

Solution:

Since, the equation of tangent to parabola $y^2 = 4x$ is $y = mx + \frac{1}{m}$ (i)

The line (i) is also the tangent to circle

$$x^2 + y^2 - 6x = 0$$

Then centre of circle = (3, 0)

radius of circle = 3

The perpendicular distance from centre to tangent is equal to the radius of circle

$$\therefore \frac{\left|3m + \frac{1}{m}\right|}{\sqrt{1+m^2}} = 3 \Rightarrow \left(3m + \frac{1}{m}\right)^2 = 9(1+m^2)$$

$$\Rightarrow m = \pm \frac{1}{\sqrt{3}}$$

Then, from equation (i): $y = \pm \frac{1}{\sqrt{3}}x \pm \sqrt{3}$

Hence, $\sqrt{3}y = x + 3$ is one of the required common tangent.

Question328

Let A(4, -4) and B(9, 6) be points on the parabola, $y^2 = 4x$. Let C be chosen on the arc AOB of the parabola, where O is the origin, such that the area of $\triangle ACB$ is maximum. Then, the area (in sq. units) of $\triangle ACB$, is:

[Jan. 09, 2019 (II)]

Options:

A. $31 \frac{1}{4}$

B. $30 \frac{1}{2}$

C. 32

D. $31 \frac{3}{4}$

Answer: A

Solution:

Solution:

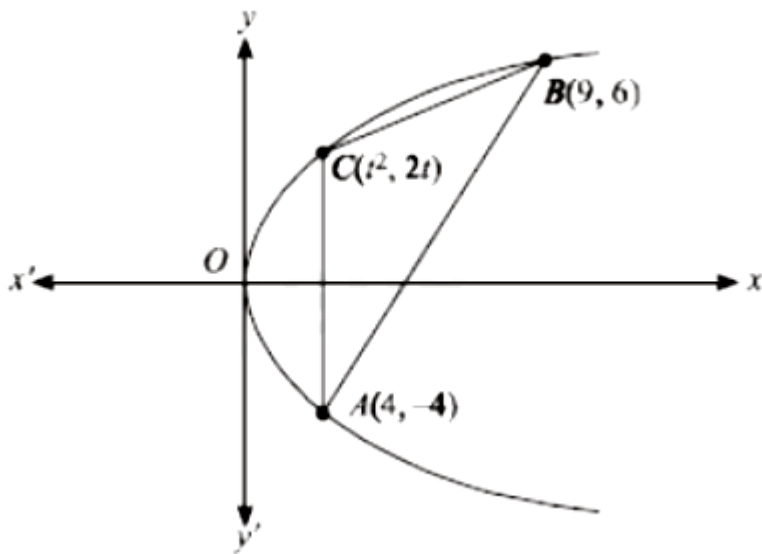

Let the coordinates of C is $(t^2, 2t)$. Since, area of $\triangle ACB$

$$= \frac{1}{2} |t^2(6+4) - 2t(9-4) + 1(-36-24)|$$

$$= \frac{1}{2} |10t^2 - 10t - 60| = 5 |t^2 - t - 6|$$

$$= 5 \left| \left(t - \frac{1}{2}\right)^2 - \frac{25}{4} \right| \quad [\text{Here, } t \in (0, 3)]$$

For maximum area, $t = \frac{1}{2}$

Hence, maximum area = $\frac{125}{4} = 31 \frac{1}{4}$ sq. units

Question329

Let S and S' be the foci of an ellipse and B be any one of the extremities of its minor axis. If $\triangle S'BS$ is a right angled triangle with

right angle at B and area $(\Delta S'BS) = 8$ sq. units, then the length of a latus rectum of the ellipse is :

[Jan. 12, 2019 (II)]

Options:

A. 4

B. $2\sqrt{2}$

C. $4\sqrt{2}$

D. 2

Answer: A

Solution:

Solution:

$\because \Delta S'BS$ is right angled triangle, then
(Slope of BS) \times (Slope of BS') = -1

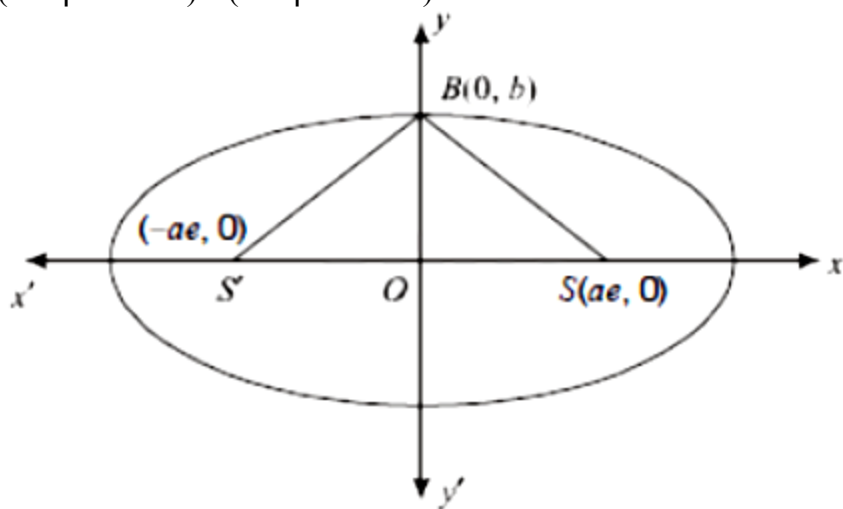

$$\frac{b}{-ae} \times \frac{b}{ae} = -1 \Rightarrow b^2 = a^2 e^2 \dots (i)$$

Since, area of $\Delta S'BS = 8$

$$\Rightarrow \frac{1}{2} \cdot 2ae \cdot b = 8 \Rightarrow b^2 = 8 \dots (ii)$$

From eqⁿ(i) $a^2 e^2 = 8$

$$\text{Also, } e^2 = 1 - \frac{b^2}{a^2}$$

$$\Rightarrow a^2 e^2 = a^2 - b^2 \Rightarrow 8 = a^2 - 8 \Rightarrow a^2 = 16$$



$$\begin{aligned} \text{Hence, required length of latus rectum} &= \frac{2b^2}{a} = \frac{2(8)}{4} \\ &= 4 \text{ units} \end{aligned}$$

Question330

If tangents are drawn to the ellipse $x^2 + 2y^2 = 2$ at all points on the ellipse other than its four vertices then the mid points of the tangents intercepted between the coordinate axes lie on the curve :

[Jan. 11, 2019 (I)]

Options:

A. $\frac{1}{4x^2} + \frac{1}{2y^2} = 1$

B. $\frac{x^2}{4} + \frac{y^2}{2} = 1$

C. $\frac{1}{2x^2} + \frac{1}{4y^2} = 1$

D. $\frac{x^2}{2} + \frac{y^2}{4} = 1$

Answer: C

Solution:

Solution:

Given the equation of ellipse,

$$\frac{x^2}{(\sqrt{2})^2} + y^2 = 1$$

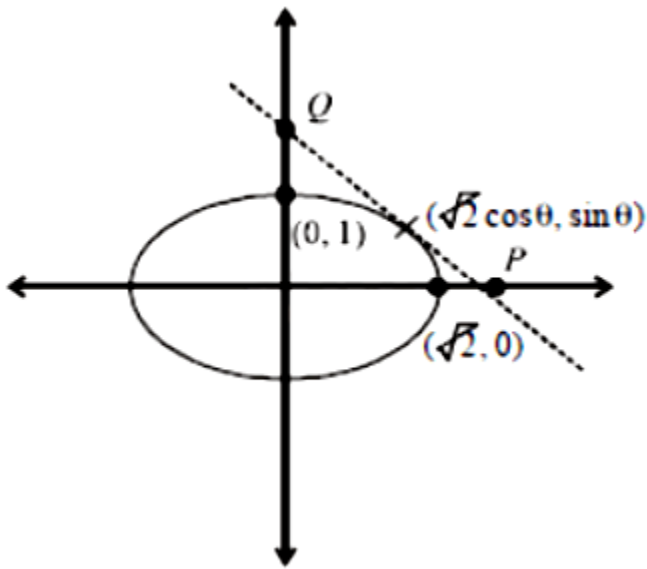

$$\frac{\sqrt{2} \cos \theta x}{2} + y \sin \theta = 1$$

$$P\left(\frac{\sqrt{2}}{\cos \theta}, 0\right) \text{ and } Q\left(0, \frac{1}{\sin \theta}\right)$$

Let mid point be (h, k)

$$\Rightarrow h = \frac{1}{\sqrt{2} \cos \theta}, k = \frac{1}{2 \sin \theta}$$

$$\text{As } \cos^2 \theta + \sin^2 \theta = 1$$

$$\therefore \frac{1}{2h^2} + \frac{1}{4k^2} = 1$$

$$\text{Locus is } \frac{1}{2x^2} + \frac{1}{4y^2} = 1$$

Question331

If the vertices of a hyperbola be at $(-2,0)$ and $(2,0)$ and one of its foci be at $(-3, 0)$, then which one of the following points does not lie on this hyperbola?

[Jan. 12, 2019 (I)]

Options:

A. $(-6, 2\sqrt{10})$

B. $(2\sqrt{6}, 5)$

C. $(4, \sqrt{15})$

D. $(6, 5\sqrt{2})$

Answer: D

Solution:

Solution:

Let the points are,

$A(2, 0)$, $A'(-2, 0)$ and $S(-3, 0)$

\Rightarrow Centre of hyperbola is $O(0, 0)$

$AA' = 2a \Rightarrow 4 = 2a \Rightarrow a = 2$

\therefore Distance between the centre and foci is ae .

$\therefore OS = ae \Rightarrow 3 = 2e \Rightarrow e = \frac{3}{2}$

$\Rightarrow b^2 = a^2(e^2 - 1) = a^2e^2 - a^2 = 9 - 4 = 5$

\Rightarrow Equation of hyperbola is

$$\frac{x^2}{4} - \frac{y^2}{5} = 1 \dots (i)$$

$\therefore (6, 5\sqrt{2})$ does not satisfy eq (i).

$\angle(6, 5\sqrt{2})$ does not lie on this hyperbola.

Question332

If a hyperbola has length of its conjugate axis equal to 5 and the distance between its foci is 13, then the eccentricity of the hyperbola is

:

[Jan. 11, 2019 (II)]

Options:

A. $\frac{13}{12}$

B. 2

C. $\frac{13}{6}$

D. $\frac{13}{8}$

Answer: A

Solution:

Solution:

$$\therefore \text{Conjugate axis} = 5$$

$$\therefore 2b = 5$$

$$\text{Distance between foci} = 13$$

$$2ae = 13$$

$$\text{Then, } b^2 = a^2(e^2 - 1)$$

$$\Rightarrow a^2 = 36$$

$$\therefore a = 6$$

$$ae = \frac{13}{2} \Rightarrow e = \frac{13}{12}$$

Question333

Let the length of the latus rectum of an ellipse with its major axis along x -axis and centre at the origin, be 8 . If the distance between the foci of this ellipse is equal to the length of its minor axis, then which one of the following points lies on it?

[Jan. 11, 2019 (II)]

Options:

A. $(4\sqrt{2}, 2\sqrt{2})$

B. $(4\sqrt{3}, 2\sqrt{2})$

C. $(4\sqrt{3}, 2\sqrt{3})$

D. $(4\sqrt{2}, 2\sqrt{3})$

Answer: B

Solution:

Solution:

$$\text{Let the ellipse be } \frac{x^2}{a^2} + \frac{y^2}{b^2} = 1$$

$$\text{Then, } \frac{2b^2}{a} = 8, 2ae = b^2 \text{ and } b^2 = a^2(1 - e^2)$$

$$\Rightarrow a = 8, b^2 = 32$$

Then, the equation of the ellipse

$$\frac{x^2}{64} + \frac{y^2}{32} = 1$$

Hence, the point $(4\sqrt{3}, 2\sqrt{2})$ lies on the ellipse.

Question334

The equation of a tangent to the hyperbola $4x^2 - 5y^2 = 20$ parallel to the line $x - y = 2$ is:

[Jan 10, 2019 (I)]

Options:

A. $x - y + 1 = 0$

B. $x - y + 7 = 0$

C. $x - y + 9 = 0$

D. $x - y - 3 = 0$

Answer: A

Solution:

Solution:

Given, the equation of line,

$$x - y = 2 \Rightarrow y = x - 2$$

\therefore its slope = $m = 1$

Equation of hyperbola is:

$$\frac{x^2}{5} - \frac{y^2}{4} = 1 \Rightarrow a^2 = 5, b^2 = 4$$

The equation of tangent to the hyperbola is,

$$y = mx \pm \sqrt{a^2 m^2 - b^2}$$

$$= x \pm \sqrt{5 - 4} \Rightarrow y = x \pm 1$$

Question335

$$\text{Let } S = \left\{ (x, y) \in \mathbb{R}^2 : \frac{y^2}{1+r} - \frac{x^2}{1-r} = 1 \right\}$$

where $r \neq \pm 1$ Then S represents:

[Jan. 10, 2019 (II)]

Options:

A. a hyperbola whose eccentricity is $\frac{2}{\sqrt{1-r}}$, when $0 < r < 1$

B. an ellipse whose eccentricity is $\sqrt{\frac{2}{r+1}}$, when $r > 1$

C. a hyperbola whose eccentricity is $\frac{2}{\sqrt{r+1}}$, when $0 < r < 1$

D. an ellipse whose eccentricity is $\frac{1}{\sqrt{r+1}}$, when $r > 1$

Answer: B

Solution:

Solution:

Since, $r \neq \pm 1$, then there are two cases, when $r > 1$

$$\frac{x^2}{r-1} + \frac{y^2}{r+1} = 1 \text{ (Ellipse)}$$

Then,

$$(r-1) = (r+1)(1-e^2) \Rightarrow 1-e^2 = \frac{(r-1)}{(r+1)}$$

$$\Rightarrow e^2 = 1 - \frac{(r-1)}{(r+1)} = \frac{2}{(r+1)}$$

$$\Rightarrow e = \sqrt{\frac{2}{(r+1)}}$$

When $0 < r < 1$,

then

$$\frac{x^2}{1-r} - \frac{y^2}{1+r} = -1 \text{ (Hyperbola)}$$

$$\text{Then, } (1-r) = (1+r)(e^2-1) \Rightarrow e^2 = 1 + \frac{(r-1)}{(r+1)} = \frac{2r}{(r+1)}$$

$$\Rightarrow e = \sqrt{\frac{2r}{r+1}}$$

Question336

Let $0 < \theta < \frac{\pi}{2}$. If the eccentricity of the hyperbola $\frac{x^2}{\cos^2\theta} - \frac{y^2}{\sin^2\theta} = 1$ is greater than 2, then the length of its latus rectum lies in the interval:
[Jan 09, 2019 (I)]

Options:

- A. $(3, \infty)$
- B. $(3/2, 2]$
- C. $(2,3]$
- D. $(1, 3/2]$

Answer: A

Solution:

Solution:

$$\because a^2 = \cos^2\theta, b^2 = \sin^2\theta$$

$$\text{and } e > 2 \Rightarrow e^2 > 4 \Rightarrow 1 + b^2/a^2 > 4$$

$$\Rightarrow 1 + \tan^2\theta > 4$$

$$\Rightarrow \sec^2\theta > 4 \Rightarrow \theta \in \left(\frac{\pi}{3}, \frac{\pi}{2} \right)$$

Latus rectum.

$$LR = \frac{2b^2}{a} = \frac{2\sin^2\theta}{\cos\theta} = 2(\sec\theta - \cos\theta)$$

$$\Rightarrow \frac{d(LR)}{d\theta} = 2(\sec\theta \tan\theta + \sin\theta) > 0 \quad \forall \theta \in \left(\frac{\pi}{3}, \frac{\pi}{2} \right)$$

$$\therefore \min(LR) = 2 \left(\sec \frac{\pi}{3} - \cos \frac{\pi}{3} \right) = 2 \left(2 - \frac{1}{2} \right) = 3$$

$$\max(LR) \text{ tends to infinity as } \theta \rightarrow \frac{\pi}{2}$$

Hence, length of latus rectum lies in the interval $(3, \infty)$

Question337

A hyperbola has its centre at the origin, passes through the point (4,2) and has transverse axis of length 4 along the x-axis. Then the eccentricity of the hyperbola is:
[Jan. 09, 2019 (II)]

Options:

A. $\frac{3}{2}$

B. $\sqrt{3}$

C. 2

D. $\frac{2}{\sqrt{3}}$

Answer: D

Solution:

Solution:

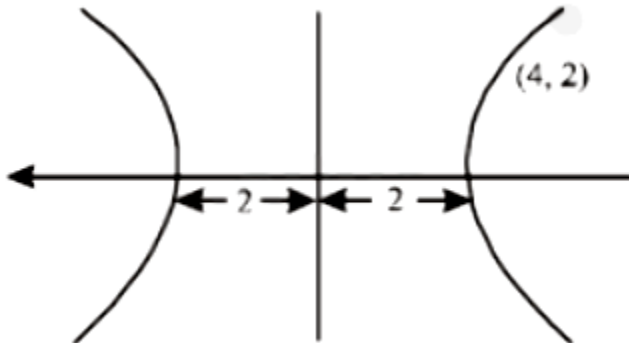

Consider equation of hyperbola

$$\frac{x^2}{a^2} - \frac{y^2}{b^2} = 1$$

$\therefore (4, 2)$ lies on hyperbola

$$\therefore \frac{16}{4} - \frac{4}{b^2} = 1$$

$$\therefore b^2 = \frac{4}{3}$$

$$\text{Since, eccentricity} = \sqrt{1 + \frac{b^2}{a^2}}$$

$$\text{Hence, eccentricity} = \sqrt{1 + \frac{3}{4}} = \sqrt{1 + \frac{1}{3}} = \frac{2}{\sqrt{3}}$$

Question338

If the angle of intersection at a point where the two circles with radii 5cm and 12cm intersect is 90° , then the length (in cm) of their common chord is :

[April 12, 2019 (I)]

Options:

- A. $\frac{13}{5}$
- B. $\frac{120}{13}$
- C. $\frac{60}{13}$
- D. $\frac{13}{2}$

Answer: B

Solution:

Solution:

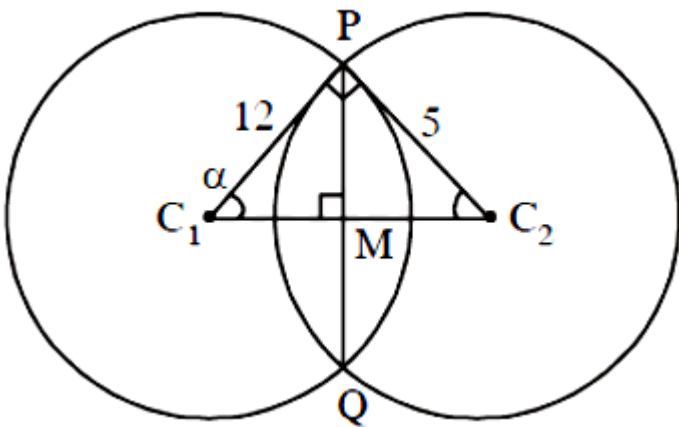

According to the diagram,

$$\text{In } \triangle PC_1C_2, \tan \alpha = \frac{5}{12} \Rightarrow \sin \alpha = \frac{5}{13}$$

$$\text{In } \triangle PC_1M, \sin \alpha = \frac{PM}{12} \Rightarrow \frac{5}{13} = \frac{PM}{12} \Rightarrow PM = \frac{60}{13}$$

$$\text{Hence, length of common chord (PQ)} = \frac{120}{13}$$

Question339

A circle touching the x -axis at (3,0) and making an intercept of length 8 on the y -axis passes through the point :

[April 12, 2019 (II)]

Options:

A. (3,10)

B. (3,5)

C. (2,3)

D. (1,5)

Answer: A

Solution:

Solution:

Let centre of circle is C and circle cuts the y -axis at B and A. Let mid-point of chord BA is M .

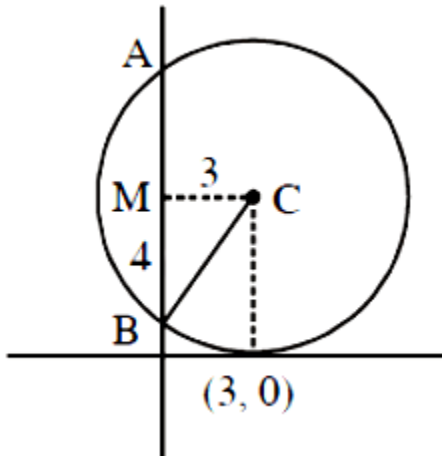

$$CB = \sqrt{MC^2 + MB^2}$$

$$\sqrt{3^2 + 4^2} = 5 = \text{radius of circle}$$

\therefore equation of circle is $(x - 3)^2 + (y - 5)^2 = 5^2$ (3,10) satisfies this equation.

Although there will be another circle satisfying the same conditions that will lie below the x -axis having equation $(x - 3)^2 + (y - 5)^2 = 5^2$

Question340

If the circles $x^2 + y^2 + 5Kx + 2y + K = 0$ and $2(x^2 + y^2) + 2Kx + 3y - 1 = 0$, ($K \in \mathbb{R}$), intersect at the points P and Q then the line $4x + 5y - K = 0$ passes through P and Q, for:
 [April 10, 2019 (I)]

Options:

- A. infinitely many values of K
- B. no value of K .
- C. exactly two values of K
- D. exactly one value of K

Answer: B

Solution:

Solution:

$$S_1 \equiv x^2 + y^2 + 5Kx + 2y + K = 0$$

$$S_2 \equiv x^2 + y^2 + Kx + \frac{3}{2}y - \frac{1}{2} = 0$$

Equation of common chord is $S_1 - S_2 = 0$

$$\Rightarrow 4Kx + \frac{y}{2} + K + \frac{1}{2} = 0 \dots (i)$$

Equation of the line passing through the intersection points P & Q is,

$$4x + 5y - K = 0 \dots (ii)$$

Comparing (i) and (ii),

$$\frac{4K}{4} = \frac{1}{10} = \frac{2K + 1}{-2K} \dots (iii)$$

$$\Rightarrow K = \frac{1}{10} \text{ and } -2K = 20K + 10$$

$$\Rightarrow 22K = -10 \Rightarrow K = \frac{-5}{11}$$

$$\therefore K = \frac{1}{10} \text{ or } \frac{-5}{11} \text{ is not satisfying equation (3)}$$

\therefore No value of K exists.

Question341

The line $x = y$ touches a circle at the point $(1,1)$. If the circle also passes through the point $(1, -3)$, then its radius is:
 [April 10, 2019 (I)]

Options:

- A. 3
- B. $2\sqrt{2}$
- C. 2
- D. $3\sqrt{2}$

Answer: B

Solution:

Solution:

Equation of circle which touches the line $y = x$ at $(1,1)$ is $(x-1)^2 + (y-1)^2 + \lambda(y-x) = 0$
 This circle passes through $(1,-3)$

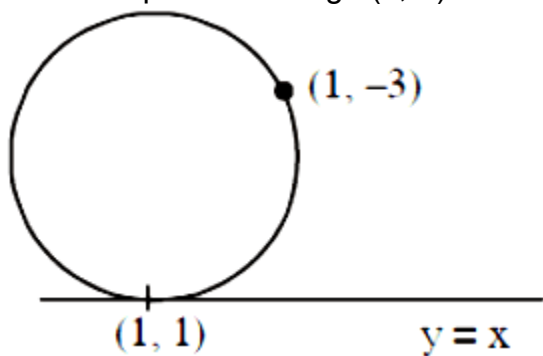

$$\begin{aligned} \therefore 0 + 16 + \lambda(-3 - 1) &= 0 \\ \Rightarrow 16 + \lambda(-4) &= 0 \Rightarrow \lambda = 4 \\ \text{Hence, equation of circle will be.} \\ (x-1)^2 + (y-1)^2 + 4y - 4x &= 0 \\ \Rightarrow x^2 + y^2 - 6x + 2y + 2 &= 0 \\ \therefore \text{Radius} &= \sqrt{9 + 1 - 2} = 2\sqrt{2} \end{aligned}$$

Question342

The locus of the centres of the circles, which touch the circle, $x^2 + y^2 = 1$ externally, also touch the y -axis and lie in the first

quadrant, is:
[April 10, 2019 (II)]

Options:

A. $x = \sqrt{1 + 4y}, y \geq 0$

B. $y = \sqrt{1 + 2x}, x \geq 0$

C. $y = \sqrt{1 + 4x}, x \geq 0$

D. $x = \sqrt{1 + 2y}, y \geq 0$

Answer: B

Solution:

Solution:

Let centre of required circle is (h, k) .

$OO' = r + r'$ [By the diagram]

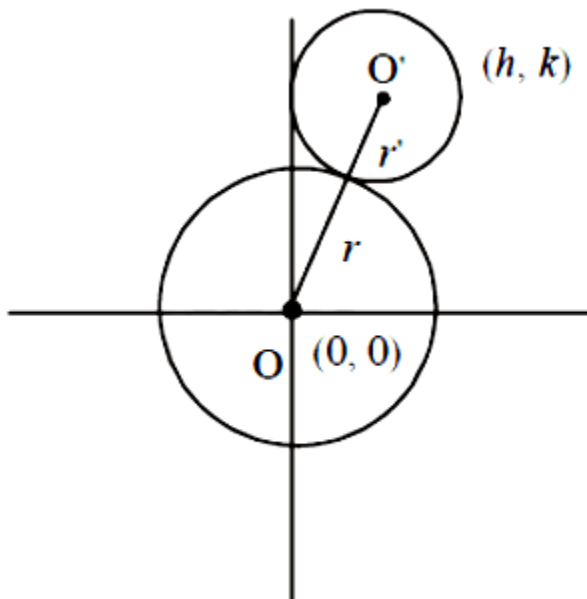

$$\Rightarrow \sqrt{h^2 + k^2} = 1 + h$$

$$\Rightarrow h^2 + k^2 = 1 + h^2 + 2h$$

$$\Rightarrow k^2 = 1 + 2h$$

$$\therefore \text{locus is } y = \sqrt{1 + 2x}, x \geq 0$$

Question343

All the points in the set $S = \left\{ \frac{\alpha+i}{\alpha-1} : \alpha \in \mathbf{R} \right\}$ ($i = \sqrt{-1}$) lie on a:

[April 09, 2019 (I)]

Options:

A. straight line whose slope is 1 .

B. circle whose radius is 1 .

C. circle whose radius is $\sqrt{2}$.

D. straight line whose slope is -1 .

Answer: B

Solution:

Solution:

$$\text{Let } z \in S \text{ then } z = \frac{\alpha+i}{\alpha-i}$$

Since, z is a complex number and let $z = x + iy$

$$\text{Then, } x + iy = \frac{(\alpha+i)^2}{\alpha^2+1} \text{ (by rationalisation)}$$

$$\Rightarrow x + iy = \frac{(\alpha^2-1)}{\alpha^2+1} + \frac{i(2\alpha)}{\alpha^2+1}$$

Then compare both sides

$$x = \frac{\alpha^2-1}{\alpha^2+1} \dots \text{(i)}$$

$$y = \frac{2\alpha}{\alpha^2+1} \dots \text{(ii)}$$

Now squaring and adding equations (i) and (ii)

$$\Rightarrow x^2 + y^2 = \frac{(\alpha^2-1)^2}{(\alpha^2+1)^2} + \frac{4\alpha^2}{(\alpha^2+1)^2} = 1$$

Question344

If a tangent to the circle $x^2 + y^2 = 1$ intersects the coordinate axes at distinct points P and Q, then the locus of the midpoint of PQ is:

[April 09, 2019 (I)]

Options:

A. $x^2 + y^2 - 4x^2y^2 = 0$

B. $x^2 + y^2 - 2xy = 0$

C. $x^2 + y^2 - 16x^2y^2 = 0$

D. $x^2 + y^2 - 2x^2y^2 = 0$

Answer: A

Solution:

Solution:

Let any tangent to circle $x^2 + y^2 = 1$ is $x \cos \theta + y \sin \theta = 1$

Since, P and Q are the point of intersection on the co- ordinate axes.

Then $P \equiv \left(\frac{1}{\cos \theta}, 0 \right)$ & $Q \equiv \left(0, \frac{1}{\sin \theta} \right)$

mid-point of PQ be $M \equiv \left(\frac{1}{2 \cos \theta}, \frac{1}{2 \sin \theta} \right) \equiv (h, k)$

$\Rightarrow \cos \theta = \frac{1}{2h} \dots (i)$

$\sin \theta = \frac{1}{2k} \dots (ii)$

Now squaring and adding equation (i) and (ii)

$$\frac{1}{h^2} + \frac{1}{k^2} = 4$$

\therefore locus of M is $x^2 + y^2 = 4x^2y^2$

$\Rightarrow h^2 + k^2 = 4h^2k^2$

Question345

**The common tangent to the circles $x^2 + y^2 = 4$ and $x^2 + y^2 + 6x + 8y - 24 = 0$ also passes through the point:
[April 09, 2019 (II)]**

Options:

A. (4,-2)

B. (-6,4)

C. (6,-2)

D. (-4,6)

Answer: C

Solution:

Solution:

By the diagram, $d_{c_1c_2} = |r_1 - r_2|$

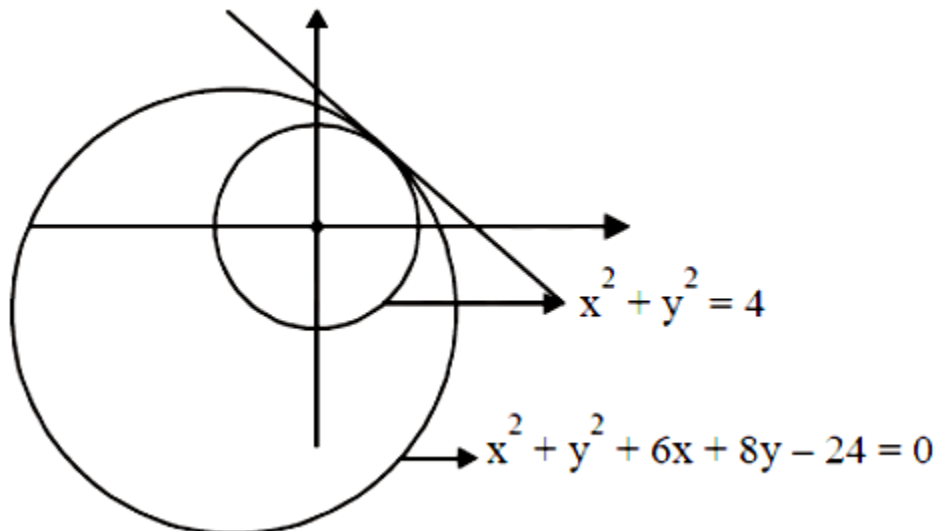

Equation of common tangent is,

$$S_1 - S_2 = 0$$

$$6x + 8y - 20 = 0 \Rightarrow 3x + 4y - 10 = 0$$

Hence (6,-2) lies on it.

Question346

The sum of the squares of the lengths of the chords intercepted on the circle, $x^2 + y^2 = 16$, by the lines, $x + y = n$ $n \in \mathbb{N}$, where \mathbb{N} is the set of all natural numbers, is
[April 08, 2019 (I)]

Options:

A. 320

B. 105

C. 160

D. 210

Answer: D

Solution:

Solution:

Let the chord $x + y = n$ cuts the circle $x^2 + y^2 = 16$ at P and Q Length of perpendicular from O on PQ

$$= \left| \frac{0+0-n}{\sqrt{1^2+1^2}} \right| = \frac{n}{\sqrt{2}}$$

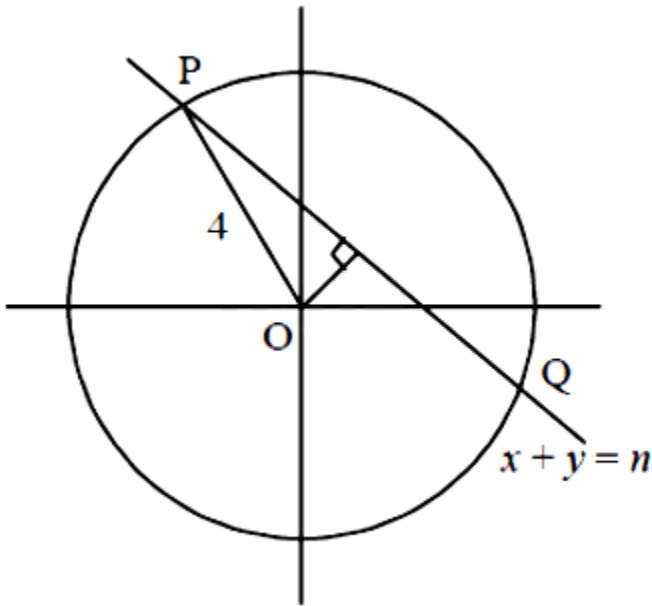

Then, length of chord PQ = $2 \sqrt{4^2 - \left(\frac{n}{\sqrt{2}}\right)^2} = 2 \sqrt{16 - \frac{n^2}{2}}$

Thus only possible values of n are 1,2,3,4,5 .

Hence, the sum of squares of lengths of chords

$$= \sum_{n=1}^5 4 \left(16 - \frac{n^2}{2} \right) = 64 \times 5 - 2 \cdot \frac{5 \times 6 \times 11}{6} = 210$$

Question347

If $y = mx + 4$ is a tangent to both the parabolas, $y^2 = 4x$ and $x^2 = 2by$, then b is equal to:

[April 12, 2019 (II)]

Options:

- A. -32
- B. -64
- C. -128
- D. 128

Answer: C

Solution:

Solution:

$y = mx + 4 \dots\dots(i)$
 Tangent of $y^2 = 4x$ is
 $\Rightarrow y = mx + \frac{1}{m} \dots\dots(ii)$

[\because Equation of tangent of $y^2 = 4ax$ is $y = mx + \frac{a}{m}$] From (i) and (ii)

$4 = \frac{1}{m} \Rightarrow m = \frac{1}{4}$

So, line $y = \frac{1}{4}x + 4$ is also tangent to parabola

$x^2 = 2by$, so solve both equations.

$x^2 = 2b \left(\frac{x+16}{4} \right)$

$\Rightarrow 2x^2 - bx - 16b = 0$

$\Rightarrow D = 0$

[For tangent] $\Rightarrow b^2 - 4 \times 2 \times (-16b) = 0$

$\Rightarrow b^2 + 32 \times 4b = 0$

$b = -128, b = 0$ (not possible)

Question348

**The tangents to the curve $y = (x - 2)^2 - 1$ at its points of intersection with the line $x - y = 3$, intersect at the point :
 [April 10, 2019 (II)]**

Options:

A. $\left(\frac{5}{2}, 1 \right)$

B. $\left(-\frac{5}{2}, -1\right)$

C. $\left(\frac{5}{2}, -1\right)$

D. $\left(-\frac{5}{2}, 1\right)$

Answer: C

Solution:

Solution:

Tangent to the curve $y = (x - 2)^2 - 1$ at any point (h, k) is. $\Rightarrow \frac{1}{2}(y + k) = (x - 2)(h - 2) - 1$

$$\Rightarrow \frac{y+k}{2} = xh - 2x - 2h + 3$$

$$\Rightarrow (2h - 4)x - y - 4h + 6 - k = 0$$

Given line, $x - y - 3 = 0$

$$\Rightarrow \frac{2h - 4}{1} = \frac{4h - 6 + k}{3} = 1$$

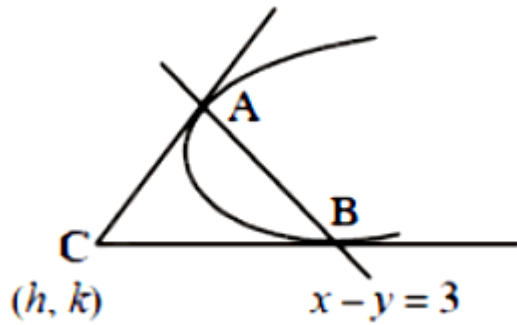

$$\Rightarrow h = \frac{5}{2}, k = -1$$

Question349

If the line $ax + y = c$, touches both the curves $x^2 + y^2 = 1$ and $y^2 = 4\sqrt{2}x$, then $|c|$ is equal to
[April 09, 2019 (II)]

Options:

A. 2

B. $\frac{1}{\sqrt{2}}$

C. $\frac{1}{2}$

D. $\sqrt{2}$

Answer: D

Solution:

Solution:

Equation of tangent on $y^2 = 4\sqrt{2}x$ is $yt = x + \sqrt{2}t^2$ This is also tangent on circle

$$\therefore \left| \frac{\sqrt{2}t^2}{\sqrt{1+t^2}} \right| = 1 \Rightarrow 2t^4 = 1 + t^2 \Rightarrow t^2 = 1$$

Hence, equation is $\pm y = x + \sqrt{2} \Rightarrow |c| = \sqrt{2}$

Question350

**The area (in sq. units) of the smaller of the two circles that touch the parabola, $y^2 = 4x$ at the point (1,2) and the x-axis is:
[April 09, 2019 (I)]**

Options:

A. $8\pi(2 - \sqrt{2})$

B. $4\pi(2 - \sqrt{2})$

C. $4\pi(3 + \sqrt{2})$

D. $8\pi(3 - 2\sqrt{2})$

Answer: D

Solution:

Solution:

The circle and parabola will have common tangent at P (1, 2).

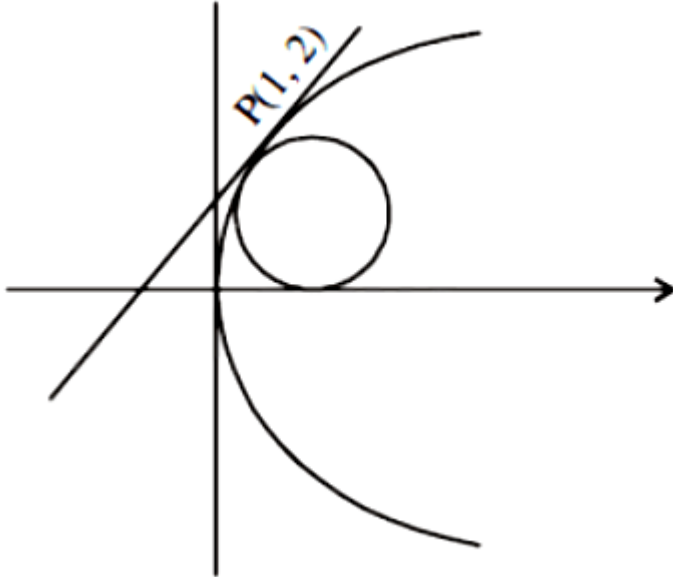

So, equation of tangent to parabola is,

$$y \times (2) = \frac{4(x+1)}{2} \Rightarrow 2y = 2x + 2 \Rightarrow y = x + 1$$

Let equation of circle (by family of circles) is $(x - x_1)^2 + (y - y_1)^2 + \lambda T = 0$

$$\Rightarrow c \equiv (x - 1)^2 + (y - 2)^2 + \lambda(x - y + 1) = 0$$

\therefore circles touches x-axis.

\therefore y-coordinate of centre = radius

$$\Rightarrow c \equiv x^2 + y^2 + (\lambda - 2)x + (-\lambda - 4)y + (\lambda + 5) = 0$$

$$\frac{\lambda + 4}{2} = \sqrt{\left(\frac{\lambda - 2}{2}\right)^2 + \left(\frac{-\lambda - 4}{2}\right)^2} - (\lambda + 5)$$

$$\Rightarrow \frac{\lambda^2 - 4\lambda + 4}{4} = \lambda + 5 \Rightarrow \lambda^2 - 4\lambda + 4 = 4\lambda + 20$$

$$\Rightarrow \lambda^2 - 8\lambda - 16 = 0 \Rightarrow \lambda = 4 \pm 4\sqrt{2}$$

$$\Rightarrow \lambda = 4 - 4\sqrt{2} (\because \lambda = 4 + 4\sqrt{2} \text{ forms bigger circle})$$

Hence, centre of circle $(2\sqrt{2} - 2, 4 - 2\sqrt{2})$ and radius = $4 - 2\sqrt{2}$

$$\therefore \text{area} = \pi(4 - 2\sqrt{2})^2 = 8\pi(3 - 2\sqrt{2})$$

Question351

If one end of a focal chord of the parabola, $y^2 = 16x$ is at (1, 4), then the length of this focal chord is:

[April 09, 2019 (I)]

Options:

A. 25

B. 22

C. 24

D. 20

Answer: A

Solution:

Solution:

$$\because y^2 = 16x$$

$\Rightarrow a = 4$ One end of focal chord of the parabola is at (1,4)

y- coordinate of focal chord is 2 at

$$\therefore 2at = 4$$

$$\Rightarrow t = \frac{1}{2}$$

Hence, the required length of focal chord

$$= a \left(t + \frac{1}{t} \right)^2 = 4 \times \left(2 + \frac{1}{2} \right)^2 = 25$$

Question352

The shortest distance between the line $y = x$ and the curve $y^2 = x - 2$ is

:

[April 08, 2019 (I)]

Options:

A. 2

B. $\frac{7}{8}$

C. $\frac{7}{4\sqrt{2}}$

D. $\frac{11}{4\sqrt{2}}$

Answer: C

Solution:

Solution:

The shortest distance between line $y = x$ and parabola = the distance LM between line $y = x$ and tangent of parabola having slope 1 .

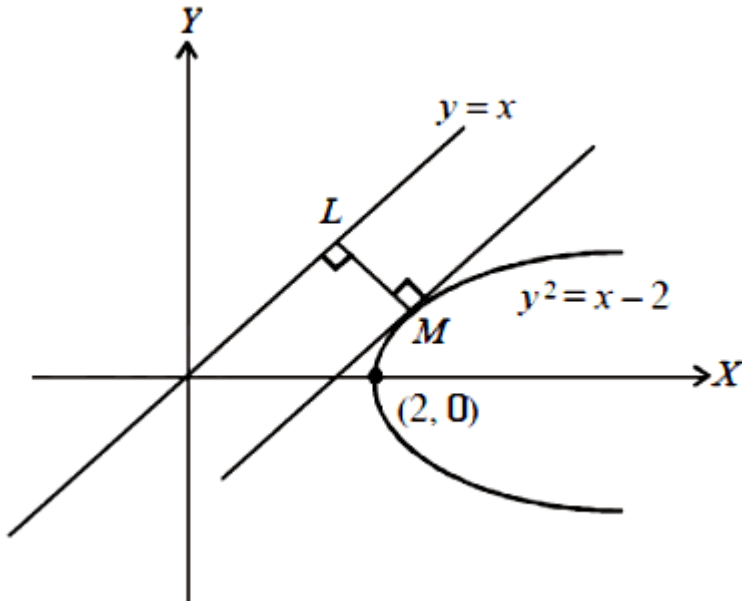

Let equation of tangent of parabola having slope 1 is,

$$y = m(x - 2) + \frac{a}{m}$$

Here $m = 1$ and $a = \frac{1}{4}$

\therefore equation of tangent is: $y = x - \frac{7}{4}$

Distance between the line $y - x = 0$ and $y - x + \frac{7}{4} = 0$

$$= \left| \frac{\frac{7}{4} - 0}{\sqrt{1^2 + 1^2}} \right| = \frac{7}{4\sqrt{2}}$$

Question353

If the tangents on the ellipse $4x^2 + y^2 = 8$ at the points $(1, 2)$ and (a, b) are perpendicular to each other, then a^2 is equal to :
[April 08, 2019 (I)]

Options:

A. $\frac{128}{17}$

B. $\frac{64}{17}$

C. $\frac{4}{17}$

D. $\frac{2}{17}$

Answer: D

Solution:

Solution:

Since (a, b) touches the given ellipse $4x^2 + y^2 = 8$

$\therefore 4a^2 + b^2 = 8$ Equation of tangent on the ellipse at the point A(1, 2) is:

$$4x + 2y = 8 \Rightarrow 2x + y = 4 \Rightarrow y = -2x + 4$$

But, also equation of tangent at P(a, b) is:

$$4ax + by = 8 \Rightarrow y = -\frac{4a}{b}x + \frac{8}{b}$$
 Since, tangents are perpendicular to each other.

$$\Rightarrow \frac{-4a}{b} = \frac{-1}{2} \Rightarrow b = 8a$$

from (1) & (2)

$$\text{we get: } \Rightarrow a = \pm \frac{2}{\sqrt{34}} \Rightarrow a^2 = \frac{2}{17}$$

Question354

The tangent to the parabola $y^2 = 4x$ at the point where it intersects the circle $x^2 + y^2 = 5$ in the first quadrant, passes through the point:
[April 08, 2019 (II)]

Options:

A. $\left(-\frac{1}{3}, \frac{4}{3}\right)$

B. $\left(\frac{1}{4}, \frac{3}{4}\right)$

C. $\left(\frac{3}{4}, \frac{7}{4}\right)$

D. $\left(-\frac{1}{4}, \frac{1}{2}\right)$

Answer: C

Solution:

Solution:

To find intersection point of $x^2 + y^2 = 5$ and $y^2 = 4x$, substitute $y^2 = 4x$ in $x^2 + y^2 = 5$, we get

$$x^2 + 4x - 5 = 0 \Rightarrow x^2 + 5x - x - 5 = 0$$

$$\Rightarrow x(x + 5) - 1(x + 5) = 0$$

$$\therefore x = 1, -5$$

Intersection point in 1st quadrant be (1,2) .

Now, equation of tangent to $y^2 = 4x$ at (1,2) is

$$y \times 2 = 2(x + 1) \Rightarrow y = x + 1$$

$$\Rightarrow x - y + 1 = 0 \dots \dots (i)$$

Hence, $\left(\frac{3}{4}, \frac{7}{4}\right)$ lies on (i)

Question355

If the normal to the ellipse $3x^2 + 4y^2 = 12$ at a point P on it is parallel to the line, $2x + y = 4$ and the tangent to the ellipse at P passes through Q (4,4) then PQ is equal to :

[April 12, 2019 (I)]

Options:

A. $\frac{5\sqrt{5}}{2}$

B. $\frac{\sqrt{61}}{2}$

C. $\frac{\sqrt{221}}{2}$

D. $\frac{\sqrt{157}}{2}$

Answer: A

Solution:

Slope of tangent on the line $2x + y = 4$ at point P is $\frac{1}{2}$ Given ellipse is,

$$3x^2 + 4y^2 = 12 \Rightarrow \frac{x^2}{2^2} + \frac{y^2}{(\sqrt{3})^2} = 1$$

Let point $P(2 \cos \theta, \sqrt{3} \sin \theta)$

\therefore equation of tangent on the ellipse, at P is,

$$\frac{x}{2} \cos \theta + \frac{y}{\sqrt{3}} \sin \theta = 1$$

$$\Rightarrow m_T = -\frac{\sqrt{3}}{2} \cot \theta$$

\therefore both the tangents are parallel $\Rightarrow -\frac{\sqrt{3}}{2} \cot \theta = \frac{1}{2}$

$$\Rightarrow \tan \theta = -\sqrt{3} \Rightarrow \theta = \pi - \frac{\pi}{3} \text{ or } \theta = 2\pi - \frac{\pi}{3}$$

Case-1: $\theta = \frac{2\pi}{3}$, then point $P\left(-1, \frac{3}{2}\right)$ and $PQ = \frac{5\sqrt{5}}{2}$

Case-2: $\theta = \frac{5\pi}{3}$, then tangent does not pass through $Q(4, 4)$

Question356

An ellipse, with foci at $(0,2)$ and $(0,-2)$ and minor axis of length 4 , passes through which of the following points?

[April 12, 2019 (II)]

Options:

A. $(\sqrt{2}, 2)$

B. $(2, \sqrt{2})$

C. $(2, 2\sqrt{2})$

D. $(1, 2\sqrt{2})$

Answer: A

Solution:

Let the equation of ellipse: $\frac{x^2}{a^2} + \frac{y^2}{b^2} = 1$

Given that length of minor axis is 4 i.e. $a = 4$

Also given $be = 2$

$$\therefore a^2 = b^2(1 - e^2) \Rightarrow 4 = b^2 - 4 \Rightarrow b = 2\sqrt{2}$$

Hence, equation of ellipse will be $\frac{x^2}{4} + \frac{y^2}{8} = 1$

$\therefore (\sqrt{2}, 2)$ satisfies this equation.

\therefore ellipse passes through $(\sqrt{2}, 2)$

Question 357

If the line $x - 2y = 12$ is tangent to the ellipse $\frac{x^2}{a^2} + \frac{y^2}{b^2} = 1$ at the point

$\left(3, -\frac{9}{2}\right)$, then the length of the latus rectum of the ellipse is :

[April 10, 2019 (I)]

Options:

A. 9

B. $12\sqrt{2}$

C. 5

D. $8\sqrt{3}$

Answer: A

Solution:

Solution:

Equation of tangent to $\frac{x^2}{a^2} + \frac{y^2}{b^2} = 1$ at $\left(3, -\frac{\beta}{2}\right)$ is,

$$\frac{3x}{a^2} - \frac{9y}{2b^2} = 1$$

But given equation of tangent is, $x - 2y = 12$

$$\therefore \frac{3}{a^2} = \frac{-9}{2b^2 \cdot (-2)} = \frac{1}{12} \quad (\text{On comparing})$$

$$\Rightarrow a^2 = 3 \times 12 \text{ and } b^2 = \frac{9 \times 12}{4}$$

$$\Rightarrow a = 6 \text{ and } b = 3\sqrt{3}$$

$$\text{Therefore, latus rectum} = \frac{2b^2}{a} = \frac{2 \times 27}{6} = 9$$

Question358

The tangent and normal to the ellipse $3x^2 + 5y^2 = 32$ at the point $P(2, 2)$ meet the x -axis at Q and R , respectively. Then the area (in sq. units) of the triangle PQR is:

[April 10, 2019 (II)]

Options:

A. $\frac{34}{15}$

B. $\frac{14}{3}$

C. $\frac{16}{3}$

D. $\frac{68}{15}$

Answer: D

Solution:

Solution:

$$3x^2 + 5y^2 = 32 \Rightarrow \frac{3x^2}{32} + \frac{5y^2}{32} = 1$$

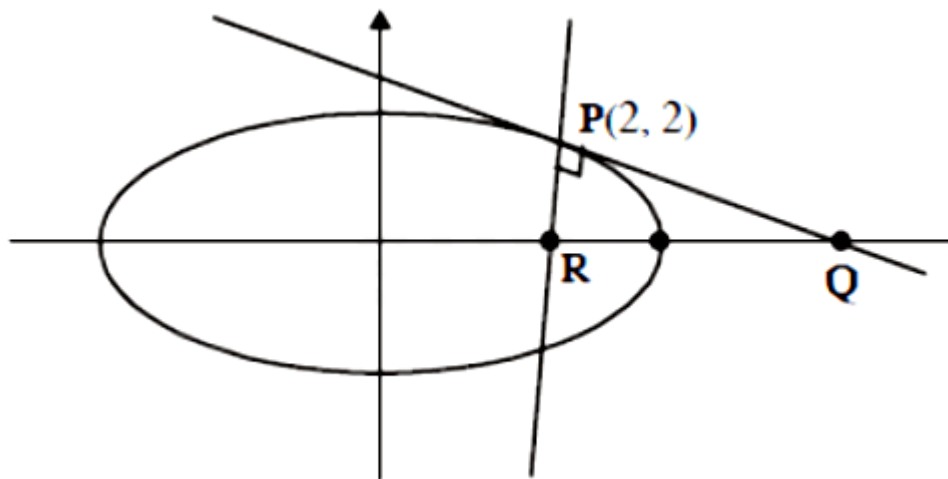

Tangent on the ellipse at P is

$$\frac{3(2)x}{32} + \frac{5(2)y}{32} = 1 \Rightarrow \frac{3x}{16} + \frac{5y}{16} = 1$$

\therefore co-ordinates of Q will be $\left(\frac{16}{3}, 0\right)$

Now, normal at P is $\frac{32}{3(2)} - \frac{32y}{5(2)} = \frac{32}{3} - \frac{32}{5}$

\therefore co-ordinates of R will be $\left(\frac{4}{5}, 0\right)$

Hence, area of $\Delta PQR = \frac{1}{2}(PQ)(PR)$

$$= \frac{1}{2} \sqrt{\frac{136}{9}} \cdot \sqrt{\frac{136}{25}} = \frac{68}{15}$$

Question359

If the tangent to the parabola $y^2 = x$ at a point (α, β) , ($\beta > 0$) is also a tangent to the ellipse, $x^2 + 2y^2 = 1$, then α is equal to:

[April 09, 2019 (II)]

Options:

A. $\sqrt{2} - 1$

B. $2\sqrt{2} - 1$

C. $2\sqrt{2} + 1$

D. $\sqrt{2} + 1$

Answer: D

Solution:

Solution:

Let tangent to parabola at point $\left(\frac{1}{4m^2}, -\frac{1}{2m}\right)$ is $y = mx + \frac{1}{4m}$ and tangent to ellipse is,

$$y = mx \pm \sqrt{m^2 + \frac{1}{2}}$$

Now, condition for common tangency,

$$\frac{1}{4m} = \pm \sqrt{m^2 + \frac{1}{2}} \Rightarrow \frac{1}{16m^2} = m^2 + \frac{1}{2}$$

$$\Rightarrow 16m^4 + 8m^2 - 1 = 0 \Rightarrow m^2 = \frac{-8 \pm \sqrt{64 + 64}}{2(16)}$$

$$= \frac{-8 \pm 8\sqrt{2}}{2(16)} = \frac{\sqrt{2} - 1}{4}$$

$$\alpha = \frac{1}{4m^2} = \frac{1}{4 \frac{\sqrt{2} - 1}{4}} = \sqrt{2} + 1$$

Question360

In an ellipse, with centre at the origin, if the difference of the lengths of major axis and minor axis is 10 and one of the foci is at $(0, 5\sqrt{3})$, then the length of its latus rectum is:

[April 08, 2019 (II)]

Options:

A. 10

B. 5

C. 8

D. 6

Answer: B

Solution:

Given that focus is $(0, 5\sqrt{3}) \Rightarrow |b| > |a|$

Let $b > a > 0$ and foci is $(0, \pm be)$

$$\therefore a^2 = b^2 - b^2 e^2 \Rightarrow b^2 e^2 = b^2 - a^2$$

$$be = \sqrt{b^2 - a^2} \Rightarrow b^2 - a^2 = 75 \dots (i)$$

$$\therefore 2b - 2a = 10 \Rightarrow b - a = 5 \dots (ii)$$

From (i) and (ii)

$$b + a = 15 \dots (iii)$$

On solving (ii) and (iii), we get

$$\Rightarrow b = 10, a = 5$$

$$\text{Now, length of latus rectum} = \frac{2a^2}{b} = \frac{50}{10} = 5$$

Question361

Let P be the point of intersection of the common tangents to the parabola $y^2 = 12x$ and hyperbola $8x^2 - y^2 = 8$. If S and S' denote the foci of the hyperbola where S lies on the positive x-axis then P divides SS' in a ratio :

[April 12, 2019 (I)]

Options:

A. 13: 11

B. 14: 13

C. 5: 4

D. 2: 1

Answer: C

Solution:

Solution:

$$\text{Equation of tangent to } y^2 = 12x \text{ is } y = mx + \frac{3}{m}$$

Equation of tangent to

$$\frac{x^2}{1} - \frac{y^2}{8} = 1 \text{ is } y = mx \pm \sqrt{m^2 - 8}$$

\therefore parabola and hyperbola have common tangent.

$$\therefore \frac{3}{m} = \pm \sqrt{m^2 - 8} \Rightarrow \frac{9}{m^2} = m^2 - 8$$

Put $m^2 = u$

$$u^2 - 8u - 9 = 0 \Rightarrow u^2 - 9u + u - 9 = 0$$

$$\Rightarrow (u + 1)(u - 9) = 0$$

$$\therefore u = m^2 \geq 0 \Rightarrow u = m^2 = 9 \Rightarrow m = \pm 3$$

\therefore equation of tangent is $y = 3x + 1$ or $y = -3x - 1$

\therefore intersection point is $P\left(-\frac{1}{3}, 0\right)$.

$$e = \sqrt{1 + \frac{b^2}{a^2}} \Rightarrow e = \sqrt{1 + \frac{8}{1}} \Rightarrow e = 3$$

\therefore foci $(\pm 3, 0)$

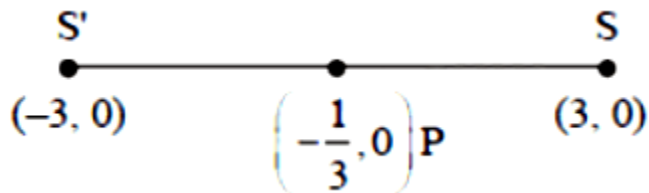

$$\frac{SP}{SP'} = \frac{3 + \frac{1}{3}}{3 - \frac{1}{3}} = \frac{\frac{10}{3}}{\frac{8}{3}} = \frac{5}{4}$$

Question362

The equation of a common tangent to the curves, $y^2 = 16x$ and $xy = -4$, is :

[April 12, 2019 (II)]

Options:

A. $x - y + 4 = 0$

B. $x + y + 4 = 0$

C. $x - 2y + 16 = 0$

D. $2x - y + 2 = 0$

Answer: A

Solution:

Solution:

Given curves, $y^2 = 16x$ and $xy = -4$

Equation of tangent to the given parabola; $y = mx + \frac{4}{m}$

∴ This is common tangent.

So, put $y = mx + \frac{4}{m}$ in $xy = -4$.

$$x\left(mx + \frac{4}{m}\right) + 4 = 0 \Rightarrow mx^2 + \frac{4}{m}x + 4 = 0$$

$$D = 0 \Rightarrow \frac{16}{m^2} = 16m \Rightarrow m^3 = 1 \Rightarrow m = 1$$

equation of common tangent is $y = x + 4$

Question363

If a directrix of a hyperbola centred at the origin and passing through the point $(4, -2\sqrt{3})$ is $5x = 4\sqrt{5}$ and its eccentricity is e , then :
[April 10, 2019 (I)]

Options:

A. $4e^4 - 24e^2 + 27 = 0$

B. $4e^4 - 12e^2 - 27 = 0$

C. $4e^4 - 24e^2 + 35 = 0$

D. $4e^4 + 8e^2 - 35 = 0$

Answer: C

Solution:**Solution:**

∴ directrix of a hyperbola is:

$$5x = 4\sqrt{5} \Rightarrow x = \frac{4}{\sqrt{5}} \Rightarrow \frac{a}{e} = \frac{4}{\sqrt{5}}$$

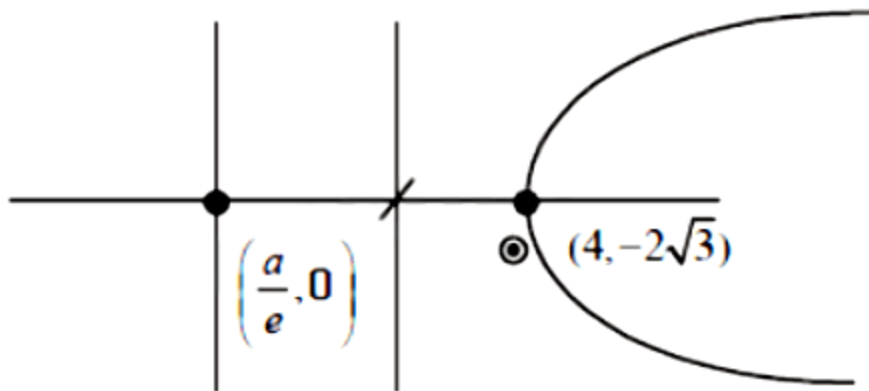

Now, hyperbola $\frac{x^2}{a^2} - \frac{y^2}{b^2} = 1$ passes through $(4, -2\sqrt{3})$

$$\therefore \frac{16}{a^2} - \frac{12}{a^2 e^2 - a^2} = 1$$

$$\left[\because e^2 = 1 + \frac{b^2}{a^2} \Rightarrow a^2 e^2 - a^2 = b^2 \right]$$

$$\Rightarrow \frac{4}{a^2} \left[\frac{4}{1} - \frac{3}{e^2 - 1} \right] = 1 \Rightarrow 4e^2 - 4 - 3 = (e^2 - 1) \left(\frac{a^2}{4} \right)$$

$$\Rightarrow 4(4e^2 - 7) = (e^2 - 1) \left(\frac{4e}{\sqrt{5}} \right)^2$$

$$\Rightarrow 4e^4 - 24e^2 + 35 = 0$$

Question 364

If $5x + 9 = 0$ is the directrix of the hyperbola $16x^2 - 9y^2 = 144$, then its corresponding focus is :

[April 10, 2019 (II)]

Options:

A. (5,0)

B. $\left(-\frac{5}{3}, 0\right)$

C. $\left(\frac{5}{3}, 0\right)$

D. (-5,0)

Answer: D

Solution:

Solution:

$$16x^2 - 9y^2 = 144 \Rightarrow \frac{x^2}{9} - \frac{y^2}{16} = 1$$

Then focus is $S'(-ae, 0)$

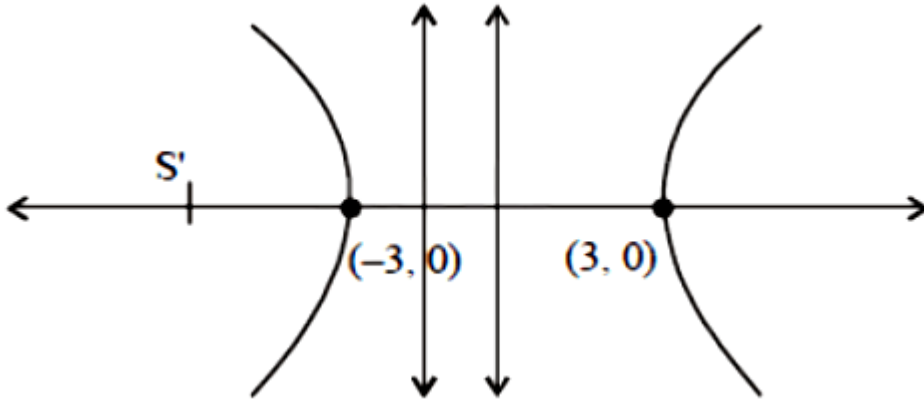

$$x = \frac{-9}{5}$$

$$a = 3, b = 4 \Rightarrow e^2 = 1 + \frac{16}{9} = \frac{25}{9} \left[\because e = \sqrt{1 + \frac{b^2}{a^2}} \right]$$

$$\therefore \text{the focus } S' \equiv \left(3 - \times \frac{5}{3}, 0 \right) \equiv (-5, 0)$$

Question365

If the line $y = mx + 7\sqrt{3}$ is normal to the hyperbola $\frac{x^2}{24} - \frac{y^2}{18} = 1$, then a value of m is:

[April 09, 2019 (I)]

Options:

A. $\frac{\sqrt{5}}{2}$

B. $\frac{\sqrt{15}}{2}$

C. $\frac{2}{\sqrt{5}}$

D. $\frac{3}{\sqrt{5}}$

Answer: C

Solution:

Solution:

Since, $1x + my + n = 0$ is a normal to $\frac{x^2}{a^2} - \frac{y^2}{b^2} = 1$,

$$\text{then } \frac{a^2}{l^2} - \frac{b^2}{m^2} = \frac{(a^2 + b^2)^2}{n^2}$$

but it is given that $mx - y + 7\sqrt{3}$ is normal to hyperbola

$$\frac{x^2}{24} - \frac{y^2}{18} = 1$$

$$\text{then } \frac{24}{m^2} - \frac{18}{(-1)^2} = \frac{(24 + 18)^2}{(7\sqrt{3})^2} \Rightarrow m = \frac{2}{\sqrt{5}}$$

Question 366

If the eccentricity of the standard hyperbola passing through the point (4,6) is 2, then the equation of the tangent to the hyperbola at (4,6) is : [April. 08, 2019 (II)]

Options:

A. $x - 2y + 8 = 0$

B. $2x - 3y + 10 = 0$

C. $2x - y - 2 = 0$

D. $3x - 2y = 0$

Answer: C

Solution:

Solution:

Let equation of hyperbola be

$$\frac{x^2}{a^2} - \frac{y^2}{b^2} = 1 \dots (i)$$

$$\therefore e = \sqrt{1 + \frac{b^2}{a^2}} \Rightarrow b^2 = a^2(e^2 - 1)$$

$$e = 2 \Rightarrow b^2 = 3a^2 \dots (ii)$$

Equation (i) passes through (4,6) ,

$$\frac{16}{a^2} - \frac{36}{b^2} = 1 \dots (iii)$$

On solving (i) and (ii), we get

$$a^2 = 4, b^2 = 12$$

Now equation of hyperbola is $\frac{x^2}{4} - \frac{y^2}{12} = 1$

Now equation of tangent to the hyperbola at (4,6) is

$$\frac{4x}{4} - \frac{6y}{12} = 1 \Rightarrow x - \frac{y}{2} = 1 \Rightarrow 2x - y = 2$$

Question367

If a circle C, whose radius is 3, touches externally the circle, $x^2 + y^2 + 2x - 4y - 4 = 0$ at the point (2, 2), then the length of the intercept cut by this circle c, on the x -axis is equal to [Online April 16, 2018]

Options:

A. $\sqrt{5}$

B. $2\sqrt{3}$

C. $3\sqrt{2}$

D. $2\sqrt{5}$

Answer: D

Solution:

Solution:

Given circle is:

$$x^2 + y^2 + 2x - 4y - 4 = 0$$

\therefore its centre is (-1,2) and radius is 3 units.

Let A = (x, y) be the centre of the circle C

$$\therefore \frac{x-1}{2} = 2 \Rightarrow x = 5 \text{ and } \frac{y+2}{2} = 2 \Rightarrow y = 2$$

So the centre of C is (5,2) and its radius is 3

\therefore equation of centre C is:

$$x^2 + y^2 - 10x - 4y + 20 = 0$$

∴ The length of the intercept it cuts on the x -axis

$$= 2\sqrt{g^2 - c} = 2\sqrt{25 - 20} = 2\sqrt{5}$$

Question368

A circle passes through the points (2,3) and (4,5) . If its centre lies on the line, $y - 4x + 3 = 0$, then its radius is equal to [Online April 15, 2018]

Options:

A. $\sqrt{5}$

B. 1

C. $\sqrt{2}$

D. 2

Answer: C

Solution:

Solution:

Equation of the line passing through the points (2,3) and (4,5) is

$$y - 3 = \left(\frac{5-3}{4-2} \right) x - 2 \Rightarrow x - y + 1 = 0 \dots (i)$$

Equation of the perpendicular line passing through the midpoint (3,4) is $x + y - 7 = 0 \dots (ii)$

∴ (ii) Lines (1) and (2) intersect at the center of the circle. So, the center of the circle is (3,4)

Therefore, the radius is

$$\sqrt{(x_2 - x_1)^2 + (y_2 - y_1)^2} = \sqrt{(2-3)^2 + (3-4)^2} = \sqrt{2} \text{ units.}$$

Question369

Two parabolas with a common vertex and with axes along x -axis and y-axis, respectively, intersect each other in the first quadrant. if the length of the latus rectum of each parabola is 3, then the equation of

the common tangent to the two parabolas is? [Online April 15, 2018]

Options:

A. $3(x + y) + 4 = 0$

B. $8(2x + y) + 3 = 0$

C. $4(x + y) + 3 = 0$

D. $x + 2y + 3 = 0$

Answer: C

Solution:

Solution:

As origin is the only common point to x -axis and y-axis, so, origin is the common vertex

Let the equation of two of parabolas be $y^2 = 4ax$ and $x^2 = 4by$

Now latus rectum of both parabolas = 3 $\therefore 4a = 4b = 3 \Rightarrow a = b = \frac{3}{4}$

\therefore Two parabolas are $y^2 = 3x$ and $x^2 = 3y$

Suppose $y = mx + c$ is the common tangent.

$$\therefore y^2 = 3x \Rightarrow (mx + c)^2 = 3x \Rightarrow m^2x^2 + (2mc - 3)x + c^2 = 0$$

As, the tangent touches at one point only

$$\text{So, } b^2 - 4ac = 0$$

$$\Rightarrow (2mc - 3)^2 - 4m^2c^2 = 0$$

$$\Rightarrow 4m^2c^2 + 9 - 12mc - 4m^2c^2 = 0$$

$$\Rightarrow c = \frac{9}{12m} = \frac{3}{4m} \dots (i)$$

$$\therefore x^2 = 3y \Rightarrow x^2 = 3(mx + c) \Rightarrow x^2 - 3mx - 3c = 0$$

$$\text{Again, } b^2 - 4ac = 0$$

$$\Rightarrow 9m^2 - 4(1)(-3c) = 0$$

$$\Rightarrow 9m^2 = -12c \dots (ii)$$

Form (i) and (ii)

$$m^2 = \frac{-4c}{3} = \frac{-4}{3} \left(\frac{3}{4m} \right)$$

$$\Rightarrow m^3 = -1 \Rightarrow m = -1 \Rightarrow c = \frac{-3}{4}$$

$$\text{Hence, } y = mx + c = -x - \frac{3}{4}$$

$$\Rightarrow 4(x + y) + 3 = 0$$



Question370

The tangent to the circle $C_1 : x^2 + y^2 - 2x - 1 = 0$ at the point (2,1) cuts off a chord of length 4 from a circle C_2 whose centre is (3,-2) . The radius of C_2 is

[Online April 15, 2018]

Options:

A. $\sqrt{6}$

B. 2

C. $\sqrt{2}$

D. 3

Answer: A

Solution:

Solution:

Here, equation of tangent on C_1 at (2,1) is: $2x + y - (x + 2) - 1 = 0$

Or $x + y = 3$

If it cuts off the chord of the circle C_2 then the equation of the chord is:

$$x + y = 3$$

∴ distance of the chord from (3,-2) is :

$$d = \left| \frac{3 - 2 - 3}{\sqrt{2}} \right| = \sqrt{2}$$

Also, length of the chord is $l = 4$

$$\therefore \text{radius of } C_2 = r = \sqrt{\left(\frac{l}{2}\right)^2 + d^2}$$

$$= \sqrt{(2)^2 + (\sqrt{2})^2} = \sqrt{6}$$

Question371

Tangents drawn from the point (-8,0) to the parabola $y^2 = 8x$ touch the parabola at P and Q. If F is the focus of the parabola, then the area of

**the triangle PF Q (in sq. units) is equal to
[Online April 15, 2018]**

Options:

A. 48

B. 32

C. 24

D. 64

Answer: A

Solution:

Solution:

Equation of the chord of contact PQ is given by:

$$T = 0 \text{ or } T \equiv yy_1 - 4(x + x_1),$$

where $(x_1, y_1) \equiv (-8, 0)$

\therefore Equation becomes: $x = 8$

& Chord of contact is $x = 8$

\therefore Coordinates of point P and Q are (8,8) and (8,-8) and focus of the parabola is F (2, 0)

\therefore Area of triangle PQF = $\frac{1}{2} \times (8 - 2) \times (8 + 8) = 48$ sq. units

Question372

**If the length of the latus rectum of an ellipse is 4 units and the distance between a focus and its nearest vertex on the major axis is $\frac{3}{2}$ units, then its eccentricity is?
[Online April 16, 2018]**

Options:

A. $\frac{1}{2}$

B. $\frac{2}{3}$

C. $\frac{1}{9}$

D. $\frac{1}{3}$

Answer: D

Solution:

Solution:

Let for ellipse coordinates of focus and vertex are $(ae, 0)$ and $(a, 0)$ respectively.

$$\therefore \text{Distance between focus and vertex} = a(1 - e) = \frac{3}{2} \text{ (given)}$$

$$\Rightarrow a - \frac{3}{2} = ae$$

$$\Rightarrow a^2 + \frac{9}{4} - 3a = a^2e^2 \dots (i)$$

$$\text{Length of latus rectum} = \frac{2b^2}{a} = 4$$

$$\Rightarrow b^2 = 2a \dots (ii)$$

$$e^2 = 1 - \frac{b^2}{a^2}$$

$$\Rightarrow e^2 = 1 - \frac{2a}{a^2} \text{ (from(ii))}$$

$$\Rightarrow e^2 = 1 - \frac{2}{a} \dots (iii)$$

Substituting the value of e^2 in eq. (i) we get;

$$\Rightarrow a^2 + \frac{9}{4} - 3a = a^2 \left(1 - \frac{2}{a}\right)$$

$$\Rightarrow a = \frac{9}{4}$$

\therefore from eq. (iii) we get;

$$e^2 = 1 - \frac{2}{a} = 1 - \frac{8}{9} = \frac{1}{9}$$

$$\Rightarrow e = \frac{1}{3}$$

Question373

The locus of the point of intersection of the lines, $\sqrt{2}x - y + 4\sqrt{2}k = 0$ and $\sqrt{2}kx + ky - 4\sqrt{2} = 0$ (k is any non-zero real parameter) is.

[Online April 16, 2018]

Options:

- A. A hyperbola with length of its transverse axis $8\sqrt{2}$
- B. An ellipse with length of its major axis $8\sqrt{2}$
- C. An ellipse whose eccentricity is $\frac{1}{\sqrt{3}}$
- D. A hyperbola whose eccentricity is $\sqrt{3}$

Answer: A

Solution:

Solution:

Here, lines are:

$$\sqrt{2}x - y + 4\sqrt{2}k = 0$$

$$\Rightarrow \sqrt{2}x + 4\sqrt{2}k = y \dots (i)$$

$$\text{and } \sqrt{2}kx + ky - 4\sqrt{2} = 0 \dots (ii)$$

Put the value of y from (i) in (ii) we get;

$$\Rightarrow 2\sqrt{2}kx + 4\sqrt{2}(k^2 - 1) = 0$$

$$\Rightarrow x = \frac{2(1 - k^2)}{k}, y = \frac{2\sqrt{2}(1 + k^2)}{k}$$

$$\therefore \left(\frac{y}{4\sqrt{2}}\right)^2 - \left(\frac{x}{4}\right)^2 = 1$$

\therefore length of transverse axis

$$2a = 2 \times 4\sqrt{2} = 8\sqrt{2}$$

Hence, the locus is a hyperbola with length of its transverse axis equal to $8\sqrt{2}$

Question374

Tangent and normal are drawn at P(16, 16) on the parabola $y^2 = 16x$, which intersect the axis of the parabola at A and B, respectively. If C is the centre of the circle through the points P, A and B and $\angle CPB = \theta$, then a value of $\tan \theta$ is:

[2018]

Options:

- A. 2

B. 3

C. $\frac{4}{3}$

D. $\frac{1}{2}$

Answer: A

Solution:

Solution:

Equation of tangent at P(16, 16) is given as:

$$x - 2y + 16 = 0$$

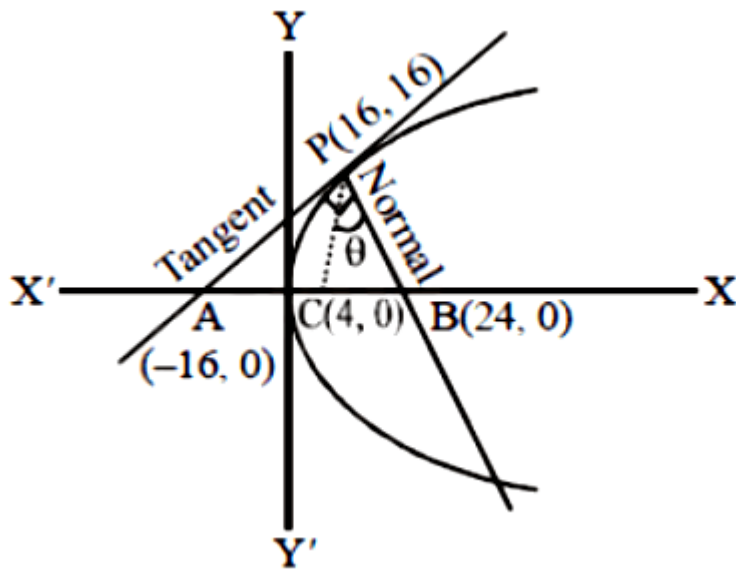

$$\text{Slope of PC}(m_1) = \frac{4}{3}$$

$$\text{Slope of PB}(m_2) = -2$$

$$\text{Hence, } \tan \theta = \left| \frac{m_1 - m_2}{1 + m_1 \cdot m_2} \right| = \left| \frac{\frac{4}{3} + 2}{1 - \frac{4}{3} \cdot 2} \right|$$

$$\Rightarrow \tan \theta = 2$$

Question375

If the tangent at (1,7) to the curve $x^2 = y - 6$ touches the circle $x^2 + y^2 + 16x + 12y + c = 0$ then the value of c is :

[2018]

Options:

A. 185

B. 85

C. 95

D. 195

Answer: C

Solution:

Solution:

Equation of tangent at $(1,7)$ to $x^2 = y - 6$ is $2x - y + 5 = 0$

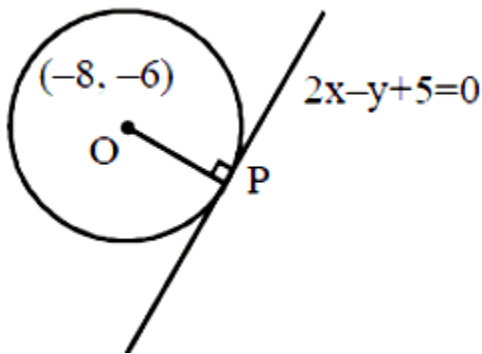

Now, perpendicular from centre
 $O(-8, -6)$ to $2x - y + 5 = 0$
should be equal to radius of the circle
 $\Rightarrow \sqrt{5} = \sqrt{100 - c} \Rightarrow c = 95$

$$\therefore \left| \frac{-16 + 6 + 5}{\sqrt{5}} \right| = \sqrt{64 + 36 - c}$$

$$\Rightarrow \sqrt{5} = \sqrt{100 - c} \Rightarrow c = 95$$

Question376

Two sets A and B are as under :

$$A = \{ (a, b) \in \mathbb{R} \times \mathbb{R} : |a - 5| < 1 \text{ and } |b - 5| < 1 \}$$

$$B = \{ (a, b) \in \mathbb{R} \times \mathbb{R} : 4(a - 6)^2 + 9(b - 5)^2 \leq 36 \} \cdot \text{Then}$$

[2018]

Options:

- A. $A \subset B$
- B. $A \cap B = \phi$ (an empty set)
- C. neither $A \subset B$ nor $B \subset A$
- D. $B \subset A$

Answer: A

Solution:

Solution:

$$A = \{(a, b) \in \mathbb{R} \times \mathbb{R} : |a - 5| < 1, |b - 5| < 1\}$$

$$\text{Let } a - 5 = x, b - 5 = y$$

Set A contains all points inside $|x| < 1, |y| < 1$

$$B = \{(a, b) \in \mathbb{R} \times \mathbb{R} : 4(a - 6)^2 + 9(b - 5)^2 \leq 36\}$$

Set B contains all points inside or on

$$\frac{(x - 1)^2}{9} + \frac{y^2}{4} = 1$$

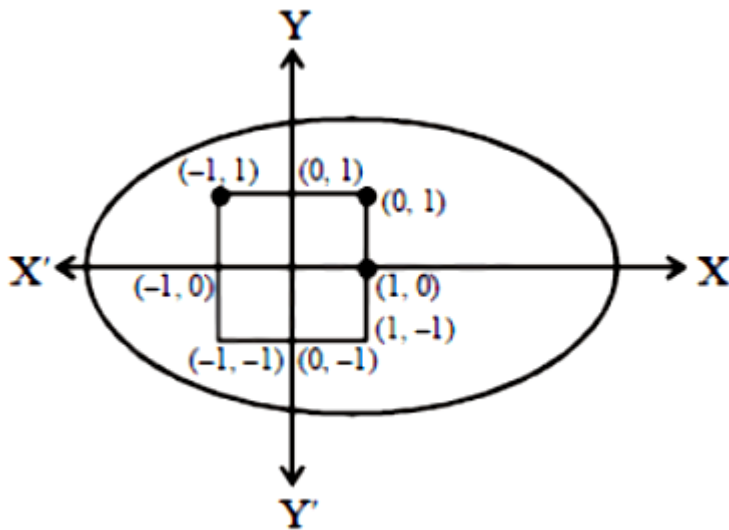

$\therefore (\pm 1, \pm 1)$ lies inside the ellipse.

Hence, $A \subset B$.

Question 377

Tangents are drawn to the hyperbola $4x^2 - y^2 = 36$ at the points P and Q. If these tangents intersect at the point T (0, 3) then the area (in sq.

units) of $\Delta PT Q$ is:
[2018]

Options:

A. $54\sqrt{3}$

B. $60\sqrt{3}$

C. $36\sqrt{5}$

D. $45\sqrt{5}$

Answer: D

Solution:

Solution:

Here equation of hyperbola is

$$\frac{x^2}{9} - \frac{y^2}{36} = 1$$

Now, PQ is the chord of contact

\therefore Equation of PQ is:

$$\frac{x(0)}{9} - \frac{y(3)}{36} = 1$$

$$\Rightarrow y = -12$$

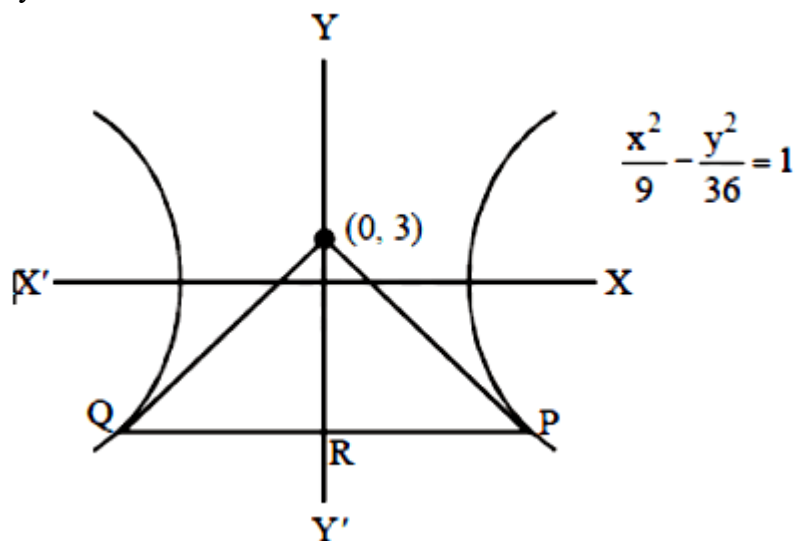

$$\Delta PQT = \frac{1}{2} \times TR \times PQ$$

$$\because P \equiv (3\sqrt{5}, -12) \quad \therefore TR = 3 + 12 = 15$$

$$\text{Area of } \Delta PQT = \frac{1}{2} \times 15 \times 6\sqrt{5} = 45\sqrt{5} \text{ sq. units}$$

Question378

The equation $\text{Im} \left(\frac{iz-2}{z-i} \right) + 1 = 0, z \in \mathbb{C}, z \neq i$ represents a part of a circle having radius equal to :
[Online April 9, 2017]

Options:

A. 2

B. 1

C. $\frac{3}{4}$

D. $\frac{1}{2}$

Answer: C

Solution:

Solution:

Let $z = x + yi$

$$\text{Im} \left[\left(\frac{ix - y - 2}{x + (y-1)i} \right) \left(\frac{x - (y-1)i}{x - (y-1)i} \right) \right] + 1 = 0$$

On solving, we get:

$$2x^2 + 2y^2 - y - 1 = 0$$

$$\Rightarrow x^2 + y^2 - 1/2y - 1/2 = 0$$

$$\Rightarrow x^2 + \left(y - \frac{1}{4} \right)^2 = \frac{9}{16}$$

$$\Rightarrow r = \frac{3}{4}$$

Question379

A line drawn through the point $P(4, 7)$ cuts the circle $x^2 + y^2 = 9$ at the points A and B. Then $PA \cdot PB$ is equal to

[Online April 9, 2017]

Options:

A. 53

B. 56

C. 74

D. 65

Answer: B

Solution:

Solution:

P(4, 7). Here, $x = 4$, $y = 7$

$x - y = -3$

$\therefore PA \times PB = PT^2$

Also; $PT = \sqrt{x^2 + y^2 - (x - y)^2}$

$\Rightarrow PT = \sqrt{16 + 49 - 9} = \sqrt{56}$

$\Rightarrow PT^2 = 56 \therefore PA \times PB = 56$

Question380

The two adjacent sides of a cyclic quadrilateral are 2 and 5 and the angle between them is 60° . If the area of the quadrilateral is $4\sqrt{3}$, then the perimeter of the quadrilateral is :

[Online April 9, 2017]

Options:

A. 12.5

B. 13.2

C. 12

D. 13

Answer: C

Solution:

Solution:

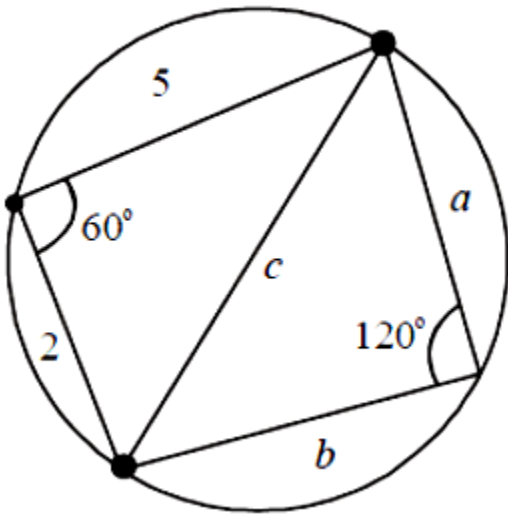

$$\text{Here; } \cos \theta = \frac{a^2 + b^2 - c^2}{2ab} \text{ and } \theta = 60^\circ$$

$$\Rightarrow \cos 60^\circ = \frac{4 + 25 - c^2}{2 \cdot 2 \cdot 5}$$

$$\Rightarrow 10 = 29 - c^2$$

$$\Rightarrow c^2 = 19$$

$$\Rightarrow c = \sqrt{19}$$

$$\text{also; } \cos \theta = \frac{a^2 + b^2 - c^2}{2ab} \text{ and } \theta = 120^\circ$$

$$\Rightarrow -\frac{1}{2} = \frac{a^2 + b^2 - 19}{2ab}$$

$$\Rightarrow a^2 + b^2 - 19 = -ab$$

$$\Rightarrow a^2 + b^2 + ab = 19$$

$$\therefore \text{Area} = \frac{1}{2} \times 2 \times 5 \sin 60^\circ + \frac{1}{2} ab \sin 120^\circ = 4\sqrt{3}$$

$$\Rightarrow \frac{5\sqrt{3}}{2} + \frac{ab\sqrt{3}}{4} = 4\sqrt{3}$$

$$\Rightarrow \frac{ab}{4} = 4 - \frac{5}{2} = \frac{3}{2}$$

$$\Rightarrow \frac{ab = 6}{a^2 + b^2 = 13}$$

$$\Rightarrow a = 2, b = 3$$

$$\text{Perimeter} = \text{Sum of all sides} = 2 + 5 + 2 + 3 = 12$$

Question381

Let $z \in \mathbb{C}$, the set of complex numbers. Then the equation,
 $2z + 3i | - | z - i | = 0$ represents :
[Online April 8, 2017]

Options:

- A. a circle with radius $\frac{8}{3}$.
- B. a circle with diameter $\frac{10}{3}$.
- C. an ellipse with length of major axis $\frac{16}{3}$.
- D. an ellipse with length of minor axis $\frac{16}{9}$.

Answer: A

Solution:

Solution:

$$\begin{aligned} \text{Let } z = x + iy \Rightarrow 2 | x + i(y + 3) | &= | x + i(y - 1) | \\ \Rightarrow 2 \sqrt{x^2 + (y + 3)^2} &= \sqrt{x^2 + (y - 1)^2} \\ \Rightarrow 4x^2 + 4(y + 3)^2 &= x^2 + (y - 1)^2 \\ \Rightarrow 3x^2 &= y^2 - 2y + 1 - 4y^2 - 24y - 36 \\ \Rightarrow 3x^2 + 3y^2 + 26y + 35 &= 0 \text{ (which is a circle)} \\ \Rightarrow x^2 + y^2 + \frac{26}{3}y + \frac{35}{3} &= 0 \\ \Rightarrow r &= \sqrt{0 + \frac{169}{9} - \frac{35}{3}} \\ \Rightarrow r &= \sqrt{\frac{64}{9}} = \frac{8}{3} \end{aligned}$$

Question382

If a point P has co-ordinates (0,-2) and Q is any point on the circle,
 $x^2 + y^2 - 5x - y + 5 = 0$, then the maximum value of $(PQ)^2$ is :
[Online April 8, 2017]

Options:

A. $\frac{25 + \sqrt{6}}{2}$

B. $14 + 5\sqrt{3}$

C. $\frac{47 + 10\sqrt{6}}{2}$

D. $8 + 5\sqrt{3}$

Answer: B

Solution:

Solution:

Given that $x^2 + y^2 - 5x - y + 5 = 0$

$$\Rightarrow (x - 5/2)^2 - \frac{25}{4} + (y - 1/2)^2 - 1/4 = 0$$

$$\Rightarrow (x - 5/2)^2 + (y - 1/2)^2 = 3/2$$

on circle $\left[Q \equiv \left(5/2 + \sqrt{3/2} \cos Q, \frac{1}{2} + \sqrt{3/2} \sin Q \right) \right] \Rightarrow PQ^2 = \left(\frac{5}{2} + \sqrt{3/2} \cos Q \right)^2 + \left(\frac{5}{2} + \sqrt{3/2} \sin Q \right)^2$

$$\Rightarrow PQ^2 = \frac{25}{2} + \frac{3}{2} + 5\sqrt{3/2}(\cos Q + \sin Q)$$

$$= 14 + 5\sqrt{3/2}(\cos Q + \sin Q)$$

\therefore Maximum value of PQ^2

$$= 14 + 5\sqrt{3/2} \times \sqrt{2} = 14 + 5\sqrt{3}$$

Question383

If two parallel chords of a circle, having diameter 4 units, lie on the opposite sides of the centre and subtend angles $\cos^{-1}\left(\frac{1}{7}\right)$ and $\sec^{-1}(7)$ at the centre respectively, then the distance between these chords, is :
[Online April 8, 2017]

Options:

A. $\frac{4}{\sqrt{7}}$

B. $\frac{8}{\sqrt{7}}$



C. $\frac{8}{7}$

D. $\frac{16}{7}$

Answer: B

Solution:

Solution:

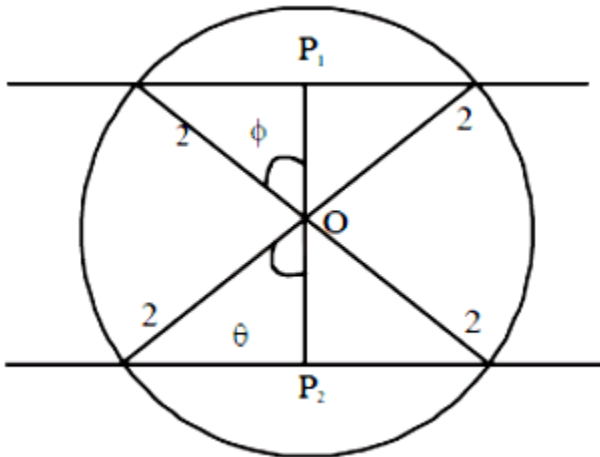

Since $\cos 2\theta = 1/7 \Rightarrow 2\cos^2\theta - 1 = 1/7$

$\Rightarrow 2\cos^2\theta = 8/7$

$\Rightarrow \cos^2\theta = 4/7$

$\Rightarrow \cos^2\theta = \frac{4}{7}$

$\Rightarrow \cos^2\phi = \frac{2}{\sqrt{7}}$

Also, $\sec^2\phi = 7 = \frac{1}{2\cos^2\phi - 1} = 7$

$= \cos^2\phi - 1 = \frac{1}{7} = 2\cos^2\phi = \frac{8}{7} = \cos\phi = \frac{2}{\sqrt{7}}$

$P_1P_2 = r \cos\theta + r \cos\phi = \frac{4}{\sqrt{7}} + \frac{4}{\sqrt{7}} = \frac{8}{\sqrt{7}}$

Question384

If $y = mx + c$ is the normal at a point on the parabola $y^2 = 8x$ whose focal distance is 8 units, then $|c|$ is equal to :

[Online April 9, 2017]

Options:

A. $2\sqrt{3}$

B. $8\sqrt{3}$

C. $10\sqrt{3}$

D. $16\sqrt{3}$

Answer: C

Solution:

Solution:

$$c = -29m - 9m^3 \quad a = 2$$

$$\text{Given } (at^2 - a)^2 + 4a^2t^2 = 64$$

$$\Rightarrow (a(t^2 + 1)) = 8$$

$$\Rightarrow t^2 + 1 = 4$$

$$\Rightarrow t^2 = 3$$

$$\Rightarrow t = \sqrt{3}$$

$$\therefore c = 2 \text{ at } (2 + t^2) = 2\sqrt{3}$$

$$|c| = 10\sqrt{3}$$

Question385

If the common tangents to the parabola, $x^2 = 4y$ and the circle, $x^2 + y^2 = 4$ intersect at the point P, then the distance of P from the origin, is :

[Online April 8, 2017]

Options:

A. $\sqrt{2} + 1$

B. $2(3 + 2\sqrt{2})$

C. $2(\sqrt{2} + 1)$

D. $3 + 2\sqrt{2}$

Answer: C

Solution:

Solution:

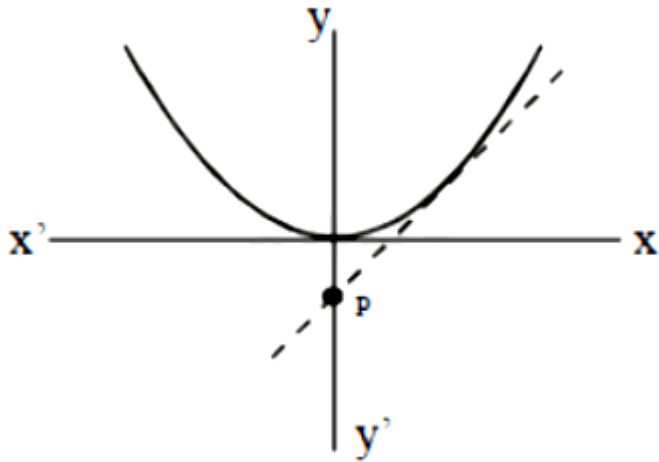

Tangent to $x^2 + y^2 = 4$ is

$$y = mx \pm 2\sqrt{1+m^2}$$

Also, $x^2 = 4y$

$$x^2 = 4mx + 8\sqrt{1+m^2} \text{ or } x^2 = 4mx - 8\sqrt{1+m^2}$$

For $D = 0$

$$\text{we have; } 16m^2 + 4.8\sqrt{1+m^2} = 0$$

$$\Rightarrow m^2 + 2\sqrt{1+m^2} = 0$$

$$\Rightarrow m^2 = -2\sqrt{1+m^2} \Rightarrow m^4 = 4 + 4m^2$$

$$\Rightarrow m^4 - 4m^2 - 4 = 0$$

$$\Rightarrow m^2 = \frac{4 \pm \sqrt{16+16}}{2}$$

$$\Rightarrow m^2 = \frac{4 \pm 4\sqrt{2}}{2}$$

$$\Rightarrow m^2 = 2 + 2\sqrt{2}$$

Question386

The eccentricity of an ellipse having centre at the origin, axes along the co-ordinate axes and passing through the points (4,-1) and (-2,2) is :
[Online April 9, 2017]

Options:

A. $\frac{1}{2}$

B. $\frac{2}{\sqrt{5}}$

C. $\frac{\sqrt{3}}{2}$

D. $\frac{\sqrt{3}}{4}$

Answer: C

Solution:

Solution:

Centre at (0,0)

$$\frac{x^2}{a^2} + \frac{y^2}{b^2} = 1$$

at point (4,-1)

$$\frac{16}{a^2} + \frac{1}{b^2} = 1$$

$$\Rightarrow 16b^2 + a^2 = a^2b^2 \dots (i)$$

at point (-2,2)

$$\frac{4}{a^2} + \frac{4}{b^2} = 1$$

$$\Rightarrow 4b^2 + 4a^2 = a^2b^2 \dots (ii)$$

$$\Rightarrow 16b^2 + a^2 = 4a^2 + 4b^2$$

From equations (1) and (ii)

$$\Rightarrow 3a^2 = 12b^2 \Rightarrow a^2 = 4b^2$$

$$b^2 = a^2(1 - e^2)$$

$$\Rightarrow e^2 = \frac{3}{4} \Rightarrow e = \frac{\sqrt{3}}{2}$$

Question387

Consider an ellipse, whose centre is at the origin and its major axis is along the x -axis. If its eccentricity is $\frac{3}{5}$ and the distance between its foci is 6, then the area (in sq. units) of the quadrilateral inscribed in the ellipse, with the vertices as the vertices of the ellipse, is :

[Online April 8, 2017]

Options:

- A. 8
- B. 32
- C. 80
- D. 40

Answer: D

Solution:

Solution:

$$e = 3/5 \text{ \& } 2ae = 6 \Rightarrow a = 5$$

$$\therefore b^2 = a^2(1 - e^2)$$

$$\Rightarrow b^2 = 25(1 - 9/25)$$

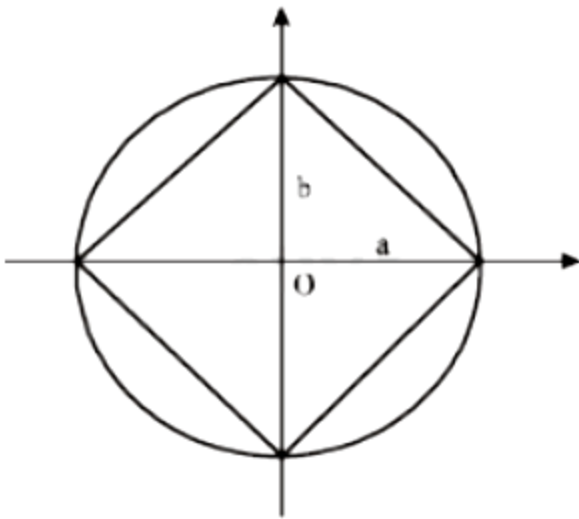

$$\Rightarrow b = 4$$

\therefore area of required quadrilateral

$$= 4(1/2ab) = 2ab = 40$$

Question388

The locus of the point of intersection of the straight lines,

$$tx - 2y - 3t = 0$$

$$x - 2ty + 3 = 0 (t \in \mathbf{R}), \text{ is:}$$

[Online April 8, 2017]

Options:

- A. an ellipse with eccentricity $\frac{2}{\sqrt{5}}$
- B. an ellipse with the length of major axis 6
- C. a hyperbola with eccentricity $\sqrt{5}$
- D. a hyperbola with the length of conjugate axis 3

Answer: D

Solution:

Solution:

Here, $tx - 2y - 3t = 0$ & $x - 2ty + 3 = 0$

On solving, we get;

$$y = \frac{6t}{2t^2 - 2} = \frac{3t}{t^2 - 1} \quad \& \quad x = \frac{3t^2 + 3}{t^2 - 1}$$

Put $t = \tan \theta$

$$\therefore x = -3 \sec 2\theta$$

$$2y = 3(-\tan 2\theta)$$

$$\therefore \sec^2 2\theta - \tan^2 2\theta = 1$$

$$\Rightarrow \frac{x^2}{9} - \frac{y^2}{9/4} = 1$$

which represents a hyperbola

$$\therefore a^2 = 9 \quad \& \quad b^2 = 9/4$$

$$\lambda(T \cdot A.) = 6; \quad e^2 = 1 + \frac{9/4}{9} = 1 + \frac{1}{4} \Rightarrow e = \frac{\sqrt{5}}{2}$$

Question 389

A hyperbola passes through the point $P(\sqrt{2}, \sqrt{3})$ and has foci at $(\pm 2, 0)$. Then the tangent to this hyperbola at P also passes through the point : [2017]

Options:

- A. $(-\sqrt{2}, -\sqrt{3})$
- B. $(3\sqrt{2}, 2\sqrt{3})$
- C. $(2\sqrt{2}, 3\sqrt{3})$

D. $(\sqrt{3}, \sqrt{2})$

Answer: C

Solution:

Solution:

Equation of hyperbola is $\frac{x^2}{a^2} - \frac{y^2}{b^2} = 1$

foci is $(\pm 2, 0) \Rightarrow ae = \pm 2 \Rightarrow a^2 e^2 = 4$

Since $b^2 = a^2(e^2 - 1)$

$b^2 = a^2 e^2 - a^2 \therefore a^2 + b^2 = 4 \dots (i)$

Hyperbola passes through $(\sqrt{2}, \sqrt{3})$

$\therefore \frac{2}{a^2} - \frac{3}{b^2} = 1 \dots (ii)$

$\frac{2}{4 - b^2} - \frac{3}{b^2} = 1$ [from (i)]

$\Rightarrow b^4 + b^2 - 12 = 0$

$\Rightarrow (b^2 - 3)(b^2 + 4) = 0$

$\Rightarrow b^2 = 3$

$b^2 = -4$ (Not possible)

For $b^2 = 3$

$\Rightarrow a^2 = 1 \therefore \frac{x^2}{1} - \frac{y^2}{3} = 1$

Equation of tangent is

$\frac{\sqrt{2}x}{1} - \frac{\sqrt{3}y}{3} = 1$

Clearly $(2\sqrt{2}, 3\sqrt{3})$ satisfies it.

Question390

The radius of a circle, having minimum area, which touches the curve $y = 4 - x^2$ and the lines, $y = |x|$ is :
[2017]

Options:

A. $4(\sqrt{2} + 1)$

B. $2(\sqrt{2} + 1)$

C. $2(\sqrt{2} - 1)$

D. $4(\sqrt{2} - 1)$

E. None of above

Answer: E

Solution:

Solution:

(Let the equation of circle be

$$x^2 + (y - k)^2 = r^2$$

It touches $x - y = 0$

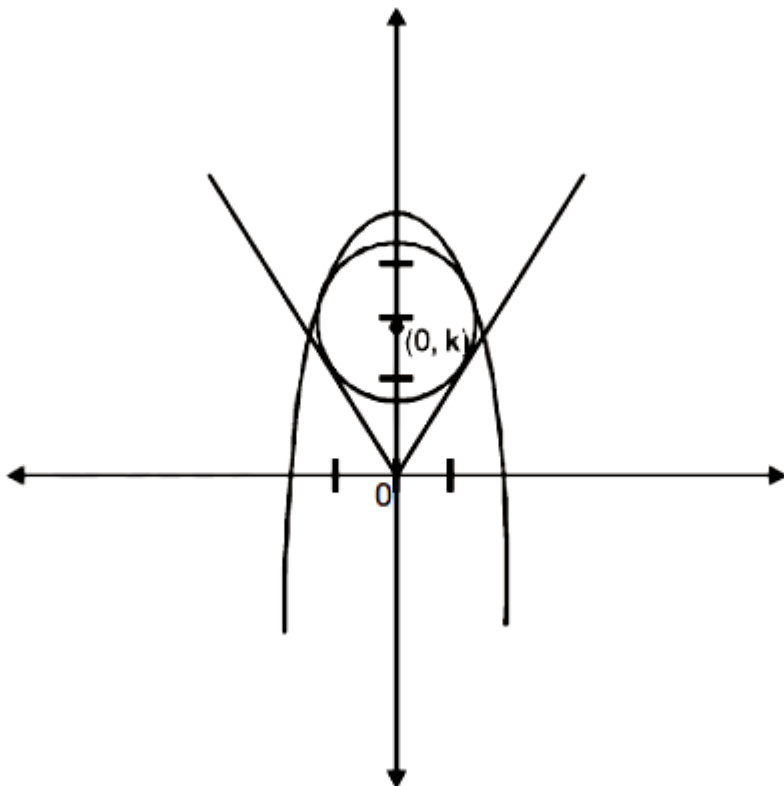

$$\Rightarrow \left| \frac{0 - k}{\sqrt{2}} \right| = r$$

$$\Rightarrow k = r\sqrt{2}$$

\therefore Equation of circle becomes

$$x^2 + (y - k)^2 = \frac{k^2}{2}$$

It touches $y = 4 - x^2$ as well

\therefore Solving the two equations

$$\Rightarrow 4 - y + (y - k)^2 = \frac{k^2}{2}$$

$$\Rightarrow 1y^2 - y(2k + 1) + \frac{k^2}{2} + 4 = 0$$

It will give equal roots $\therefore D = 0$

$$\Rightarrow (2k+1)^2 = 4\left(\frac{k^2}{2} + 4\right)$$

$$\Rightarrow 2k^2 + 4k - 15 = 0$$

$$\Rightarrow k = \frac{-2 + \sqrt{34}}{2}$$

$$\therefore r = \frac{k}{\sqrt{2}} = \frac{-2 + \sqrt{34}}{2\sqrt{2}}$$

Which is not matching with any of the option given here.

Question391

If the tangent at a point on the ellipse $\frac{x^2}{27} + \frac{y^2}{3} = 1$ meets the coordinate axes at A and B, and O is the origin, then the minimum area (in sq. units) of the triangle OAB is:
[Online April 9, 2016]

Options:

A. $3\sqrt{3}$

B. $\frac{9}{2}$

C. 9

D. $\frac{9}{\sqrt{3}}$

Answer: C

Solution:

Solution:

Equation of tangent to ellipse

$$\frac{x}{\sqrt{27}} \cos \theta + \frac{y}{\sqrt{3}} \sin \theta = 1$$

Area bounded by line and co-ordinate axis

$$\Delta = \frac{1}{2} \cdot \frac{\sqrt{27}}{\cos \theta} \cdot \frac{\sqrt{3}}{\sin \theta} = \frac{9}{\sin 2\theta}$$

Δ = will be minimum when $\sin 2\theta = 1$

$$\Delta_{\min} = 9$$

Question392

The eccentricity of the hyperbola whose length of the latus rectum is equal to 8 and the length of its conjugate axis is equal to half of the distance between its foci, is:

[2016]

Options:

A. $\frac{2}{\sqrt{3}}$

B. $\sqrt{3}$

C. $\frac{4}{3}$

D. $\frac{4}{\sqrt{3}}$

Answer: A

Solution:

Solution:

$$\frac{2b^2}{a} = 8 \quad \text{and} \quad 2b = \frac{1}{2}(2ae)$$

$$\Rightarrow 4b^2 = a^2e^2 \Rightarrow 4a^2(e^2 - 1) = a^2e^2$$

$$\Rightarrow 3e^2 = 4 \Rightarrow e = \frac{2}{\sqrt{3}}$$

Question393

A hyperbola whose transverse axis is along the major axis of the conic, $\frac{x^2}{3} + \frac{y^2}{4} = 4$ and has vertices at the foci of this conic. If the eccentricity of the hyperbola is $\frac{3}{2}$, then which of the following points does NOT lie

on it?

[Online April 10, 2016]

Options:

A. $(\sqrt{5}, 2\sqrt{2})$

B. $(0,2)$

C. $(5, 2\sqrt{3})$

D. $(\sqrt{10}, 2\sqrt{3})$

Answer: C

Solution:

$$\frac{x^2}{12} + \frac{y^2}{16} = 1$$
$$e = \sqrt{1 - \frac{12}{16}} = \frac{1}{2}$$

Foci $(0,2)$ & $(0, -2)$

So, transverse axis of hyperbola $= 2b = 4 \Rightarrow b = 2$

$$a^2 = 1^2(e^2 - 1)$$

$$\Rightarrow a^2 = 4 \left(\frac{9}{4} - 1 \right)$$

$$\Rightarrow a^2 = 5$$

\therefore It's equation is

$$\frac{x^2}{5} - \frac{y^2}{4} = -1$$

The point $(5, 2\sqrt{3})$ does not satisfy the above equation.

Question394

Let a and b respectively be the semi transverse and semi conjugate axes of a hyperbola whose eccentricity satisfies the equation

$9e^2 - 18e + 5 = 0$. If $S(5, 0)$ is a focus and $5x = 9$ is the corresponding directrix of this hyperbola, then $a^2 - b^2$ is equal to :

[Online April 9, 2016]

Options:

- A. -7
- B. -5
- C. 5
- D. 7

Answer: A

Solution:

Solution:

$S(5, 0)$ is focus $\Rightarrow ae = 5$ (focus) ——— (a)

$x = \frac{a}{e} \Rightarrow \frac{a}{e} = \frac{9}{5}$ (directrix) ——— (b)

(a) & (b) $\Rightarrow a^2 = 9$ (a)

(a) $\Rightarrow (e) = \frac{5}{3}$

$b^2 = a^2(e^2 - 1) \Rightarrow b^2 = 16$

$a^2 - b^2 = 9 - 16 = -7$

Question395

If one of the diameters of the circle, given by the equation, $x^2 + y^2 - 4x + 6y - 12 = 0$, is a chord of a circle S, whose centre is at $(-3, 2)$, then the radius of S is:

[2016]

Options:

- A. 5
- B. 10
- C. $5\sqrt{2}$
- D. $5\sqrt{3}$

Answer: D

Solution:

Solution:

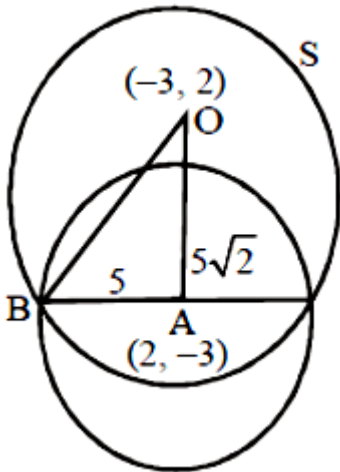

Given, centre of S is $O(-3, 2)$ and centre of given circle is $A(2, -3)$ and radius is 5.

$$OA = 5\sqrt{2}$$

Also $AB = 5$ ($\because AB =$ radius of the given circle)

Using pythagoras theorem in $\triangle OAB$

$$r = 5\sqrt{3}$$

Question396

**Equation of the tangent to the circle, at the point $(1,-1)$ whose centre is the point of intersection of the straight lines $x - y = 1$ and $2x + y = 3$ is:
[Online April 10, 2016]**

Options:

A. $x + 4y + 3 = 0$

B. $3x - y - 4 = 0$

C. $x - 3y - 4 = 0$

D. $4x + y - 3 = 0$

Answer: A

Solution:

Solution:

Point of intersection of lines

$$x - y = 1 \text{ and } 2x + y = 3 \text{ is } \left(\frac{4}{3}, \frac{1}{3} \right)$$

$$\text{Slope of OP} = \frac{\frac{1}{3} + 1}{\frac{4}{3} - 1} = \frac{\frac{4}{3}}{\frac{1}{3}} = 4$$

$$\text{Slope of tangent} = -\frac{1}{4}$$

$$\text{Equation of tangent } y + 1 = -\frac{1}{4}(x - 1)$$

$$4y + 4 = -x + 1$$

$$x + 4y + 3 = 0$$

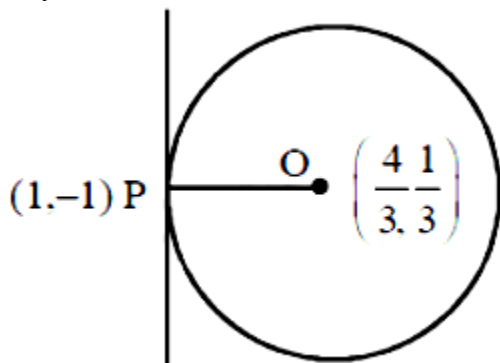
**Question397**

A circle passes through $(-2,4)$ and touches the y -axis at $(0,2)$. Which one of the following equations can represent a diameter of this circle ?
[Online April 9, 2016]

Options:

A. $2x - 3y + 10 = 0$

B. $3x + 4y - 3 = 0$

C. $4x + 5y - 6 = 0$

D. $5x + 2y + 4 = 0$

Answer: A**Solution:**

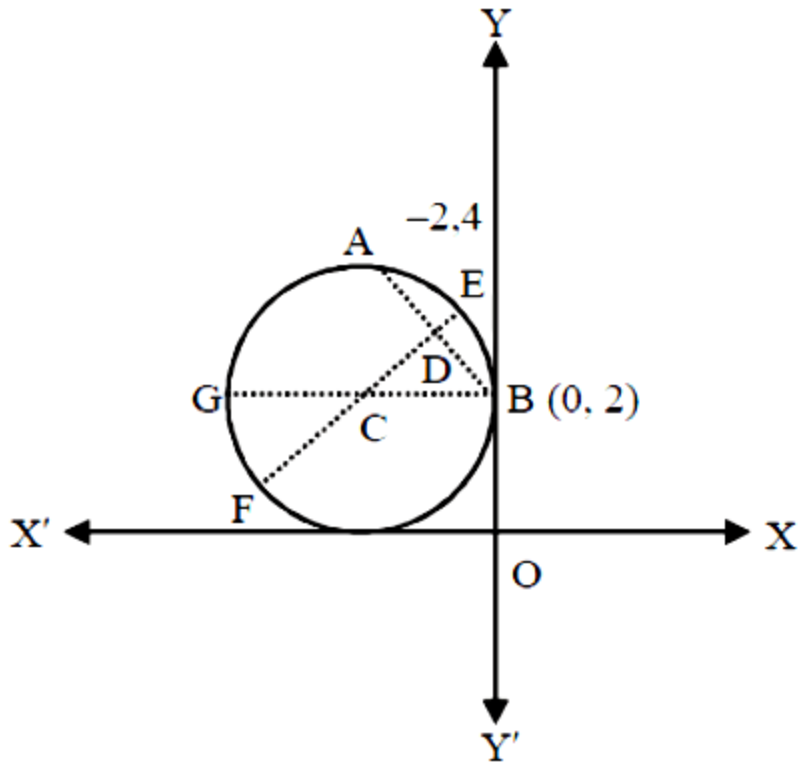

EF = perpendicular bisector of chord AB

BG = perpendicular to y-axis

Here C = centre of the circle

mid-point of chord AB, $D = (-1, 3)$ slope of AB = $\frac{4-2}{-2-0} = -1$

$\therefore EF \perp AB$

\therefore Slope of EF = 1

Equation of EF, $y - 3 = 1(x + 1) \dots (i)$

$\Rightarrow y = x + 4$

Equation of BG

$y = 2 \dots (ii)$

From equations (i) and (ii)

$x = -2, y = 2$

since C be the point of intersection of EF and BG, therefore centre, $C = (-2, 2)$

Now coordinates of centre C satisfy the equation $2x - 3y + 10 = 0$

Hence $2x - 3y + 10 = 0$ is the equation of the diameter

Question398

Let P be the point on the parabola, $y^2 = 8x$ which is at a minimum distance from the centre C of the circle, $x^2 + (y + 6)^2 = 1$. Then the equation of the circle, passing through C and having its centre at P is: [2016]

Options:

A. $x^2 + y^2 - \frac{x}{4} + 2y - 24 = 0$

B. $x^2 + y^2 - 4x + 9y + 18 = 0$

C. $x^2 + y^2 - 4x + 8y + 12 = 0$

D. $x^2 + y^2 - x + 4y - 12 = 0$

Answer: C

Solution:

Solution:

Minimum distance \Rightarrow perpendicular distance $E q^n$ of normal at $p(2t^2, 4t)$

$$y = -tx + 4t + 2t^3$$

It passes through $C(0, -6)$

$$t^3 + 2t + 3 = 0 \Rightarrow t = -1$$

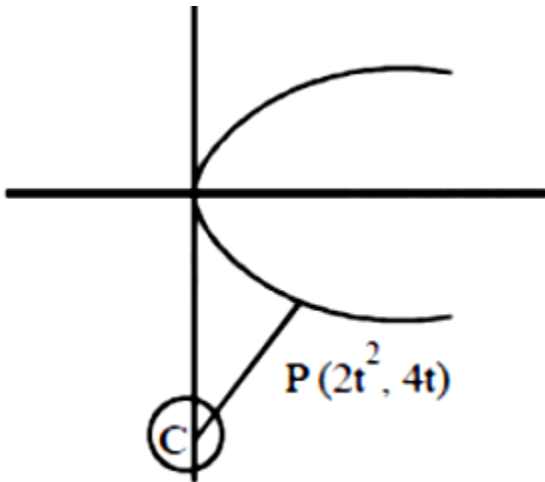

$$\text{Centre of new circle} = P(2t^2, 4t) = P(2, -4)$$

$$\text{Radius} = PC = \sqrt{(2-0)^2 + (-4+6)^2} = 2\sqrt{2}$$

\therefore Equation of circle is :

$$(x-2)^2 + (y+4)^2 = (2\sqrt{2})^2$$

$$\Rightarrow x^2 + y^2 - 4x + 8y + 12 = 0$$

Question399

P and Q are two distinct points on the parabola, $y^2 = 4x$ with parameters t and t_1 respectively. If the normal at P passes through Q, the minimum value of t_1^2 is :
[Online April 10, 2016]

Options:

- A. 8
- B. 4
- C. 6
- D. 2

Answer: A

Solution:

Solution:

$$t_1 = -t - \frac{2}{t}$$

$$t_1^2 = t^2 + \frac{4}{t^2} + 4$$

$$t^2 + \frac{4}{t^2} \geq 2 \sqrt{t^2 \cdot \frac{4}{t^2}} = 4$$

Minimum value of $t_1^2 = 8$

Question400

Locus of the image of the point (2,3) in the line $(2x - 3y + 4) + k(x - 2y + 3) = 0$, $k \in \mathbb{R}$, is a :
[2015]

Options:

- A. circle of radius $\sqrt{2}$.
- B. circle of radius $\sqrt{3}$.

C. straight line parallel to x -axis

D. straight line parallel to y-axis

Answer: A

Solution:

Intersection point of $2x - 3y + 4 = 0$ and $x - 2y + 3 = 0$ is $(1,2)$

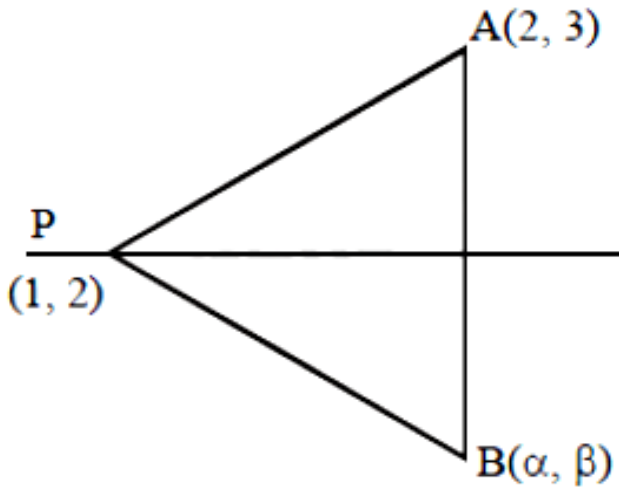

Let image of $A(2, 3)$ is $B(\alpha, \beta)$

Since, P is the fixed point for given family of lines So, $PB = PA$

$$(\alpha - 1)^2 + (\beta - 2)^2 = (2 - 1)^2 + (3 - 2)^2$$

$$(\alpha - 1)^2 + (\beta - 2)^2 = 1 + 1 = 2$$

$$(x - 1)^2 + (y - 2)^2 = (\sqrt{2})^2$$

Compare with

$$(x - a)^2 + (y - b)^2 = r^2$$

Therefore, given locus is a circle with centre $(1,2)$ and radius $\sqrt{2}$.

Question401

The number of common tangents to the circles $x^2 + y^2 - 4x - 6y - 12 = 0$ and $x^2 + y^2 + 6x + 18y + 26 = 0$, is:
[2015]

Options:

- A. 3
- B. 4
- C. 1
- D. 2

Answer: A

Solution:

$$x^2 + y^2 - 4x - 6y - 12 = 0 \dots (i)$$

Centre, $C_1 = (2, 3)$

Radius, $r_1 = 5$ units

$$x^2 + y^2 + 6x + 18y + 26 = 0 \dots (ii)$$

Centre, $C_2 = (-3, -9)$

Radius, $r_2 = 8$ units

$$C_1C_2 = \sqrt{(2+3)^2 + (3+9)^2} = 13 \text{ units}$$

$$r_1 + r_2 = 5 + 8 = 13$$

$$\therefore C_1C_2 = r_1 + r_2$$

Therefore there are three common tangents.

Question402

If the incentre of an equilateral triangle is (1,1) and the equation of its one side is $3x + 4y + 3 = 0$, then the equation of the circumcircle of this triangle is :

[Online April 11, 2015]

Options:

A. $x^2 + y^2 - 2x - 2y - 14 = 0$

B. $x^2 + y^2 - 2x - 2y - 2 = 0$

C. $x^2 + y^2 - 2x - 2y + 2 = 0$

D. $x^2 + y^2 - 2x - 2y - 7 = 0$

Answer: A

Solution:

Solution:

Hint: Note that for an equilateral triangle, circumcentre and incentre coincide. So, circumcentre is (1, 1). Find the inradius. Use this and the figure to get the expression $\sin 30^\circ = \frac{1}{2} = \frac{r}{R}$. This gives $R = 4$.

Now, we have the centre and the radius of the circumcentre. Using these find the equation of the circumcircle of this triangle.

Complete Step-by-step answer:

In this question, we are given that the incentre of an equilateral triangle is (1, 1) and the equation of its one side is $3x + 4y + 3 = 0$

Using this information, we need to find the equation of the circumcircle of this triangle.

First, let us define the incentre and circumcentre.

The incentre of a triangle may be equivalently defined as the point where the internal angle bisectors of the triangle cross, as the point equidistant from the triangle's sides, and as the centre point of the inscribed circle of the triangle.

The circumcentre of a triangle is defined as the point where the perpendicular bisectors of the sides of that particular triangle intersect. In other words, the point of concurrency of the bisector of the sides of a triangle is called the circumcentre.

We know that, for an equilateral triangle, circumcentre and incentre coincide.

Using this property, the circumcentre of the given triangle is (1, 1).

In the shown figure, R is the circumradius of the triangle.

r is the inradius of the triangle.

The shown angle is 30° .

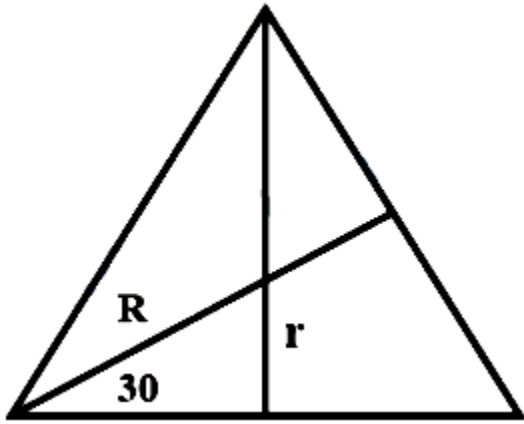

Now, the inradius, r is the distance of $(1, 1)$ from the line $3x + 4y + 3 = 0$

$$\text{So, inradius, } r = \frac{|3 \cdot 1 + 4 \cdot 1 + 3|}{\sqrt{3^2 + 4^2}} = 2$$

$$\text{Now, } \sin 30^\circ = \frac{1}{2} = \frac{r}{R}$$

$$\sin 30^\circ = \frac{1}{2} = \frac{2}{R}$$

$$R = 4$$

Hence, the circumradius, $R = 4$ units.

Now, we know that general equation of circle is: $x^2 + y^2 + 2gx + 2fy + c = 0$ with centre at $(-g, -f)$ and radius $= \sqrt{g^2 + f^2 - c}$

Now the circumcircle has its centre at $(1, 1)$ and has the radius $R = 4$ units. We will substitute these values in the general equation above. So, the equation of the circumcircle is:

$$x^2 + y^2 - 2x - 2y - 14 = 0$$

So, option (b) is correct.

Note: It is important to know the following: the incentre of a triangle may be equivalently defined as the point where the internal angle bisectors of the triangle cross and that for an equilateral triangle, circumcentre and incentre coincide.

Question403

If a circle passing through the point $(-1,0)$ touches y -axis at $(0, 2)$, then the length of the chord of the circle along the x -axis is:

[Online April 11, 2015]

Options:

A. $\frac{3}{2}$

B. 3

C. $\frac{5}{2}$

D. 5

Answer: B

Solution:

Solution:

Let 'h' be the radius of the circle and since circle touches y-axis at (0,2) therefore centre = (h, 2)

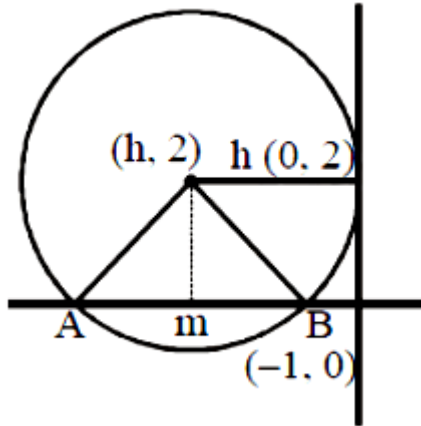

Now, eqn of circle is

$$(h+1)^2 + 2^2 = h^2$$

$$\Rightarrow 2h + 5 = 0$$

$$h = -\frac{5}{2}$$

From the figure, it is clear that AB is the chord along x -axis

$$\therefore AB = 2(AM) = 2 \sqrt{\frac{25}{4} - 4} = 2 \left(\frac{3}{2} \right) = 3$$

Question404

Let the tangents drawn to the circle, $x^2 + y^2 = 16$ from the point $P(0, h)$ meet the x -axis at point A and B. If the area of $\triangle APB$ is minimum, then h is equal to :

[Online April 10, 2015]

Options:

A. $4\sqrt{2}$

B. $3\sqrt{3}$

C. $3\sqrt{2}$

D. $4\sqrt{3}$

Answer: A

Solution:

Solution:

$$OP = \frac{4}{\sin \theta}$$

$$OB = \frac{4}{\cos \theta}$$

$$\text{Area} = OP \times OB = \frac{16}{\sin \theta \cos \theta} = \frac{32}{\sin 2\theta}$$

least value $\sin 2\theta = 1$; $\theta = 45^\circ$

$$\text{So, } h = \frac{4}{\sin 45^\circ} = 4\sqrt{2}$$

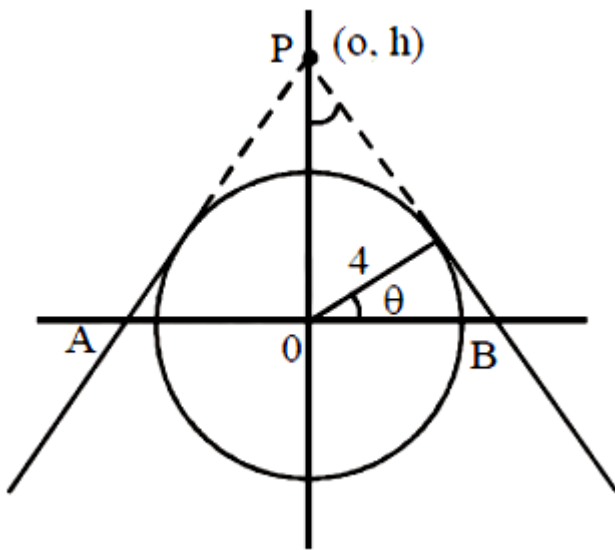

Question405

If $y + 3x = 0$ is the equation of a chord of the circle, $x^2 + y^2 - 30x = 0$, then the equation of the circle with this chord as diameter is :
[Online April 10, 2015]

Options:



A. $x^2 + y^2 + 3x + 9y = 0$

B. $x^2 + y^2 + 3x - 9y = 0$

C. $x^2 + y^2 - 3x - 9y = 0$

D. $x^2 + y^2 - 3x + 9y = 0$

Answer: D

Solution:

Solution:

Given that $y + 3x = 0$ is the equation of a chord of the circle then

$$y = -3x \dots (i)$$

$$(x^2) + (-3x)^2 - 30x = 0$$

$$10x^2 - 30x = 0$$

$$10x(x - 3) = 0 \quad x = 0, y = 0$$

so the equation of the circle is

$$(x - 3)(x - 0) + (y + 9)(y - 0) = 0$$

$$x^2 - 3x + y^2 + 9y = 0$$

$$x^2 + y^2 - 3x + 9y = 0$$

Question406

The largest value of r for which the region represented by the set $\{\omega \in \mathbb{C} \mid |\omega - 4 - i| \leq r\}$ is contained in the region represented by the set $(z \in \mathbb{C} \mid |z - 1| \leq |z + i|)$, is equal to:

[Online April 10, 2015]

Options:

A. $\frac{5}{2}\sqrt{2}$

B. $2\sqrt{2}$

C. $\frac{3}{2}\sqrt{2}$

D. $\sqrt{17}$

Answer: A

Solution:

Solution:

Radius

$$CP = \frac{4+1}{\sqrt{2}} = \frac{5}{\sqrt{2}} = \frac{5\sqrt{2}}{2}$$

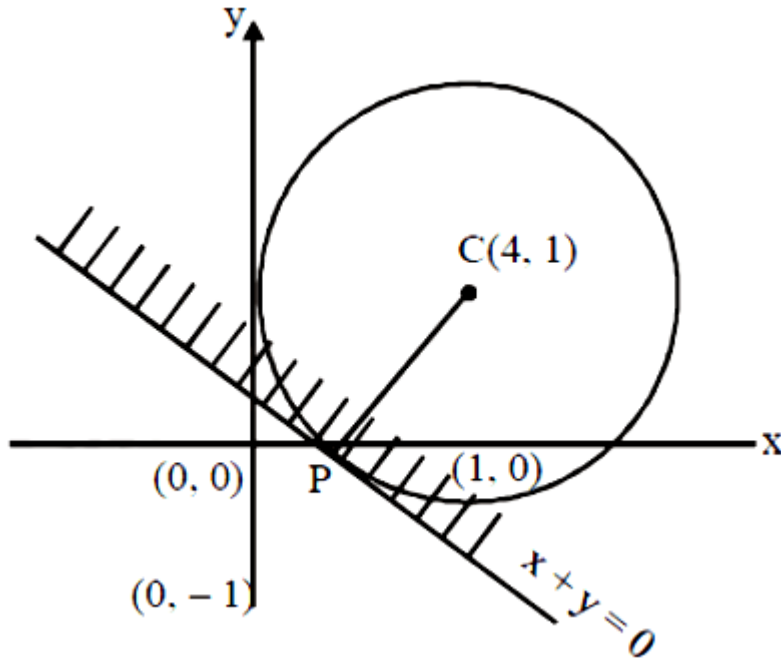

Question407

Let O be the vertex and Q be any point on the parabola, $x^2 = 8y$. If the point P divides the line segment OQ internally in the ratio 1 : 3, then locus of P is :

[2015]

Options:

A. $y^2 = 2x$

B. $x^2 = 2y$

C. $x^2 = y$

D. $y^2 = x$

Answer: B

Solution:

Solution:

Let $P(h, k)$ divides OQ in the ratio $1:3$

Let any point Q on $x^2 = 8y$ is $(4t, 2t^2)$

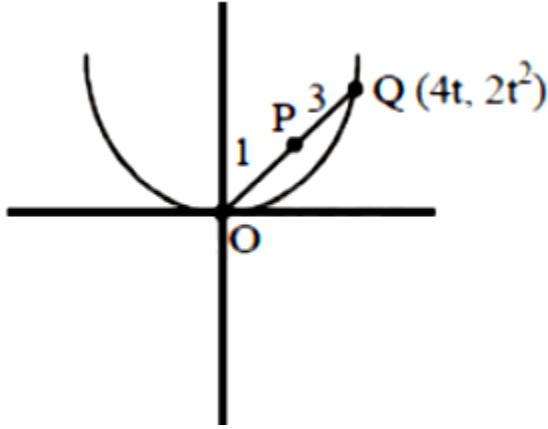

Then by section formula

$$\Rightarrow k = \frac{t^2}{2} \text{ and } h = t$$

$$\Rightarrow 2k = h^2$$

Required locus of P is $x^2 = 2y$

Question408

Let PQ be a double ordinate of the parabola, $y^2 = -4x$, where P lies in the second quadrant. If R divides PQ in the ratio $2:1$ then the locus of R is :

[Online April 11, 2015]

Options:

A. $3y^2 = -2x$

B. $3y^2 = 2x$

C. $9y^2 = 4x$

D. $9y^2 = -4x$

Answer: D

Solution:

Solution:

Let $P(-at_1^2, 2at_1)$, $Q(-at_1^2, -2at_1)$ and $R(h, k)$ By using section formula, we have

$$h = -at_1^2, k = \frac{-2at_1}{3}$$

$$k = -\frac{2at_1}{3}$$

$$\Rightarrow 3k = -2at$$

$$\Rightarrow 9k^2 = 4a^2t_1^2 = 4a(-h)$$

$$\Rightarrow 9k^2 = -4ah$$

$$\Rightarrow 9k^2 = -4h \Rightarrow 9y^2 = -4x$$

Question409

The area (in sq. units) of the quadrilateral formed by the tangents at the end points of the latera recta to the ellipse

$$\frac{x^2}{9} + \frac{y^2}{5} = 1, \text{ is :}$$

[2015]

Options:

A. $\frac{27}{2}$

B. 27

C. $\frac{27}{4}$

D. 18

Answer: B

Solution:

The end point of latus rectum of ellipse

$\frac{x^2}{a^2} + \frac{y^2}{b^2} = 1$ in first quadrant is $(ae, \frac{b^2}{a})$ and the tangent at this point intersects x-axis at $(\frac{a}{e}, 0)$ and y-axis at $(0, a)$.

The given ellipse is $\frac{x^2}{9} + \frac{y^2}{5} = 1$

Then $a^2 = 9, b^2 = 5$

$$\Rightarrow e = \sqrt{1 - \frac{5}{9}} = \frac{2}{3}$$

\therefore End point of latus rectum in first quadrant is $L(2, 5/3)$

Equation of tangent at L is $\frac{2x}{9} + \frac{y}{3} = 1$

[\because It meets x-axis at $A(9/2, 0)$ and y-axis at $B(0, 3)$]

$$\text{Area of } \triangle OAB = \frac{1}{2} \times \frac{9}{2} \times 3 = \frac{27}{4}$$

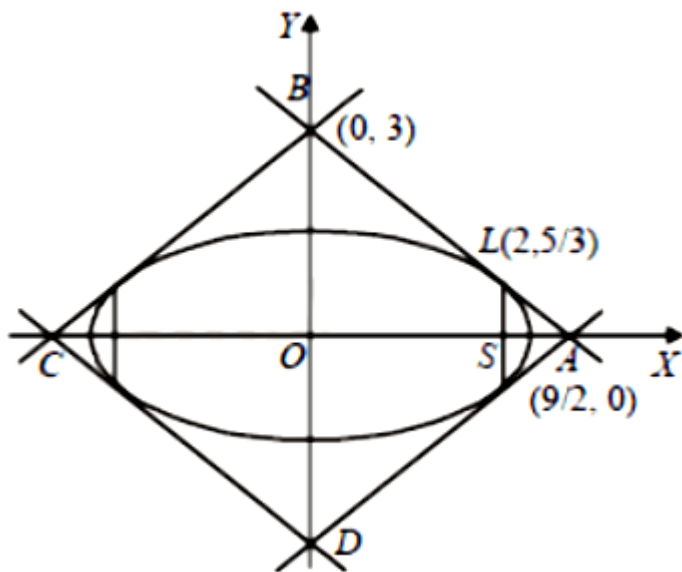

By symmetry area of quadrilateral

$$= 4 \times (\text{Area } \triangle OAB) = 4 \times \frac{27}{4} = 27 \text{ sq. units}$$

Question 410

If the distance between the foci of an ellipse is half the length of its latus rectum, then the eccentricity of the ellipse is:

[Online April 11, 2015]

Options:

A. $\frac{2\sqrt{2}-1}{2}$



B. $\sqrt{2} - 1$

C. $\frac{1}{2}$

D. $\frac{\sqrt{2}-1}{2}$

Answer: B

Solution:

Solution:

Focus of an ellipse is given as $(\pm ae, 0)$ Distance between them = $2ae$

According to the question, $2ae = \frac{b^2}{a}$

$$\Rightarrow 2a^2e = b^2 = a^2(1 - e^2)$$

$$\Rightarrow 2e = 1 - e^2 \Rightarrow (e + 1)^2 = 2 \Rightarrow e = \sqrt{2} - 1$$

Question411

An ellipse passes through the foci of the hyperbola, $9x^2 - 4y^2 = 36$ and its major and minor axes lie along the transverse and conjugate axes of the hyperbola respectively. If the product of eccentricities of the two conics is $\frac{1}{2}$, then which of the following points does not lie on the ellipse?

[Online April 10, 2015]

Options:

A. $\left(\sqrt{\frac{13}{2}}, \sqrt{6} \right)$

B. $\left(\frac{\sqrt{39}}{2}, \sqrt{3} \right)$

C. $\left(\frac{1}{2}\sqrt{13}, \frac{\sqrt{3}}{2} \right)$

D. $(\sqrt{13}, 0)$

Answer: C

Solution:

Solution:

Equation of hyperbola is

$$\frac{x^2}{4} - \frac{y^2}{9} = 1$$

$$\text{Its Foci} = (\pm\sqrt{13}, 0) \quad e = \frac{\sqrt{13}}{2}$$

If e_1 be the eccentricity of the ellipse, then

$$e_1 \times \frac{\sqrt{13}}{2} = \frac{1}{2} \Rightarrow e_1 = \frac{1}{\sqrt{13}}$$

Equation of ellipse is

$$\frac{x^2}{a^2} + \frac{y^2}{b^2} = 1$$

Since ellipse passes through the foci $(\pm\sqrt{13}, 0)$ of the hyperbola, therefore

$$a^2 = 13$$

$$\text{Now } \sqrt{a^2 - b^2} = ae_1$$

$$\therefore 13 - b^2 = 1$$

$$\Rightarrow b^2 = 12$$

Hence, equation of ellipse is

$$\frac{x^2}{13} + \frac{y^2}{12} = 1$$

Now putting the coordinate of the point $\left(\frac{\sqrt{13}}{2}, \frac{\sqrt{3}}{2}\right)$ in the equation of the ellipse, we get

$$\frac{13}{4 \times 13} + \frac{3}{4 \times 12} = 1$$

$$\Rightarrow \frac{1}{4} + \frac{1}{16} = 1, \text{ which is not true,}$$

Question412

Let C be the circle with centre at (1,1) and radius = 1. If T is the circle centred at (0, y), passing through origin and touching the circle C externally, then the radius of T is equal to [2014]

Options:

- A. $\frac{1}{2}$
- B. $\frac{1}{4}$
- C. $\frac{\sqrt{3}}{\sqrt{2}}$
- D. $\frac{\sqrt{3}}{2}$

Answer: B

Solution:

Solution:

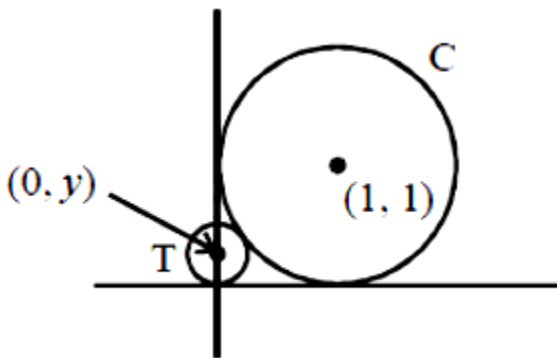

Equation of circle

$$C \equiv (x - 1)^2 + (y - 1)^2 = 1$$

Radius of T = $|y|$ T touches C externally therefore,

Distance between the centres = sum of their radii

$$\Rightarrow \sqrt{(0 - 1)^2 + (y - 1)^2} = 1 + |y|$$

$$\Rightarrow (0 - 1)^2 + (y - 1)^2 = (1 + |y|)^2$$

$$\Rightarrow 1 + y^2 + 1 - 2y = 1 + y^2 + 2|y| \quad 2|y| = 1 - 2y$$

$$\text{If } y > 0 \text{ then } 2y = 1 - 2y \Rightarrow y = \frac{1}{4}$$

$$\text{If } y < 0 \text{ then } -2y = 1 - 2y \Rightarrow 0 = 1 \text{ (not possible)}$$

$$\therefore y = \frac{1}{4}$$

Question413

The equation of circle described on the chord $3x + y + 5 = 0$ of the circle $x^2 + y^2 = 16$ as diameter is:

[Online April 19, 2014]

Options:

A. $x^2 + y^2 + 3x + y - 11 = 0$

B. $x^2 + y^2 + 3x + y + 1 = 0$

C. $x^2 + y^2 + 3x + y - 2 = 0$

D. $x^2 + y^2 + 3x + y - 22 = 0$

Answer: A

Solution:

Solution:

Given circle is $x^2 + y^2 - 16 = 0$

Eqn of chord say AB of given circle is

$$3x + y + 5 = 0$$

Equation of required circle is

$$x^2 + y^2 - 16 + \lambda(3x + y + 5) = 0$$

$$\Rightarrow x^2 + y^2 + (3\lambda)x + (\lambda)y + 5\lambda - 16 = 0$$

$$\text{Centre } C = \left(\frac{-3\lambda}{2}, \frac{-\lambda}{2} \right).$$

If line AB is the diameter of circle (1), then

$$C \left(\frac{-3\lambda}{2}, \frac{-\lambda}{2} \right) \text{ will lie on line AB.}$$

$$\text{i.e. } 3 \left(\frac{-3\lambda}{2} \right) + \left(\frac{-\lambda}{2} \right) + 5 = 0$$

$$\Rightarrow -\frac{9\lambda - \lambda}{2} + 5 = 0 \Rightarrow \lambda = 1$$

Hence, required eqn of circle is

$$x^2 + y^2 + 3x + y + 5 - 16 = 0$$

$$\Rightarrow x^2 + y^2 + 3x + y - 11 = 0$$

Question414

For the two circles $x^2 + y^2 = 16$ and $x^2 + y^2 - 2y = 0$, there is/are
[Online April 12, 2014]

Options:

- A. one pair of common tangents
- B. two pair of common tangents
- C. three pair of common tangents
- D. no common tangent

Answer: D

Solution:

Solution:

Let, $x^2 + y^2 = 16$ or $x^2 + y^2 = 4^2$

radius of circle $r_1 = 4$, centre $C_1(0, 0)$

we have, $x^2 + y^2 - 2y = 0$

$\Rightarrow x^2 + (y^2 - 2y + 1) - 1 = 0$ or $x^2 + (y - 1)^2 = 1^2$

Radius 1, centre $C_2(0, 1)$

$$|C_1C_2| = 1$$

$$|r_2 - r_1| = |4 - 1| = 3$$

$$|C_1C_2| < |r_2 - r_1|$$

Question415

The set of all real values of λ for which exactly two common tangents can be drawn to the circles $x^2 + y^2 - 4x - 4y + 6 = 0$ and

$x^2 + y^2 - 10x - 10y + \lambda = 0$ is the interval:

[Online April 11, 2014]

Options:

- A. (12,32)
- B. (18,42)
- C. (12,24)
- D. (18,48)

Answer: B

Solution:

Solution:

The equations of the circles are

$$x^2 + y^2 - 10x - 10y + \lambda = 0$$

$$\text{and } x^2 + y^2 - 4x - 4y + 6 = 0 \dots (2)$$

$$C_1 = \text{centre of (1)} = (5, 5)$$

$$C_2 = \text{centre of (2)} = (2, 2)$$

d = distance between centres

$$= C_1C_2 = \sqrt{9+9} = \sqrt{18}$$

$$r_1 = \sqrt{50-\lambda}, r_2 = \sqrt{2}$$

For exactly two common tangents we have

$$r_1 - r_2 < C_1C_2 < r_1 + r_2$$

$$\Rightarrow \sqrt{50-\lambda} - \sqrt{2} < 3\sqrt{2} < \sqrt{50-\lambda} + \sqrt{2}$$

$$\Rightarrow \sqrt{50-\lambda} - \sqrt{2} < 3\sqrt{2} \text{ or } 3\sqrt{2} < \sqrt{50-\lambda} + \sqrt{2}$$

$$\Rightarrow \sqrt{50-\lambda} < 4\sqrt{2} \text{ or } 2\sqrt{2} < \sqrt{50-\lambda}$$

$$\Rightarrow 50 - \lambda < 32 \text{ or } 8 < 50 - \lambda$$

$$\Rightarrow \lambda > 18 \text{ or } \lambda < 42$$

Required interval is (18,42)

Question416

If the point (1,4) lies inside the circle $x^2 + y^2 - 6x - 10y + P = 0$ and the circle does not touch or intersect the coordinate axes, then the set of all possible values of P is the interval:

[Online April 9, 2014]

Options:

A. (0,25)

B. (25,39)

C. (9,25)

D. (25,29)

Answer: D

Solution:

Solution:

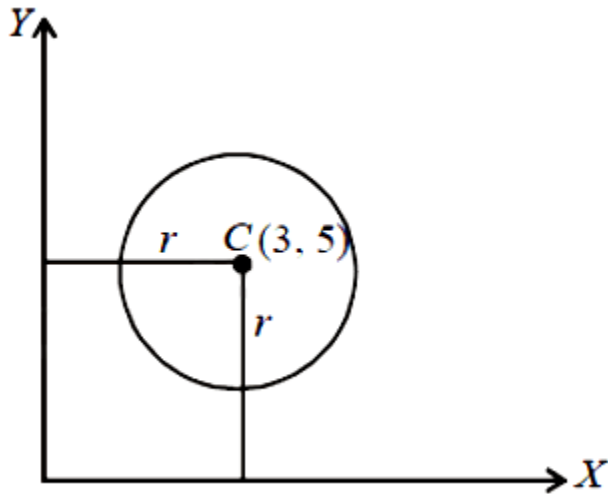

The equation of circle is

$$x^2 + y^2 - 6x - 10y + P = 0 \dots (i)$$

$$(x - 3)^2 + (y - 5)^2 = (\sqrt{34 - P})^2$$

Centre (3,5) and radius $r = \sqrt{34 - P}$

If circle does not touch or intersect the x -axis then radius $r < y$ - coordinate of centre C or $\sqrt{34 - P} < 5$
 $\Rightarrow 34 - P < 25$

$$\Rightarrow P > 9$$

Also if the circle does not touch or intersect x -axis the radius $r < x$ -coordinate of centre C. or

$$\sqrt{34 - P} < 3 \Rightarrow 34 - P < 9 \Rightarrow P > 25 \dots (iii)$$

If the point (1,4) is inside the circle, then its distance from centre C $< r$

. or

$$\sqrt{[(3 - 1)^2 + (5 - 4)^2]} < \sqrt{34 - P}$$

$$\Rightarrow 5 < 34 - P$$

$$\Rightarrow P < 29 \dots (iv)$$

Now all the conditions (ii), (iii) and (iv) are satisfied if $25 < P < 29$ which is required value of P.

Question417

Let a and b be any two numbers satisfying $\frac{1}{a^2} + \frac{1}{b^2} = \frac{1}{4}$.

Then, the foot of perpendicular from the origin on the variable line,

$$\frac{x}{a} + \frac{y}{b} = 1, \text{ lies on:}$$

[Online April 9, 2014]

Options:

A. a hyperbola with each semi-axis = $\sqrt{2}$

B. a hyperbola with each semi-axis = 2

C. a circle of radius = 2

D. a circle of radius = $\sqrt{2}$

Answer: C

Solution:

Solution:

Let the foot of the perpendicular from (0,0) on the

variable line $\frac{x}{a} + \frac{y}{b} = 1$ is (x_1, y_1)

Hence, perpendicular distance of the variable line

$\frac{x}{a} + \frac{y}{b} = 1$ from the point $O(0, 0) = OA$

$$\Rightarrow 4 = x_1^2 + y_1^2 \left[\because \frac{1}{a^2} + \frac{1}{b^2} = \frac{1}{4} \right]$$

which is equation of a circle with radius 2 .

Hence (x_1, y_1) i.e., the foot of the perpendicular from the point (0,0) to the variable line $\frac{x}{a} + \frac{y}{b} = 1$ lies on a circle with radius = 2

Question418

The slope of the line touching both the parabolas $y^2 = 4x$ and $x^2 = -32y$ is

[2014]

Options:

A. $\frac{1}{8}$

B. $\frac{2}{3}$

C. $\frac{1}{2}$

D. $\frac{3}{2}$

E.

Answer: C

Solution:

Solution:

Given parabolas are

$$y^2 = 4x \dots (1)$$

$$x^2 = -32y \dots (2)$$

Let m be slope of common tangent Equation of tangent of parabola (1)

$$y = mx + \frac{1}{m} \dots (i)$$

Equation of tangent of parabola (2)

$$y = mx + 8m^2 \dots (ii)$$

(i) and (ii) are identical

$$\Rightarrow \frac{1}{m} = 8m^2 \Rightarrow m^3 = \frac{1}{8} \Rightarrow m = \frac{1}{2}$$

ALTERNATIVEMETHOD:

Let tangent to $y^2 = 4x$ be $y = mx + \frac{1}{m}$

Since this is also tangent to $x^2 = -32y$

$$\therefore x^2 = -32 \left(mx + \frac{1}{m} \right)$$

$$\Rightarrow x^2 + 32mx + \frac{32}{m} = 0$$

Now, $D = 0$

$$(32)^2 - 4 \left(\frac{32}{m} \right) = 0$$

$$\Rightarrow m^3 = \frac{4}{32} \Rightarrow m = \frac{1}{2}$$

Question419

A chord is drawn through the focus of the parabola $y^2 = 6x$ such that its distance from the vertex of this parabola is $\frac{\sqrt{5}}{2}$, then its slope can be:

[Online April 19, 2014]

Options:

A. $\frac{\sqrt{5}}{2}$

B. $\frac{\sqrt{3}}{2}$

C. $\frac{2}{\sqrt{5}}$

D. $\frac{2}{\sqrt{3}}$

Answer: A

Solution:

Solution:

Equation of parabola, $y^2 = 6x$

$$\Rightarrow y^2 = 4 \times \frac{3}{2}x$$

$$\therefore \text{Focus} = \left(\frac{3}{2}, 0 \right)$$

Let equation of chord passing through focus be $ax + by + c = 0 \dots (1)$

Since chord is passing through $\left(\frac{3}{2}, 0 \right)$

$$\therefore \text{Put } x = \frac{3}{2}, y = 0 \text{ in eqn (1), we get } \frac{3}{2}a + c = 0$$

$$\Rightarrow c = -\frac{3}{2}a \dots (2)$$

distance of chord from origin is $\frac{\sqrt{5}}{2} \frac{\sqrt{5}}{2}$

$$= \left| \frac{a(0) + b(0) + c}{\sqrt{a^2 + b^2}} \right| = \frac{c}{\sqrt{a^2 + b^2}}$$

$$\frac{5}{4} = \frac{c^2}{a^2 + b^2}$$

$$\Rightarrow a^2 + b^2 = \frac{4}{5}c^2$$

Putting value of c from (2), we get

$$a^2 + b^2 = \frac{4}{5} \times \frac{9}{4}a^2$$

$$b^2 = \frac{9}{5}a^2 - a^2 = \frac{4}{5}a^2$$

$$\frac{a^2}{b^2} = \frac{5}{4}, \frac{a}{b} = \pm \frac{\sqrt{5}}{2}$$

$$\text{Slope of chord, } \frac{dy}{dx} = -\frac{a}{b} = -\left(\frac{\pm\sqrt{5}}{2} \right) = \mp \frac{\sqrt{5}}{2}$$

Question420

Two tangents are drawn from a point $(-2,-1)$ to the curve, $y^2 = 4x$. If α is the angle between them, then $|\tan \alpha|$ is equal to:

[Online April 12, 2014]

Options:

A. $\frac{1}{3}$

B. $\frac{1}{\sqrt{3}}$

C. $\sqrt{3}$

D. 3

Answer: D

Solution:

Solution:

The locus of the point of intersection of tangents to the parabola $y^2 = 4ax$ inclined at an angle α to each other is

$$\tan^2 \alpha (x + a)^2 = y^2 - 4ax$$

Given equation of Parabola $y^2 = 4x$ {a = 1}

Point of intersection $(-2,-1)$

$$\tan^2 \alpha (-2 + 1)^2 = (-1)^2 - 4 \times 1 \times (-2)$$

$$\Rightarrow \tan^2 \alpha = 9$$

$$\Rightarrow \tan \alpha = \pm 3$$

$$\Rightarrow |\tan \alpha| = 3$$

Question421

Let L_1 be the length of the common chord of the curves $x^2 + y^2 = 9$ and $y^2 = 8x$, and L_2 be the length of the latus rectum of $y^2 = 8x$, then:

[Online April 11, 2014]

Options:

A. $L_1 > L_2$

B. $L_1 = L_2$

C. $L_1 < L_2$

D. $\frac{L_1}{L_2} = \sqrt{2}$

Answer: C

Solution:

Solution:

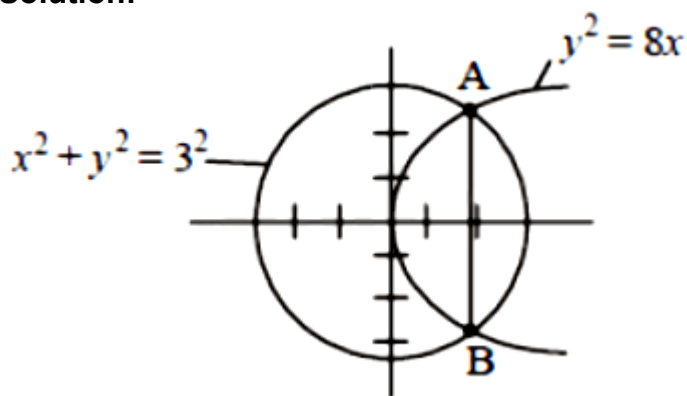

We have $x^2 + (8x) = 9$

$$x^2 + 9x - x - 9 = 0$$

$$x(x + 9) - 1(x + 9) = 0$$

$$(x + 9)(x - 1) = 0$$

$$x = -9, 1$$

$$\text{for } x = 1, y = \pm 2\sqrt{2x} = \pm 2\sqrt{2}$$

$$L_1 = \text{Length of AB} = \sqrt{(2\sqrt{2} + 2\sqrt{2})^2 + (1 - 1)^2} = 4\sqrt{2}$$

$$L_2 = \text{Length of latus rectum} = 4a = 4 \times 2 = 8$$

$$L_1 < L_2$$

Question422

The locus of the foot of perpendicular drawn from the centre of the ellipse $x^2 + 3y^2 = 6$ on any tangent to it is [2014]

Options:



A. $(x^2 + y^2)^2 = 6x^2 + 2y^2$

B. $(x^2 + y^2)^2 = 6x^2 - 2y^2$

C. $(x^2 - y^2)^2 = 6x^2 + 2y^2$

D. $(x^2 - y^2)^2 = 6x^2 - 2y^2$

Answer: A

Solution:

Solution:

Given equation of ellipse can be written as

$$\frac{x^2}{6} + \frac{y^2}{2} = 1$$

$$\Rightarrow a^2 = 6, b^2 = 2$$

Now, equation of any variable tangent is

$$y = mx \pm \sqrt{a^2m^2 + b^2} \dots (i)$$

where m is slope of the tangent

So, equation of perpendicular line drawn from centre to tangent is

$$y = \frac{-x}{m} \dots (ii)$$

Eliminating m, we get

$$(x^4 + y^4 + 2x^2y^2) = a^2x^2 + b^2y^2$$

$$\Rightarrow (x^2 + y^2)^2 = a^2x^2 + b^2y^2$$

$$\Rightarrow (x^2 + y^2)^2 = 6x^2 + 2y^2$$

Question423

A stair-case of length l rests against a vertical wall and a floor of a room. Let P be a point on the stair-case, nearer to its end on the wall, that divides its length in the ratio 1: 2 . If the stair-case begins to slide on the floor, then the locus of P is:

[Online April 11, 2014]

Options:

A. an ellipse of eccentricity $\frac{1}{2}$



B. an ellipse of eccentricity $\frac{\sqrt{3}}{2}$

C. a circle of radius $\frac{1}{2}$

D. a circle of radius $\frac{\sqrt{3}}{2} - 1$

Answer: B

Solution:

Solution:

Let point A(a, 0) is on x-axis and B(0, b) is on y-axis.

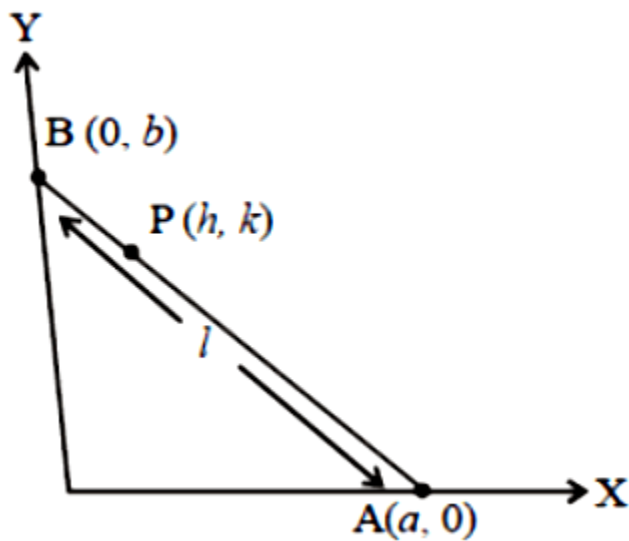

Let P(h, k) divides AB in the ratio 1: 2 . So, by section formula

$$h = \frac{2(0) + 1(a)}{1 + 2} = \frac{a}{3}$$

$$k = \frac{2(b) + 1(0)}{3} = \frac{2b}{3}$$

$$\Rightarrow a = 3h \text{ and } b = \frac{3k}{2}$$

$$\text{Now, } a^2 + b^2 = 1^2$$

$$\Rightarrow 9h^2 + \frac{9k^2}{4} = 1^2$$

$$\Rightarrow \frac{h^2}{\left(\frac{1}{3}\right)^2} + \frac{k^2}{\left(\frac{2}{3}\right)^2} = 1$$

$$\text{Now } e = \sqrt{1 - \left(\frac{1^2}{9} \times \frac{9}{4 \cdot 1^2}\right)} = \sqrt{1 - \frac{1}{4}} = \frac{\sqrt{3}}{2}$$

Thus, required locus of P is an ellipse with eccentricity $\frac{\sqrt{3}}{2}$

Question424

If OB is the semi-minor axis of an ellipse, F_1 and F_2 are its foci and the angle between F_1B and F_2B is a right angle, then the square of the eccentricity of the ellipse is:

[Online April 9, 2014]

Options:

- A. $\frac{1}{2}$
- B. $\frac{1}{\sqrt{2}}$
- C. $\frac{1}{2\sqrt{2}}$
- D. $\frac{1}{4}$

Answer: A

Solution:

Solution:

Let $\frac{x^2}{a^2} + \frac{y^2}{b^2} = 1$ be the equation of ellipse.

Given that F_1B and F_2B are perpendicular to each other. Slope of $F_1B \times$ slope of $F_2B = -1$

$$\left(\frac{0-b}{-ae-0} \right) \times \left(\frac{0-b}{ae-0} \right) = -1$$

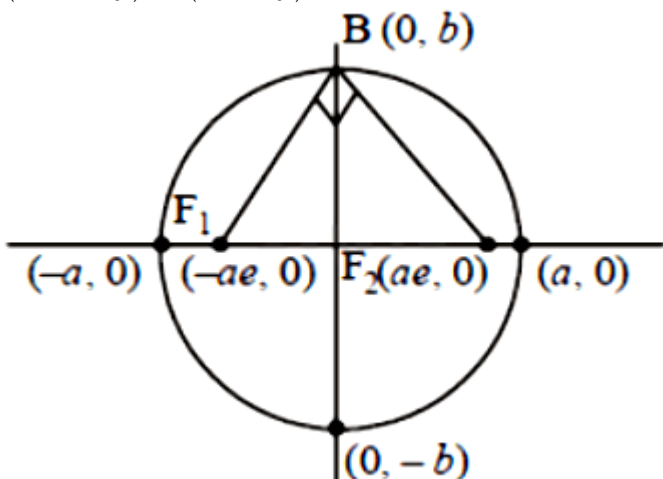

$$\left(\frac{b}{ae}\right) \times \left(\frac{-b}{ae}\right) = -1$$

$$b^2 = a^2 e^2$$

$$e^2 = \frac{b^2}{a^2}$$

$$1 - \frac{b^2}{a^2} = \frac{b^2}{a^2}$$

$$1 = 2 \frac{b^2}{a^2} \Rightarrow \frac{b^2}{a^2} = \frac{1}{2}$$

$$e^2 = 1 - \frac{b^2}{a^2} = 1 - \frac{1}{2} = \frac{1}{2}$$

$$e^2 = \frac{1}{2}$$

No common tangents for these two circles.

Question425

The tangent at an extremity (in the first quadrant) of latus rectum of the hyperbola $\frac{x^2}{4} - \frac{y^2}{5} = 1$, meet x -axis and y-axis at A and B respectively. Then $(OA)^2 - (OB)^2$, where O is the origin, equals: [Online April 19, 2014]

Options:

A. $-\frac{20}{9}$

B. $\frac{16}{9}$

C. 4

D. $-\frac{4}{3}$

Answer: A

Solution:

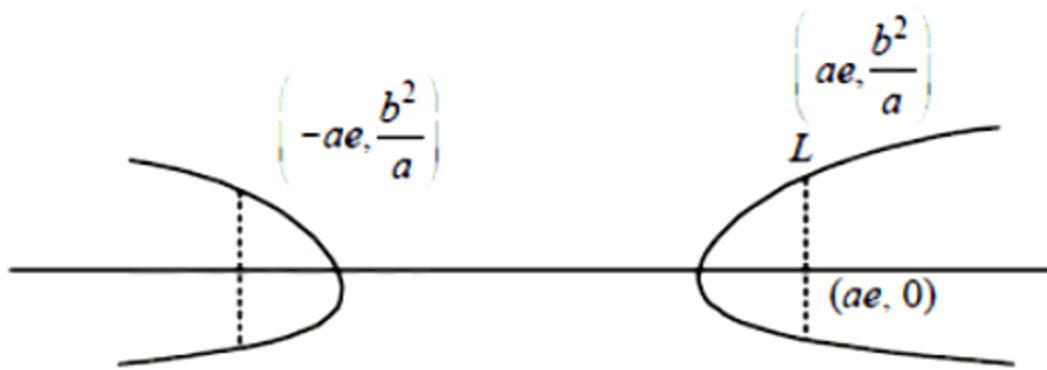

Given $\frac{x^2}{4} - \frac{y^2}{5} = 1$

$\Rightarrow a^2 = 4, b^2 = 5$

$e = \sqrt{\frac{a^2 + b^2}{a^2}} = \sqrt{\frac{4 + 5}{4}} = \frac{3}{2}$

$L = \left(2 \times \frac{3}{2}, \frac{5}{2}\right) = \left(3, \frac{5}{2}\right)$

Equation of tangent at (x_1, y_1) is

$\frac{xx_1}{a^2} - \frac{yy_1}{b^2} = 1$

Here $x_1 = 3, y_1 = \frac{5}{2}$

$\Rightarrow \frac{3x}{4} - \frac{y}{2} = 1 \Rightarrow \frac{x}{4} + \frac{y}{-2} = 1$

x -intercept of the tangent, $OA = \frac{4}{3}$

y -intercept of the tangent, $OB = -2$

$OA^2 - OB^2 = \frac{16}{9} - 4 = -\frac{20}{9}$

Question 426

Let $P(3 \sec \theta, 2 \tan \theta)$ and $Q(3 \sec \phi, 2 \tan \phi)$ where $\theta + \phi = \frac{\pi}{2}$, be two distinct points on the hyperbola $\frac{x^2}{9} - \frac{y^2}{4} = 1$. Then the ordinate of the point of intersection of the normals at P and Q is:
[Online April 11, 2014]

Options:

A. $\frac{11}{3}$

B. $-\frac{11}{3}$

C. $\frac{13}{2}$

D. $-\frac{13}{2}$

Answer: D

Solution:

Solution:

Let the coordinate at point of intersection of normals at P and Q be (h, k)

Since, equation of normals to the hyperbola $\frac{x^2}{a^2} - \frac{y^2}{b^2} = 1$

At point (x_1, y_1) is $\frac{a^2x}{x_1} + \frac{b^2y}{y_1} = a^2 + b^2$ therefore equation of normal to the hyperbola $\frac{x^2}{3^2} - \frac{y^2}{2^2}$

= 1 at point P(3 sec θ , 2 tan θ) is

$$\frac{3^2x}{3 \sec \theta} + \frac{2^2y}{2 \tan \theta} = 3^2 + 2^2$$

$$\Rightarrow 3x \cos \theta + 2y \cot \theta = 3^2 + 2^2 \dots (1)$$

Similarly, Equation of normal to the hyperbola $\frac{x^2}{3^2} - \frac{y^2}{2^2}$

at point Q(3 sec ϕ , 2 tan ϕ) is

$$\frac{3^2x}{3 \sec \phi} + \frac{2^2y}{2 \tan \phi} = 3^2 + 2^2$$

$$\Rightarrow 3x \cos \phi + 2y \cot \phi = 3^2 + 2^2 \dots (2)$$

Given $\theta + \phi = \frac{\pi}{2} \Rightarrow \phi = \frac{\pi}{2} - \theta$ and these passes through (h, k)

\therefore From eq. (2)

$$3x \cos \left(\frac{\pi}{2} - \theta \right) + 2y \cot \left(\frac{\pi}{2} - \theta \right) = 3^2 + 2^2$$

$$\Rightarrow 3h \sin \theta + 2k \tan \theta = 3^2 + 2^2 \dots (3)$$

$$\text{and } 3h \cos \theta + 2k \cot \theta = 3^2 + 2^2 \dots (4)$$

Comparing equation (3) & (4), we get

$$3h \cos \theta + 2k \cot \theta = 3h \sin \theta + 2k \tan \theta$$

$$3h \cos \theta - 3h \sin \theta = 2k \tan \theta - 2k \cot \theta$$

$$3h(\cos \theta - \sin \theta) = 2k(\tan \theta - \cot \theta)$$

$$3h(\cos \theta - \sin \theta) = 2k \frac{(\sin \theta - \cos \theta)(\sin \theta + \cos \theta)}{\sin \theta \cos \theta}$$

$$\text{or, } 3h = \frac{-2k(\sin \theta + \cos \theta)}{\sin \theta \cos \theta}$$

$$\text{Now, putting the value of equation (5) in eq. (3) } \frac{-2k(\sin \theta + \cos \theta) \sin \theta}{\sin \theta \cos \theta} + 2k \tan \theta = 3^2 + 2^2$$

$$\Rightarrow 2k \tan \theta - 2k + 2k \tan \theta = 13$$

$$-2k = 13 \Rightarrow k = \frac{-13}{2}$$

Hence, ordinate of point of intersection of normals at P and Q is $\frac{-13}{2}$

Question427

If a circle of unit radius is divided into two parts by an arc of another circle subtending an angle 60° on the circumference of the first circle, then the radius of the arc is:

[Online April 25, 2013]

Options:

A. $\sqrt{3}$

B. $\frac{1}{2}$

C. 1

D. $\sqrt{2}$

Answer: A

Solution:

Solution:

If a circle of unit radius is divided into two parts, by an arc of another circle subtending an angle of 60° on the circumference of the first circle, then the radius of the arc = $2 \times \sin 60^\circ = 2 \times \frac{\sqrt{3}}{2} = \sqrt{3}$

Question428

The circle passing through (1,-2) and touching the axis of x at (3,0) also passes through the point
[2013]

Options:

A. (-5,2)

B. (2,-5)

C. (5,-2)

D. (-2,5)

Answer: C

Solution:

Solution:

(c) Since circle touches x-axis at (3,0)

∴ The equation of circle be $(x - 3)^2 + (y - 0)^2 + \lambda y = 0$

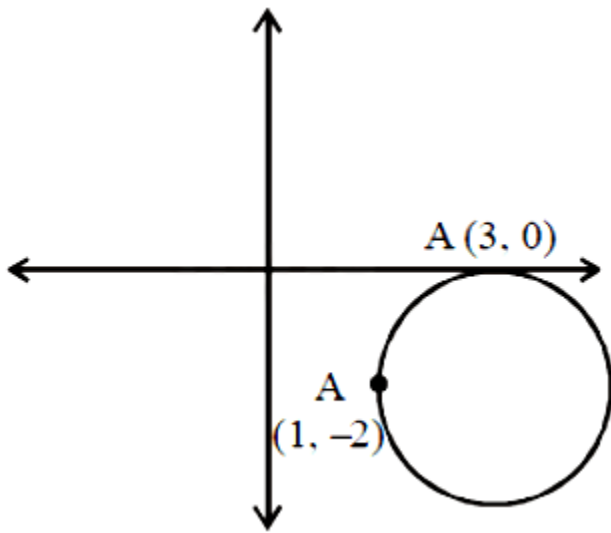

As it passes through (1,-2) ∴ Put $x = 1, y = -2$

$$\Rightarrow (1 - 3)^2 + (-2)^2 + \lambda(-2) = 0$$

$$\Rightarrow \lambda = 4$$

∴ equation of circle is $(x - 3)^2 + y^2 - 8 = 0$

Now, from the options (5,-2) satisfies equation of circle.

Question429

Statement 1: The only circle having radius $\sqrt{10}$ and a diameter along line $2x + y = 5$ is $x^2 + y^2 - 6x + 2y = 0$.

Statement 2: $2x + y = 5$ is a normal to the circle $x^2 + y^2 - 6x + 2y = 0$.
[Online April 25, 2013]

Options:

A. Statement 1 is false; Statement 2 is true.

B. Statement 1 is true; Statement 2 is true, Statement 2 is a correct explanation for Statement 1

C. Statement 1 is true; Statement 2 is false.

D. Statement 1 is true; Statement 2 is true; Statement 2 is not a correct explanation for Statement 1

Answer: A

Solution:

Solution:

Circle : $x^2 + y^2 - 6x + 2y = 0$

Line: $2x + y = 5$

Centre = $(3, -1)$

Now, $2 \times 3 - 1 = 5$, hence centre lies on the given line. Therefore line passes through the centre. The given line is normal to the circle.

Thus statement- 2 is true,

but statement- 1 is not true as there are infinite circle according to the given conditions.

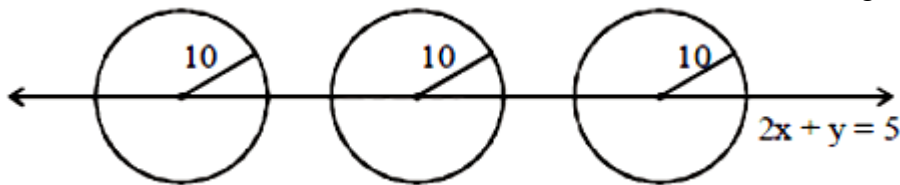

Question430

If the circle $x^2 + y^2 - 6x - 8y + (25 - a^2) = 0$ touches the axis of x, then a equals.

[Online April 23, 2013]

Options:

A. 0

B. ± 4

C. ± 2

D. ± 3

Answer: B

Solution:

Solution:

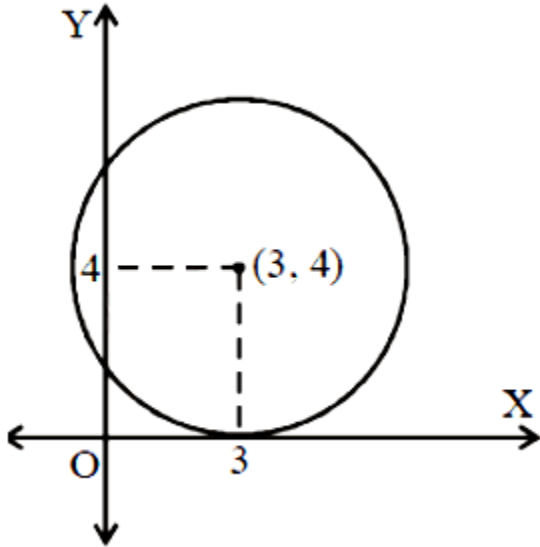

$$x^2 + y^2 - 6x - 8y + (25 - a^2) = 0$$
$$\text{Radius} = 4 = \sqrt{9 + 16 + (25 - a^2)}$$
$$\Rightarrow a = \pm 4$$

Question431

If a circle C passing through (4,0) touches the circle $x^2 + y^2 + 4x - 6y - 12 = 0$ externally at a point (1, -1), then the radius of the circle C is :

[Online April 22, 2013]

Options:

A. 5

B. $2\sqrt{5}$

C. 4

D. $\sqrt{57}$

Answer: A

Solution:

Solution:

Let A be the centre of given circle and B be the centre of circle C.

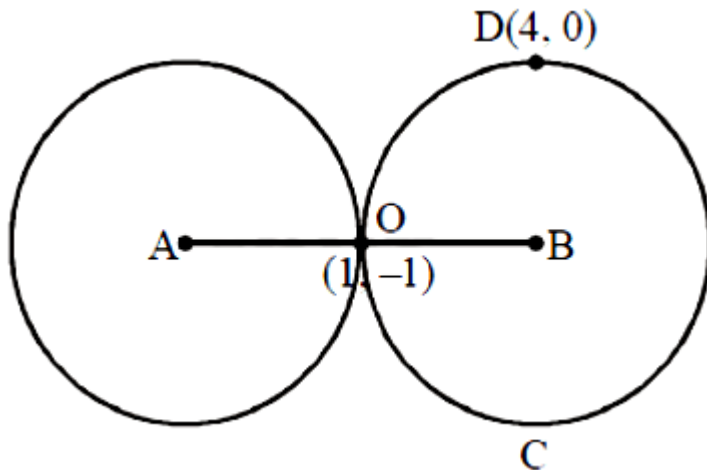

$$x^2 + y^2 + 4x - 6y - 12 = 0$$

$$\therefore A = (-2, 3) \text{ and } B = (g, f)$$

Now, from the figure, we have

$$\frac{-2+g}{2} = 1 \text{ and } \frac{3+f}{2} = -1 \text{ (By mid point formula)}$$

$$\Rightarrow g = 4 \text{ and } f = -5$$

Question432

If two vertices of an equilateral triangle are $A(-a, 0)$ and $B(a, 0)$, $a > 0$, and the third vertex C lies above x -axis then the equation of the circumcircle of $\triangle ABC$ is:

[Online April 22, 2013]

Options:

A. $3x^2 + 3y^2 - 2\sqrt{3}ay = 3a^2$

B. $3x^2 + 3y^2 - 2ay = 3a^2$

C. $x^2 + y^2 - 2ay = a^2$

$$D. x^2 + y^2 - \sqrt{3}ay = a^2$$

Answer: A

Solution:

Solution:

Let $C = (x, y)$

Now, $CA^2 = CB^2 = AB^2$

$$\Rightarrow (x+a)^2 + y^2 = (x-a)^2 + y^2 = (2a)^2$$

$$\Rightarrow x^2 + 2ax + a^2 + y^2 = 4a^2$$

$$\text{and } x^2 - 2ax + a^2 + y^2 = 4a^2$$

From (i) and (ii), $x = 0$ and $y = \pm\sqrt{3}a$

Since point $C(x, y)$ lies above the x -axis and $a > 0$, hence $y = \sqrt{3}a \therefore C = (0, \sqrt{3}a)$

Let the equation of circumcircle be $x^2 + y^2 + 2gx + 2fy + C = 0$

Since points $A(-a, 0)$, $B(a, 0)$ and $C(0, \sqrt{3}a)$ lie on the circle,

therefore $a^2 - 2ga + C = 0$

$$a^2 + 2ga + C = 0 \text{ and } 3a^2 + 2\sqrt{3}af + C = 0 \text{ From (iii), (iv), and (v) } g = 0, c = -a^2, f = -\frac{a}{\sqrt{3}}$$

Hence equation of the circumcircle is $x^2 + y^2 - \frac{2a}{\sqrt{3}}y - a^2 = 0$

$$\Rightarrow x^2 + y^2 - \frac{2\sqrt{3}ay}{3} - a^2 = 0$$

$$\Rightarrow 3x^2 + 3y^2 - 2\sqrt{3}ay = 3a^2$$

Question433

If each of the lines $5x + 8y = 13$ and $4x - y = 3$ contains a diameter of the circle $x^2 + y^2 - 2(a^2 - 7a + 11)x - 2(a^2 - 6a + 6)y + b^3 + 1 = 0$ then [Online April 9, 2013]

Options:

A. $a = 5$ and $b \notin (-1, 1)$

B. $a = 1$ and $b \notin (-1, 1)$

C. $a = 2$ and $b \notin (-\infty, 1)$

D. $a = 5$ and $b \in (-\infty, 1)$

Answer: D

Solution:

Solution:

Point of intersection of two given lines is (1, 1). Since each of the two given lines contains a diameter of the given circle, therefore the point of intersection of the two given lines is the centre of the given circle. Hence centre = (1, 1)

$$\therefore a^2 - 7a + 11 = 1 \Rightarrow a = 2, 5$$

$$\text{and } a^2 - 6a + 6 = 1 \Rightarrow a = 1, 5$$

From both (i) and (ii), $a = 5$

Now on replacing each of $(a^2 - 7a + 11)$ and $(a^2 - 6a + 6)$ by 1, the equation of the given circle is

$$x^2 + y^2 - 2x - 2y + b^3 + 1 = 0$$

$$\Rightarrow (x - 1)^2 + (y - 1)^2 + b^3 = 1$$

$$\Rightarrow b^3 = 1 - [(x - 1)^2 + (y - 1)^2]$$

$$\therefore b \in (-\infty, 1)$$

Question 434

Given : A circle, $2x^2 + 2y^2 = 5$ and a parabola, $y^2 = 4\sqrt{5}x$.

Statement-1 : An equation of a common tangent to these curves is

$$y = x + \sqrt{5}.$$

Statement-2 : If the line, $y = mx + \frac{\sqrt{5}}{m}$ ($m \neq 0$) is their common tangent,

then m satisfies $m^4 - 3m^2 + 2 = 0$.

[2013]

Options:

A. Statement- 1 is true; Statement- 2 is true; Statement-2 is a correct explanation for Statement- 1 .

B. Statement-1 is true; Statement-2 is true; Statement-2 is not a correct explanation for Statement-1.

C. Statement-1 is true; Statement-2 is false.

D. Statement-1 is false; Statement-2 is true.

Answer: B

Solution:

Solution:

Let common tangent be

$$y = mx + \frac{\sqrt{5}}{m}$$

Since, perpendicular distance from centre of the circle to the common tangent is equal to radius of the circle,

$$\frac{\frac{\sqrt{5}}{m}}{\sqrt{1+m^2}} = \sqrt{\frac{5}{2}}$$

On squaring both the side, we get

$$m^2(1+m^2) = 2$$

$$\Rightarrow m^4 + m^2 - 2 = 0$$

$$\Rightarrow (m^2 + 2)(m^2 - 1) = 0$$

$$\Rightarrow m = \pm 1 \quad (\because m^2 \neq -2)$$

$y = \pm(x + \sqrt{5})$, both statements are correct as $m = \pm 1$ satisfies the given equation of statement- 2 .

Question435

The point of intersection of the normals to the parabola $y^2 = 4x$ at the ends of its latus rectum is :
[Online April 23, 2013]

Options:

A. (0,2)

B. (3,0)

C. (0,3)

D. (2,0)

Answer: B

Solution:

Solution:

We know that point of intersection of the normal to the parabola $y^2 = 4ax$ at the ends of its latus rectum is $(3a, 0)$

Hence required point of intersection = $(3, 0)$

Question436

Statement-1: The line $x - 2y = 2$ meets the parabola, $y^2 + 2x = 0$ only at the point $(-2,-2)$.

Statement-2: The line $y = mx - \frac{1}{2m}$ ($m \neq 0$) is tangent to the parabola, $y^2 = -2x$ at the point $\left(-\frac{1}{2m^2}, -\frac{1}{m}\right)$.

[Online April 22, 2013]

Options:

- A. Statement- 1 is true; Statement- 2 is false.
- B. Statement- 1 is true; Statement- 2 is true; Statement-2 is a correct explanation for statement- 1 .
- C. Statement- 1 is false; Statement- 2 is true.
- D. Statement- 1 a true; Statement- 2 is true; Statement- 2 is not a correct explanation for statement-1.

Answer: B

Solution:

Solution:

Both statements are true and statement- 2 is the correct explanation of statement-1

\therefore The straight line $y = mx + \frac{a}{m}$ is always a tangent to the parabola $y^2 = 4ax$ for any value of m .

The co-ordinates of point of contact $\left(\frac{a}{m^2}, \frac{2a}{m}\right)$

Now, required radius = $OB = \sqrt{9 + 16} = \sqrt{25} = 5$

Question437

The equation of the circle passing through the foci of the ellipse

$$\frac{x^2}{16} + \frac{y^2}{9} = 1, \text{ and having centre at } (0,3) \text{ is}$$

[2013]

Options:

A. $x^2 + y^2 - 6y - 7 = 0$

B. $x^2 + y^2 - 6y + 7 = 0$

C. $x^2 + y^2 - 6y - 5 = 0$

D. $x^2 + y^2 - 6y + 5 = 0$

Answer: A

Solution:

Solution:

From the given equation of ellipse, we have

$$a = 4, b = 3, e = \sqrt{1 - \frac{9}{16}}$$

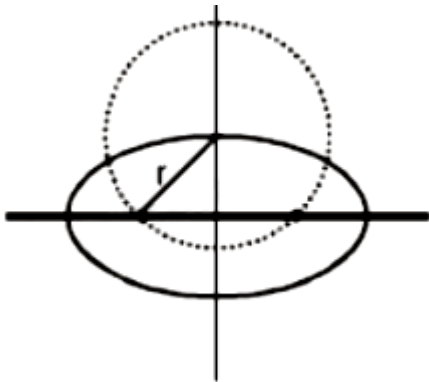

$$\Rightarrow e = \frac{\sqrt{7}}{4}$$

Now, radius of this circle $= a^2 = 16$

$$\Rightarrow \text{Focii} = (\pm\sqrt{7}, 0)$$

Now equation of circle is

$$(x - 0)^2 + (y - 3)^2 = 16$$

$$x^2 + y^2 - 6y - 7 = 0$$

Question438

A point on the ellipse, $4x^2 + 9y^2 = 36$, where the normal is parallel to the line, $4x - 2y - 5 = 0$, is :

[Online April 25, 2013]

Options:

A. $\left(\frac{9}{5}, \frac{8}{5}\right)$

B. $\left(\frac{8}{5}, -\frac{9}{5}\right)$

C. $\left(-\frac{9}{5}, \frac{8}{5}\right)$

D. $\left(\frac{8}{5}, \frac{9}{5}\right)$

Answer: C

Solution:

Solution:

Given ellipse is $4x^2 + 9y^2 = 36$

$$\Rightarrow \frac{x^2}{9} + \frac{y^2}{4} = 1$$

Normal at the point is parallel to the line

$$4x - 2y - 5 = 0$$

Slope of normal = 2

$$\text{Slope of tangent} = \frac{-1}{2}$$

$$\text{Point of contact to ellipse } \frac{x^2}{a^2} + \frac{y^2}{b^2} = 1$$

$$\text{and line is } \left(\frac{a^2 m}{\sqrt{a^2 m^2 + b^2}}, \frac{b}{\sqrt{a^2 m^2 + b^2}} \right)$$

$$\text{Now, } a^2 = 9, b^2 = 4$$

$$\text{Point} = \left(\frac{-9}{5}, \frac{8}{5} \right)$$

Question439

Let the equations of two ellipses be

$$E_1 : \frac{x^2}{3} + \frac{y^2}{2} = 1 \text{ and } E_2 : \frac{x^2}{16} + \frac{y^2}{b^2} = 1$$

If the product of their eccentricities is $\frac{1}{2}$, then the length of the minor axis of ellipse E_2 is :

:[Online April 22, 2013]

Options:

A. 8

B. 9

C. 4

D. 2

Answer: C

Solution:

Solution:

Given equations of ellipses

$$E_1 : \frac{x^2}{3} + \frac{y^2}{2} = 1$$

$$\Rightarrow e_1 = \sqrt{1 - \frac{2}{3}} = \frac{1}{\sqrt{3}}$$

$$\text{and } E_2 : \frac{x^2}{16} + \frac{y^2}{b^2} = 1$$

$$\Rightarrow e_2 = \sqrt{\frac{1-b^2}{16}} = \sqrt{\frac{16-b^2}{4}}$$

$$\text{Also, given } e_1 \times e_2 = \frac{1}{2}$$

$$\Rightarrow \frac{1}{\sqrt{3}} \times \sqrt{\frac{16-b^2}{4}} = \frac{1}{2} \Rightarrow 16-b^2 = 12$$

$$\Rightarrow b^2 = 4$$

\therefore Length of minor axis of

$$E_2 = 2b = 2 \times 2 = 4$$

Question440

Equation of the line passing through the points of intersection of the parabola $x^2 = 8y$ and the ellipse $\frac{x^2}{3} + y^2 = 1$ is:

[Online April 9, 2013]

Options:

A. $y - 3 = 0$

B. $y + 3 = 0$

C. $3y + 1 = 0$

D. $3y - 1 = 0$

Answer: D

Solution:

Solution:

$$x^2 = 8y \dots (i)$$

$$\frac{x^2}{3} + y^2 = 1 \dots (ii)$$

From (i) and (ii),

$$\frac{8y}{3} + y^2 = 1 \Rightarrow y = -3, \frac{1}{3}$$

When $y = -3$, then $x^2 = -24$, which is not possible.

$$\text{When } y = \frac{1}{3}, \text{ then } x = \pm \frac{2\sqrt{6}}{3}$$

Point of intersection are

$$\left(\frac{2\sqrt{6}}{3}, \frac{1}{3} \right) \text{ and } \left(-\frac{2\sqrt{6}}{3}, \frac{1}{3} \right)$$

Required equation of the line,

$$y - \frac{1}{3} = 0 \Rightarrow 3y - 1 = 0$$

Question441

A common tangent to the conics $x^2 = 6y$ and $2x^2 - 4y^2 = 9$ is:

[Online April 25, 2013]

Options:

A. $x - y = \frac{3}{2}$

B. $x + y = 1$

C. $x + y = \frac{9}{2}$

D. $x - y = 1$

Answer: A

Solution:

Solution:

$$x^2 - 6y = 0 \dots (i)$$

$$2x^2 - 4y^2 = 9 \dots (ii)$$

Consider the line,

$$x - y = \frac{3}{2} \dots (iii)$$

On solving (i) and (iii), we get only

$$x = 3, y = \frac{3}{2}$$

Hence $(3, \frac{3}{2})$ is the point of contact of conic (i), and line(iii)

On solving (ii) and (iii), we get only $x = 3, y = \frac{3}{2}$

Hence $(3, \frac{3}{2})$ is also the point of contact of conic (ii) and line(iii).

Hence line (iii) is the common tangent to both the given conics.

Question442

A tangent to the hyperbola $\frac{x^2}{4} - \frac{y^2}{2} = 1$ meets x -axis at P and y -axis at

Q. Lines PR and QR are drawn such that OPRQ is a rectangle(where O is the origin). Then R lies on:

[Online April 23, 2013]

Options:

A. $\frac{4}{x^2} + \frac{2}{y^2} = 1$

B. $\frac{2}{x^2} - \frac{4}{y^2} = 1$

C. $\frac{2}{x^2} + \frac{4}{y^2} = 1$

D. $\frac{4}{x^2} - \frac{2}{y^2} = 1$

Answer: D

Solution:

Solution:

Equation of the tangent at the point $^{\circ}\theta$ ' is

$$\frac{x \sec \theta}{a} - \frac{y \tan \theta}{b} = 1$$

$\Rightarrow P = (a \cos \theta, 0)$ and $Q = (0, -b \cot \theta)$

Let R be $(h, k) \Rightarrow h = a \cos \theta, k = -b \cot \theta$

$$\Rightarrow \frac{k}{h} = \frac{-b}{a \sin \theta} \Rightarrow \sin \theta = \frac{-bh}{ak} \text{ and } \cos \theta = \frac{h}{a}$$

By squaring and adding,

$$\frac{b^2 h^2}{a^2 k^2} + \frac{h^2}{a^2} = 1$$

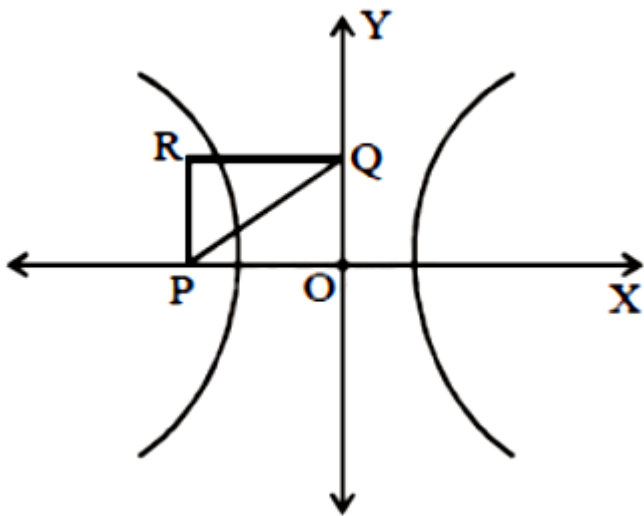

$$\Rightarrow \frac{b^2}{k^2} + 1 = \frac{a^2}{h^2} \Rightarrow \frac{a^2}{h^2} - \frac{b^2}{k^2} = 1$$

Now, given eqⁿ of hyperbola is $\frac{x^2}{4} - \frac{y^2}{2} = 1$

$$\Rightarrow a^2 = 4, b^2 = 2$$

$$\therefore R \text{ lies on } \frac{a^2}{x^2} - \frac{b^2}{y^2} = 1 \text{ i.e., } \frac{4}{x^2} - \frac{2}{y^2} = 1$$

Question443

The length of the diameter of the circle which touches the x -axis at the point (1,0) and passes through the point (2,3) is:
[2012]

Options:

A. $\frac{10}{3}$

B. $\frac{3}{5}$

C. $\frac{6}{5}$

D. $\frac{5}{3}$

Answer: A

Solution:

Solution:

Since, circle touches , the x-axis at (1, 0). So, let centreof the circle be (1, h)

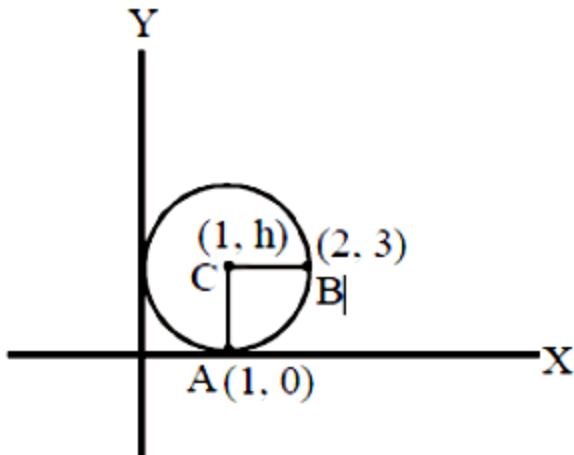

Given that circle passes through the point B(2, 3)

$$\therefore CA = CB \text{ (radius)} \Rightarrow CA^2 = CB^2$$

$$\Rightarrow (1-1)^2 + (h-0)^2 = (1-2)^2 + (h-3)^2$$

$$\Rightarrow h^2 = 1 + h^2 + 9 - 6h$$

$$\Rightarrow h = \frac{10}{6} = \frac{5}{3}$$

$$\therefore \text{Length of the diameter} = \frac{10}{3}$$

Question444

The number of common tangents of the circles given by

$$x^2 + y^2 - 8x - 2y + 1 = 0 \text{ and } x^2 + y^2 + 6x + 8y = 0 \text{ is}$$

[Online May 26, 2012]

Options:

A. one

B. four

C. two

D. three

Answer: C

Solution:

Solution:

(c) Given circles are

$$x^2 + y^2 - 8x - 2y + 1 = 0$$

$$\text{and } x^2 + y^2 + 6x + 8y = 0$$

Their centres and radius are

$$C_1(4, 1), r_1 = \sqrt{16} = 4$$

$$C_2(-3, -4), r_2 = \sqrt{25} = 5$$

$$\text{Now, } C_1C_2 = \sqrt{49 + 25} = \sqrt{74}$$

$$r_1 - r_2 = -1, r_1 + r_2 = 9$$

$$\text{Since, } r_1 - r_2 < C_1C_2 < r_1 + r_2$$

$$\therefore \text{Number of common tangents} = 2$$

Question445

If the line $y = mx + 1$ meets the circle $x^2 + y^2 + 3x = 0$ in two points equidistant from and on opposite sides of x-axis, then

[Online May 19, 2012]

Options:

A. $3m + 2 = 0$

B. $3m - 2 = 0$

C. $2m + 3 = 0$

D. $2m - 3 = 0$

Answer: B

Solution:

Solution:

Circle : $x^2 + y^2 + 3x = 0$

Centre, $B = \left(-\frac{3}{2}, 0\right)$

Radius = $\frac{3}{2}$ units.

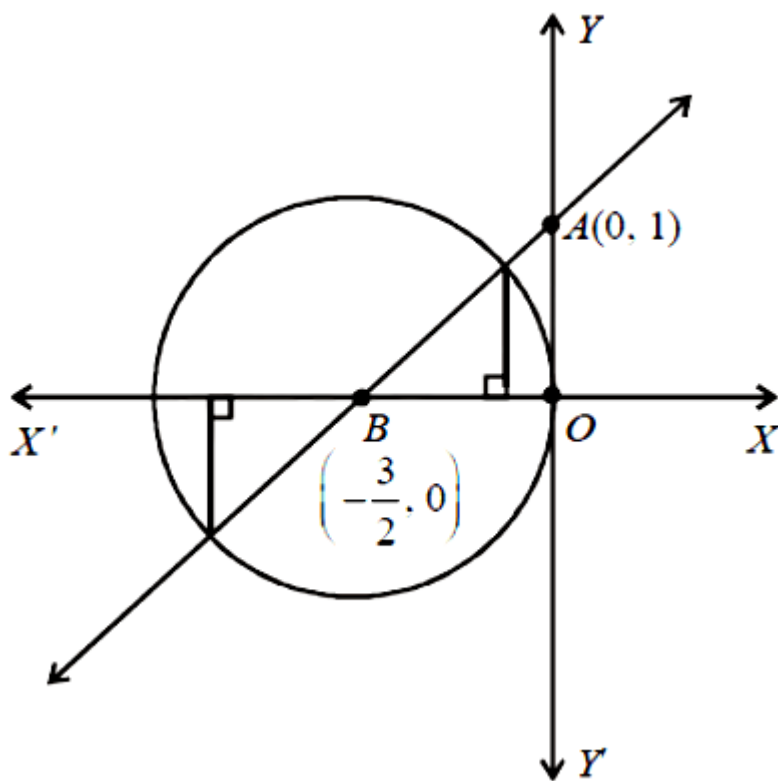

Line : $y = mx + 1$

y-intercept of the line = 1

$\therefore A = (0, 1)$

Slope of line, $m = \tan \theta = \frac{OA}{OB}$

$$\Rightarrow m = \frac{1}{\frac{3}{2}} = \frac{2}{3}$$

$$\Rightarrow 3m - 2 = 0$$

Question446

If three distinct points A, B, C are given in the 2 -dimensional coordinate plane such that the ratio of the distance of each one of them from the point (1,0) to the distance from (-1,0) is equal to $\frac{1}{2}$, then the circumcentre of the triangle ABC is at the point
[Online May 19, 2012]

Options:

A. $\left(\frac{5}{3}, 0\right)$

B. (0,0)

C. $\left(\frac{1}{3}, 0\right)$

D. (3,0)

Answer: A

Solution:

Solution:

Let P(1, 0) and Q(-1, 0), A(x, y)

$$\text{Given: } \frac{AP}{AQ} = \frac{BP}{BQ} = \frac{CP}{CQ} = \frac{1}{2}$$

$$\Rightarrow 2AP = AQ$$

$$\Rightarrow 4(AP)^2 = AQ^2$$

$$\Rightarrow 4[(x-1)^2 + y^2] = (x+1)^2 + y^2$$

$$\Rightarrow 4(x^2 + 1 - 2x) + 4y^2 = x^2 + 1 + 2x + y^2$$

$$\Rightarrow 3x^2 + 3y^2 - 8x - 2x + 4 - 1 = 0$$

$$\Rightarrow 3x^2 + 3y^2 - 10x + 3 = 0$$

$$\Rightarrow x^2 + y^2 - \frac{10}{3}x + 1 = 0$$

∴ A lies on the circle given by (1) . As B and C also follow the same condition.

∴ Centre of circumcircle of ΔABC = centre of circle given by (1) = $\left(\frac{5}{3}, 0\right)$

Question447

The equation of the circle passing through the point (1,2) and through the points of intersection of $x^2 + y^2 - 4x - 6y - 21 = 0$ and $3x + 4y + 5 = 0$ is given by

[Online May 7, 2012]

Options:

A. $x^2 + y^2 + 2x + 2y + 11 = 0$

B. $x^2 + y^2 - 2x + 2y - 7 = 0$

C. $x^2 + y^2 + 2x - 2y - 3 = 0$

D. $x^2 + y^2 + 2x + 2y - 11 = 0$

Answer: D

Solution:

Solution:

Point (1,2) lies on the circle $x^2 + y^2 + 2x + 2y - 11 = 0$, because coordinates of point (1,2) satisfy the equation

$$x^2 + y^2 + 2x + 2y - 11 = 0$$

Now, $x^2 + y^2 - 4x - 6y - 21 = 0$ (i)

$$x^2 + y^2 + 2x + 2y - 11 = 0$$

$$3x + 4y + 5 = 0$$

From (i) and (iii),

$$x^2 + \left(-\frac{3x+5}{4}\right)^2 - 4x - 6\left(-\frac{3x+5}{4}\right) - 21 = 0$$

$$\Rightarrow 16x^2 + 9x^2 + 30x + 25 - 64x + 72x + 120 - 336 = 0$$

$$\Rightarrow 25x^2 + 38x - 191 = 0 \text{ From (ii) and (iii), } x^2 + \left(-\frac{3x+5}{4}\right)^2 + 2x + 2\left(-\frac{3x+5}{4}\right) - 11 = 0$$

$$\Rightarrow 16x^2 + 9x^2 + 30x + 25 + 32x - 24x - 40 - 176 = 0$$

$$\Rightarrow 25x^2 + 38x - 191 = 0 \text{ ... (v)}$$

Thus we get the same equation

from (ii) and (iii) as we get from equation (i) and (iii).

Hence the point of intersections of (ii) and (iii) will be same as the point of intersections of (i) and (iii). Therefore the circle (ii) passing through the point of intersection of circle(i) and point (1,2) also as shown in the figure.

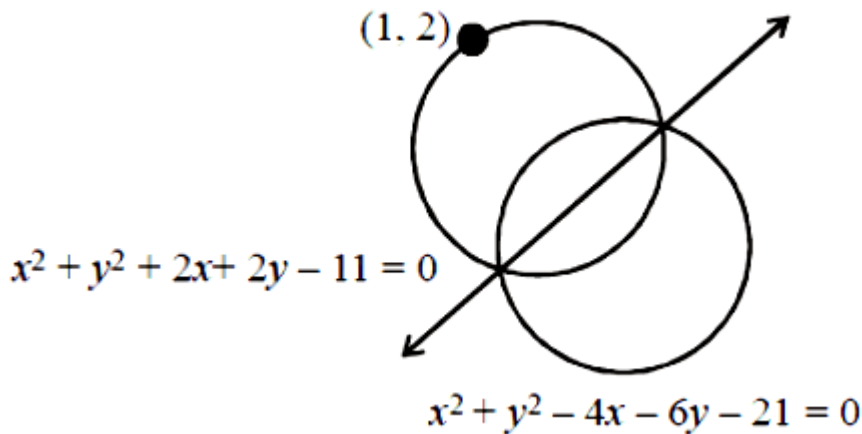

Hence equation(ii) i.e.

$x^2 + y^2 + 2x + 2y - 11 = 0$ is the equation of required circle.

Question448

The normal at $\left(2, \frac{3}{2}\right)$ to the ellipse, $\frac{x^2}{16} + \frac{y^2}{3} = 1$ touches a parabola, whose equation is
[Online May 26, 2012]

Options:

A. $y^2 = -104x$

B. $y^2 = 14x$

C. $y^2 = 26x$

D. $y^2 = -14x$

Answer: A

Solution:

Ellipse is $\frac{x^2}{16} + \frac{y^2}{3} = 1$

Now, equation of normal at $(2, 3/2)$ is

$$\frac{16x}{2} - \frac{3y}{3/2} = 16 - 3$$

$$\Rightarrow 8x - 2y = 13$$

$$\Rightarrow y = 4x - \frac{13}{2}$$

Let $y = 4x - \frac{13}{2}$ touches a parabola

$$y^2 = 4ax$$

We know, a straight line $y = mx + c$ touches a parabola $y^2 = 4ax$

if $a - mc = 0$

$$\therefore a - (4)\left(-\frac{13}{2}\right) = 0 \Rightarrow a = -26$$

Hence, required equation of parabola is $y^2 = 4(-26)x = -104x$

Question449

The chord PQ of the parabola $y^2 = x$, where one end P of the chord is at point $(4,-2)$, is perpendicular to the axis of the parabola. Then the slope of the normal at Q is
[Online May 26, 2012]

Options:

A. -4

B. $-\frac{1}{4}$

C. 4

D. $\frac{1}{4}$

Answer: A

Solution:

Point P is (4,-2) and $PQ \perp x$ -axis So, $Q = (4, 2)$

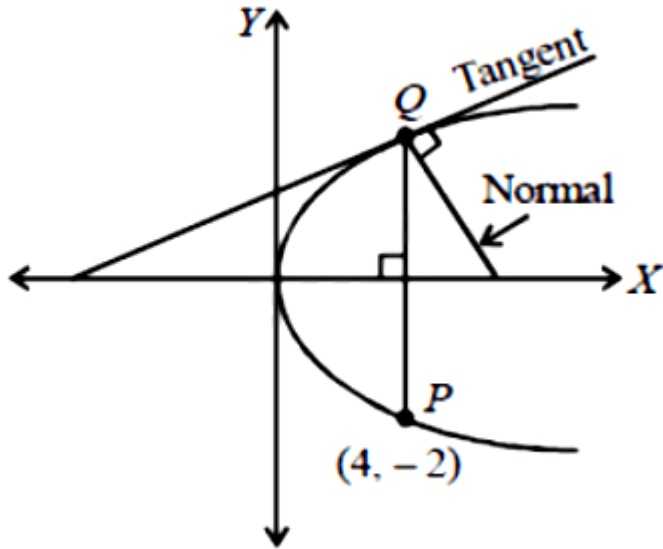

Equation of tangent at (4,2) is

$$yy_1 = \frac{1}{2}(x + x_1)$$

$$\Rightarrow 2y = \frac{1}{2}(x + 2) \Rightarrow 4y = x + 2$$

$$\Rightarrow y = \frac{x}{4} + \frac{1}{2}$$

So, slope of tangent = $\frac{1}{4}$

\therefore Slope of normal = -4

Question450

Statement 1: $y = mx - \frac{1}{m}$ is always a tangent to the parabola, $y^2 = -4x$ for all non-zero values of m .

Statement 2: Every tangent to the parabola, $y^2 = -4x$ will meet its axis at a point whose abscissa is non-negative.

[Online May 7, 2012]

Options:

A. Statement 1 is true, Statement 2 is true; Statement 2 is a correct explanation of Statement 1 .

B. Statement 1 is false, Statement 2 is true.

C. Statement 1 is true, Statement 2 is false.

D. Statement 1 is true, Statement 2 is true, Statement 2 is not a correct explanation of Statement 1 .

Answer: D

Solution:

Solution:

Both the given statements are true.

Statement -2 is not the correct explanation for statement -1

Question451

If P_1 and P_2 are two points on the ellipse $\frac{x^2}{4} + y^2 = 1$ at which the tangents are parallel to the chord joining the points $(0,1)$ and $(2, 0)$, then the distance between P_1 and P_2 is

[Online May 12, 2012]

Options:

A. $2\sqrt{2}$

B. $\sqrt{5}$

C. $2\sqrt{3}$

D. $\sqrt{10}$

Answer: D

Solution:

Solution:

Any tangent on an ellipse $\frac{x^2}{a^2} + \frac{y^2}{b^2} = 1$ is given by

$$y = mx \pm \sqrt{a^2 m^2 + b^2}$$

Here $a = 2, b = 1$

$$m = \frac{1-0}{0-2} = -\frac{1}{2}$$

$$c = \sqrt{4\left(-\frac{1}{2}\right)^2 + 1^2} = \sqrt{2}$$

$$\text{So, } y = -\frac{1}{2}x \pm \sqrt{2}$$

$$\text{For ellipse : } \frac{x^2}{4} + \frac{y^2}{1} = 1$$

$$\text{We put } y = -\frac{1}{2}x + \sqrt{2}$$

$$\therefore \frac{x^2}{4} + \left(-\frac{x}{2} + \sqrt{2}\right)^2 = 1$$

$$\frac{x^2}{4} + \left(\frac{x^2}{4} - 2\left(\frac{x}{2}\right)\sqrt{2} + 2\right) = 1$$

$$\Rightarrow x^2 + 2\sqrt{2}x + 2 = 0$$

$$\text{or } x^2 - 2\sqrt{2}x + 2 = 0$$

$$\Rightarrow x = \sqrt{2} \text{ or } -\sqrt{2}$$

$$\text{If } x = \sqrt{2}, y = \frac{1}{\sqrt{2}} \text{ and } x = -\sqrt{2}, y = -\frac{1}{\sqrt{2}}$$

$$\therefore \text{Points are } \left(\sqrt{2}, \frac{1}{\sqrt{2}}\right), \left(-\sqrt{2}, -\frac{1}{\sqrt{2}}\right)$$

$$\therefore RP_2 = \sqrt{\left\{\frac{1}{\sqrt{2}} - \left(-\frac{1}{\sqrt{2}}\right)\right\}^2 + \{\sqrt{2} - (-\sqrt{2})\}^2}$$

$$= \sqrt{\left(\frac{2}{\sqrt{2}}\right)^2 + (2\sqrt{2})^2} = \sqrt{2+8} = \sqrt{10}$$

Question452

If the foci of the ellipse $\frac{x^2}{16} + \frac{y^2}{b^2} = 1$ coincide with the foci of the

hyperbola $\frac{x^2}{144} - \frac{y^2}{81} = \frac{1}{25}$, then b^2 is equal to

[Online May 19, 2012]

Options:

A. 8

B. 10

C. 7

D. 9

Answer: C

Solution:

Solution:

Given equation of ellipse is

$$\frac{x^2}{16} + \frac{y^2}{b^2} = 1$$

$$\text{eccentricity} = e = \sqrt{1 - \frac{b^2}{16}}$$

$$\text{foci: } \pm ae = \pm 4 \sqrt{1 - \frac{b^2}{16}}$$

Equation of hyperbola is $\frac{x^2}{144} - \frac{y^2}{81} = \frac{1}{25}$

$$\Rightarrow \frac{x^2}{\frac{144}{25}} - \frac{y^2}{\frac{81}{25}} = 1$$

$$\text{eccentricity} = e = \sqrt{1 + \frac{81}{25} \times \frac{25}{144}} = \sqrt{1 + \frac{81}{144}}$$

$$= \sqrt{\frac{225}{144}} = \frac{15}{12}$$

$$\text{foci: } \pm ae = \pm \frac{12}{5} \times \frac{15}{12} = \pm 3$$

Since, foci of ellipse and hyperbola coincide

$$\therefore \pm 4 \sqrt{1 - \frac{b^2}{16}} = \pm 3 \Rightarrow b^2 = 7$$

$$\frac{K^2}{9} - \frac{4}{4} = 1 (\because b = \pm 2)$$

$$\Rightarrow K^2 = 18$$

Question453

If the eccentricity of a hyperbola $\frac{x^2}{9} - \frac{y^2}{b^2} = 1$, which passes through

$(k, 2)$, is $\frac{\sqrt{13}}{3}$, then the value of k^2 is

[Online May 7, 2012]

Options:

A. 18

B. 8

C. 1

D. 2

Answer: A

Solution:

Solution:

Given hyperbola is

$$\frac{x^2}{9} - \frac{y^2}{b^2} = 1$$

Since this passes through $(K, 2)$, therefore

$$\frac{K^2}{9} - \frac{4}{b^2} = 1 \dots (1)$$

$$\text{Also, given } e = \sqrt{1 + \frac{b^2}{a^2}} = \frac{\sqrt{13}}{3}$$

$$\Rightarrow \sqrt{1 + \frac{b^2}{9}} = \frac{\sqrt{13}}{3} \Rightarrow 9 + b^2 = 13$$

$$\Rightarrow b = \pm 2$$

Now, from eqⁿ(1), we have

$$\frac{K^2}{9} - \frac{4}{4} = 1 \quad (\because b = \pm 2)$$

$$\Rightarrow K^2 = 18$$

Question454

The equation of the circle passing through the point $(1,0)$ and $(0,1)$ and having the smallest radius is -

[2011 RS]

Options:

A. $x^2 + y^2 - 2x - 2y + 1 = 0$

B. $x^2 + y^2 - x - y = 0$

C. $x^2 + y^2 + 2x + 2y - 7 = 0$

D. $x^2 + y^2 + x + y - 2 = 0$

Answer: B

Solution:

Solution:

Given circle whose diametric end points are (1,0) and (0,1) will be of smallest radius. Equation of this smallest circle is

$$(x-1)(x-0) + (y-0)(y-1) = 0$$

$$\Rightarrow x^2 + y^2 - x - y = 0$$

Question455

The two circles $x^2 + y^2 = ax$ and $x^2 + y^2 = c^2$ ($c > 0$) touch each other if [2011]

Options:

A. $|a| = c$

B. $a = 2c$

C. $|a| = 2c$

D. $2|a| = c$

Answer: A

Solution:

Solution:

If the two circles touch each other and centre (0,0) of $x^2 + y^2 = c^2$ is lies on circle $x^2 + y^2 = ax$ then they

must touch each other internally. So, $\frac{|a|}{2} = c - \frac{|a|}{2} \Rightarrow |a| = c$

Question456

The shortest distance between line $y - x = 1$ and curve $x = y^2$ is [2011]

Options:

A. $\frac{3\sqrt{2}}{8}$

B. $\frac{8}{3\sqrt{2}}$

C. $\frac{4}{\sqrt{3}}$

D. $\frac{\sqrt{3}}{4}$

Answer: A

Solution:

Solution:

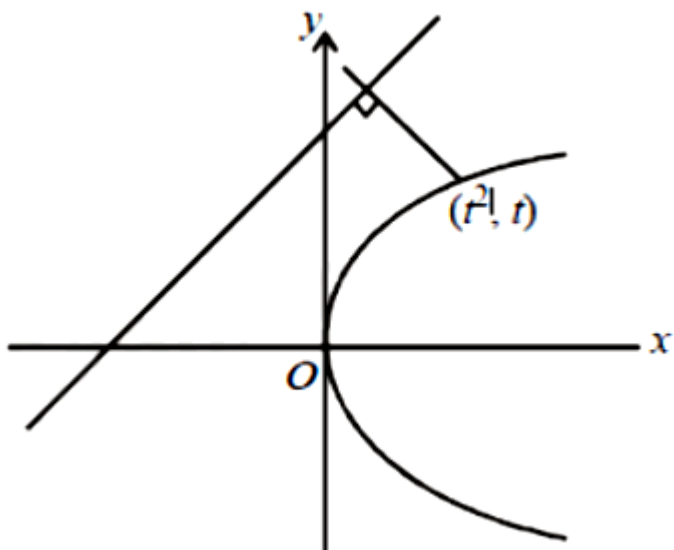

Let (t^2, t) be point on parabola from that line have shortest distance.

$$\text{Distance} = \left| \frac{t^2 - t + 1}{\sqrt{2}} \right|$$

$$= \frac{1}{\sqrt{2}} \left[\left(t - \frac{1}{2} \right)^2 + \frac{3}{4} \right]$$

Distance is minimum when $t - \frac{1}{2} = 0$

$$= \frac{1}{\sqrt{2}} \left[0 + \frac{3}{4} \right] = \frac{3\sqrt{2}}{8}$$

Question457

Equation of the ellipse whose axes are the axes of coordinates and which passes through the point $(-3,1)$ and has eccentricity $\sqrt{\frac{2}{5}}$ is

[2011]

Options:

A. $5x^2 + 3y^2 - 48 = 0$

B. $3x^2 + 5y^2 - 15 = 0$

C. $5x^2 + 3y^2 - 32 = 0$

D. $3x^2 + 5y^2 - 32 = 0$

Answer: D

Solution:

Solution:

Let the equation of ellipse be $\frac{x^2}{a^2} + \frac{y^2}{b^2} = 1$

Given it passes through $(-3,1)$ so

$$\frac{9}{a^2} + \frac{1}{b^2} = 1 \dots\dots (i)$$

Also, we know that

$$b^2 = a^2(1 - e^2) = a^2(1 - 2/5)$$

$$\Rightarrow 5b^2 = 3a^2 \dots\dots (ii)$$

Solving (i) and (ii) we get $a^2 = \frac{32}{3}, b^2 = \frac{32}{5}$

So, the equation of the ellipse is

$$3x^2 + 5y^2 = 32$$

Question458

The equation of the hyperbola whose foci are $(-2,0)$ and $(2,0)$ and eccentricity is 2 is given by :

[2011RS]

Options:

A. $x^2 - 3y^2 = 3$

B. $3x^2 - y^2 = 3$

C. $-x^2 + 3y^2 = 3$

D. $-3x^2 + y^2 = 3$

Answer: B

Solution:

Solution:

Given that $ae = 2$ and $e = 2$

$$\therefore a = 1$$

We know, $b^2 = a^2(e^2 - 1)$

$$b^2 = 1(4 - 1)$$

$$b^2 = 3$$

\therefore Equation of hyperbola, $\frac{x^2}{a^2} - \frac{y^2}{b^2} = 1$

$$\Rightarrow \frac{x^2}{1} - \frac{y^2}{3} = 1$$

$$3x^2 - y^2 = 3$$

Question459

The circle $x^2 + y^2 = 4x + 8y + 5$ intersects the line $3x - 4y = m$ at two distinct points if [2010]

Options:

A. $-35 < m < 15$

B. $15 < m < 65$

C. $35 < m < 85$

D. $-85 < m < -35$

Answer: A

Solution:

Solution:

Given equation of circle is

$$x^2 + y^2 - 4x - 8y - 5 = 0$$

Centre = (2, 4), Radius = $\sqrt{4 + 16 + 5} = 5$

Given circle is intersecting the line

$3x - 4y = m$, at two distinct points.

$$\Rightarrow \text{length of perpendicular from centre to the line} < \text{radius} \Rightarrow \frac{|6 - 16 - m|}{5} < 5 \Rightarrow |10 + m| < 25$$

$$\Rightarrow -25 < m + 10 < 25 \Rightarrow -35 < m < 15$$

Question460

If two tangents drawn from a point P to the parabola $y^2 = 4x$ are at right angles, then the locus of P is [2010]

Options:

A. $2x + 1 = 0$

B. $x = -1$

C. $2x - 1 = 0$

D. $x = 1$

Answer: B

Solution:

Solution:

We know that the locus of perpendicular tangents is directrix i.e., $x = -a$; $x = -1$

Question461

If P and Q are the points of intersection of the circles

$x^2 + y^2 + 3x + 7y + 2p - 5 = 0$ and $x^2 + y^2 + 2x + 2y - p^2 = 0$ then there is a circle passing through P, Q and (1,1) for:
[2009]

Options:

- A. all except one value of p
- B. all except two values of p
- C. exactly one value of p
- D. all values of p

Answer: A

Solution:

Solution:

The given circles are

$$S_1 \equiv x^2 + y^2 + 3x + 7y + 2p - 5 = 0 \dots (1)$$

$$S_2 \equiv x^2 + y^2 + 2x + 2y - p^2 = 0$$

∴ Equation of common chord PQ is

$$S_1 - S_2 = 0 \quad [\text{From (i) and(ii) }]$$

$$\Rightarrow L \equiv x + 5y + p^2 + 2p - 5 = 0$$

⇒ Equation of circle passing through P and Q is $S_1 + \lambda L = 0$

$$\Rightarrow (x^2 + y^2 + 3x + 7y + 2p - 5) + \lambda(x + 5y + p^2 + 2p - 5) = 0$$

Given that it passes through (1, 1), therefore

$$(7 + 2p) + \lambda(2p + p^2 + 1) = 0$$

$$\Rightarrow \lambda = - \frac{2p + 7}{(p + 1)^2}$$

which does not exist for $p = -1$

Question462

Three distinct points A, B and C are given in the 2 -dimensional coordinates plane such that the ratio of the distance of any one of them from the point (1,0) to the distance from the point (-1,0) is equal to $\frac{1}{3}$.

**Then the circumcentre of the triangle ABC is at the point:
[2009]**

Options:

A. $\left(\frac{5}{4}, 0\right)$

B. $\left(\frac{5}{2}, 0\right)$

C. $\left(\frac{5}{3}, 0\right)$

D. (0,0)

Answer: A

Solution:

Solution:

Given that $P(1, 0)$, $Q(-1, 0)$ and $\frac{AP}{AQ} = \frac{BP}{BQ} = \frac{CP}{CQ} = \frac{1}{3}$

$$\Rightarrow 3AP = AQ$$

Let $A = (x, y)$ then $3AP = AQ \Rightarrow 9AP^2 = AQ^2$

$$\Rightarrow 9(x-1)^2 + 9y^2 = (x+1)^2 + y^2$$

$$\Rightarrow 9x^2 - 18x + 9 + 9y^2 = x^2 + 2x + 1 + y^2$$

$$\Rightarrow 8x^2 - 20x + 8y^2 + 8 = 0$$

$$\Rightarrow x^2 + y^2 - \frac{5}{3}x + 1 = 0$$

\therefore A lies on the circle given by eq (1).

As B and C also follow the same condition, they must lie on the same circle.

\therefore Centre of circumcircle of $\triangle ABC$

$$= \text{Centre of circle given by (1)} = \left(\frac{5}{4}, 0\right)$$

Question463

The ellipse $x^2 + 4y^2 = 4$ is inscribed in a rectangle aligned with the coordinate axes, which in turn is inscribed in another ellipse that

passes through the point (4,0) . Then the equation of the ellipse is :
[2009]

Options:

A. $x^2 + 12y^2 = 16$

B. $4x^2 + 48y^2 = 48$

C. $4x^2 + 64y^2 = 48$

D. $x^2 + 16y^2 = 16$

Answer: B

Solution:

Solution:

The given equation of ellipse is

$$\frac{x^2}{4} + \frac{y^2}{1} = 1$$

So, A = (2, 0) and B = (0, 1)

If PQRS is the rectangle in which it is inscribed, then P = (2, 1)

Let $\frac{x^2}{a^2} + \frac{y^2}{b^2} = 1$ be the ellipse

circumscribing the rectangle PQRS.

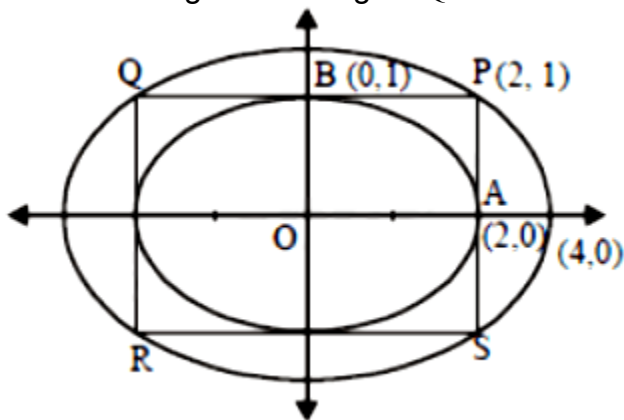

Then it passed through P(2, 1)

$$\therefore \frac{4}{a^2} + \frac{1}{b^2} = 1 \dots\dots (i)$$

Also, given that, it passes through (4,0)

$$\therefore \frac{16}{a^2} + 0 = 1 \Rightarrow a^2 = 16$$

$$\Rightarrow b^2 = 4/3 \quad [\text{putting } a^2 = 16 \text{ in eq } ^n(i)]$$

\therefore The required equation of ellipse is

$$\frac{x^2}{16} + \frac{y^2}{4/3} = 1$$

or $x^2 + 12y^2 = 16$

Question464

The point diametrically opposite to the point $P(1, 0)$ on the circle $x^2 + y^2 + 2x + 4y - 3 = 0$ is [2008]

Options:

A. (3,-4)

B. (-3,4)

C. (-3,-4)

D. (3,4)

Answer: C

Solution:

Solution:

The given circle is $x^2 + y^2 + 2x + 4y - 3 = 0$

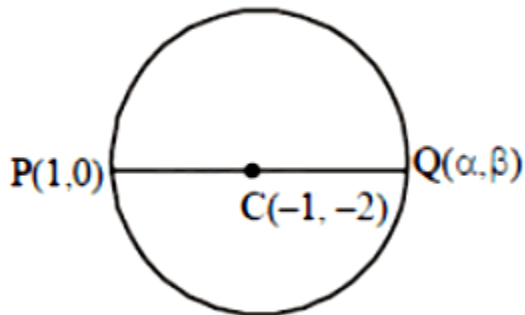

Centre $(-g, -f) = (-1, -2)$

Let $Q(h, k)$ be the point diametrically opposite to the point $P(1, 0)$

then $\frac{1+h}{2} = -1$ and $\frac{0+k}{2} = -2$

$\Rightarrow h = -3, k = -4$

So, Q is $(-3, -4)$

Question465

A parabola has the origin as its focus and the line $x = 2$ as the directrix. Then the vertex of the parabola is at [2008]

Options:

- A. (0,2)
- B. (1,0)
- C. (0,1)
- D. (2,0)

Answer: B

Solution:

Solution:

We know that vertex of a parabola is the mid point of focus and the point

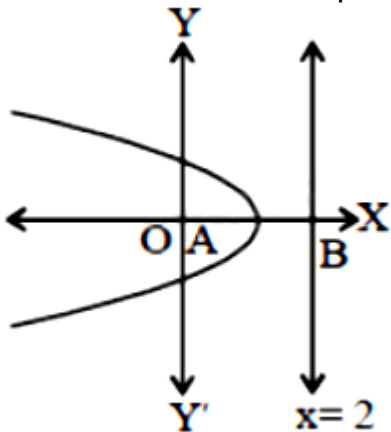

where directrix meets the axis of the parabola. Given that focus is $O(0, 0)$ and directrix meets the axis at $B(2, 0)$

\therefore Vertex of the parabola is $\left(\frac{0+2}{2}, 0 \right) = (1, 0)$

Question466

A focus of an ellipse is at the origin. The directrix is the line $x = 4$ and the eccentricity is $\frac{1}{2}$. Then the length of the semi-major axis is [2008]

Options:

- A. $\frac{8}{3}$
- B. $\frac{2}{3}$
- C. $\frac{4}{3}$
- D. $\frac{5}{3}$

Answer: A

Solution:

Solution:

Perpendicular distance of directrix $x = \pm \frac{a}{e}$ from focus $(\pm ae, 0)$

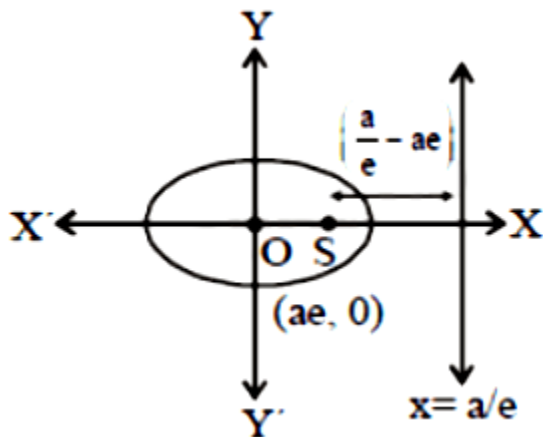

$$= \frac{a}{e} - ae = 4$$

$$\Rightarrow a \left(2 - \frac{1}{2} \right) = 4$$

$$\Rightarrow a = \frac{8}{3}$$

$$\therefore \text{Semi major axis} = 8/3$$

Question467

Consider a family of circles which are passing through the point $(-1,1)$ and are tangent to x -axis. If (h, k) are the coordinate of the centre of the circles, then the set of values of k is given by the interval [2007]

Options:

A. $-\frac{1}{2} \leq k \leq \frac{1}{2}$

B. $k \leq \frac{1}{2}$

C. $0 \leq k \leq \frac{1}{2}$

D. $k \geq \frac{1}{2}$

Answer: D

Solution:

Solution:

Equation of circle whose centre is (h, k) and touch the x -axis

i.e $(x - h)^2 + (y - k)^2 = k^2$

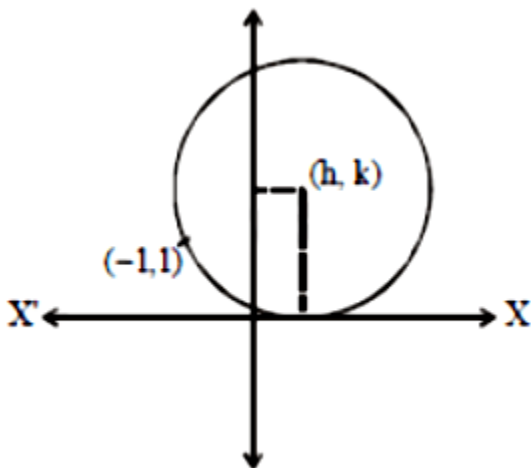

(radius of circle = k because circle is tangent to x -axis)

\therefore Equation of circle passing through $(-1, 1)$

$$\therefore (-1 - h)^2 + (1 - k)^2 = k^2$$

$$\Rightarrow 1 + h^2 + 2h + 1 + k^2 - 2k = k^2$$

$$\Rightarrow h^2 + 2h - 2k + 2 = 0$$

$$D \geq 0$$

$$\therefore (2)^2 - 4 \times 1 \cdot (-2k + 2) \geq 0$$

Question 468

The equation of a tangent to the parabola $y^2 = 8x$ is $y = x + 2$. The point on this line from which the other tangent to the parabola is perpendicular to the given tangent is [2007]

Options:

A. (2,4)

B. (-2,0)

C. (-1,1)

D. (0,2)

Answer: B

Solution:

Solution:

Given that parabola $y^2 = 8x$

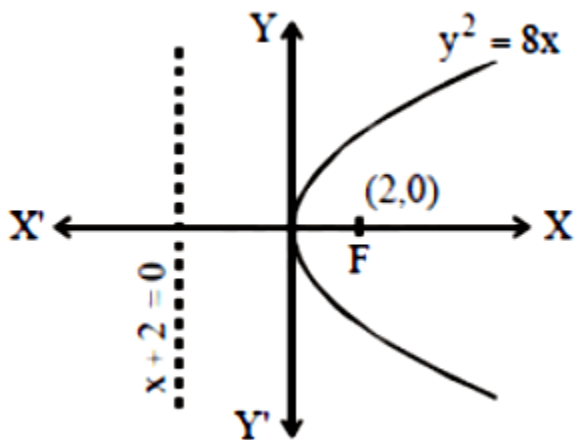

We know that the locus of point of intersection of two perpendicular tangents to a parabola is its directrix. Point must be on the directrix of parabola

\therefore Equation of directrix $x + 2 = 0$

$$\Rightarrow x = -2$$

Hence the point is (-2,0)



Question469

Let C be the circle with centre $(0,0)$ and radius 3 units. The equation of the locus of the mid points of the chords of the circle C that subtend an angle of $\frac{2\pi}{3}$ at its center is

[2006]

Options:

A. $x^2 + y^2 = \frac{3}{2}$

B. $x^2 + y^2 = 1$

C. $x^2 + y^2 = \frac{27}{4}$

D. $x^2 + y^2 = \frac{9}{4}$

Answer: D

Solution:

Solution:

Given that centre of circle be $(0,0)$ and radius is 3 unit Let $M(h, k)$ be the mid point of chord AB where $\angle AOB = \frac{2\pi}{3}$

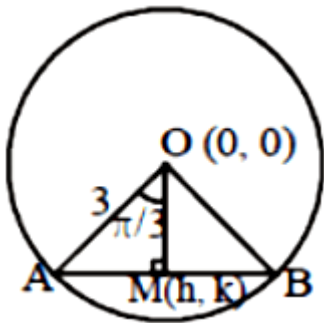

$$\therefore \angle AOM = \frac{\pi}{3}. \text{ Also } OM = 3 \cos \frac{\pi}{3} = \frac{3}{2}$$

$$\Rightarrow \sqrt{h^2 + k^2} = \frac{3}{2} \Rightarrow h^2 + k^2 = \frac{9}{4}$$

$$\therefore \text{Locus of } (h, k) \text{ is } x^2 + y^2 = \frac{9}{4}$$



Question470

If the lines $3x - 4y - 7 = 0$ and $2x - 3y - 5 = 0$ are two diameters of a circle of area 49π square units, the equation of the circle is [2006]

Options:

A. $x^2 + y^2 + 2x - 2y - 47 = 0$

B. $x^2 + y^2 + 2x - 2y - 62 = 0$

C. $x^2 + y^2 - 2x + 2y - 62 = 0$

D. $x^2 + y^2 - 2x + 2y - 47 = 0$

Answer: D

Solution:

Solution:

On solving we get point of intersection of $3x - 4y - 7 = 0$ and $2x - 3y - 5 = 0$ is $(1, -1)$ which is the centre of the circle Area of circle $= \pi r^2 = 49\pi$

\therefore radius $= 7$

\therefore Equation is $(x - 1)^2 + (y + 1)^2 = 49$

$\Rightarrow x^2 + y^2 - 2x + 2y - 47 = 0$

Question471

For the Hyperbola $\frac{x^2}{\cos^2 \alpha} - \frac{y^2}{\sin^2 \alpha} = 1$, which of the following remains constant when α varies =? [2007]

Options:

A. abscissae of vertices

B. abscissae of foci

C. eccentricity

D. directrix

Answer: B

Solution:

Solution:

Given, equation of hyperbola is

$$\frac{x^2}{\cos^2\alpha} - \frac{y^2}{\sin^2\alpha} = 1$$

Compare with equation of hyperbola

$$\frac{x^2}{a^2} - \frac{y^2}{b^2} = 1, \text{ we get } a^2 = \cos^2\alpha \text{ and } b^2 = \sin^2\alpha$$

We know that, $b^2 = a^2(e^2 - 1)$

$$\Rightarrow \sin^2\alpha = \cos^2\alpha(e^2 - 1)$$

$$\Rightarrow \sin^2\alpha + \cos^2\alpha = \cos^2\alpha \cdot e^2$$

$$\Rightarrow e^2 = \sec^2\alpha$$

$$\Rightarrow e = \sec\alpha$$

$$\therefore ae = \cos\alpha \cdot \frac{1}{\cos\alpha} = 1$$

Co-ordinates of foci are $(\pm ae, 0)$ i.e. $(\pm 1, 0)$

Hence, abscissae of foci remain constant when α varies.

Question472

The locus of the vertices of the family of parabolas $y = \frac{a^3x^2}{3} + \frac{a^2x}{2} - 2a$ is
[2006]

Options:

A. $xy = \frac{105}{64}$

B. $xy = \frac{3}{4}$

C. $xy = \frac{35}{16}$



$$D. xy = \frac{64}{105}$$

Answer: A

Solution:

Solution:

Given that family of parabolas is

$$y = \frac{a^3 x^2}{3} + \frac{a^2 x}{2} - 2a$$

$$\Rightarrow y = \frac{a^3}{3} \left(x^2 + \frac{3}{2a} x + \frac{9}{16a^2} \right) - \frac{3a}{16} - 2a$$

$$\Rightarrow y + \frac{35a}{16} = \frac{a^3}{3} \left(x + \frac{3}{4a} \right)^2$$

$$\therefore \text{Vertex of parabola is } \left(\frac{-3}{4a}, \frac{-35a}{16} \right)$$

To find locus of this vertex,

$$x = \frac{-3}{4a} \text{ and } y = \frac{-35a}{16}$$

$$\Rightarrow a = \frac{-3}{4x} \text{ and } a = -\frac{16y}{35}$$

$$\Rightarrow \frac{-3}{4x} = \frac{-16y}{35} \Rightarrow 64xy = 105$$

$$\Rightarrow xy = \frac{105}{64}$$

which is the required equation of locus.

Question473

In an ellipse, the distance between its foci is 6 and minor axis is 8 .

Then its eccentricity is

[2006]

Options:

A. $\frac{3}{5}$

B. $\frac{1}{2}$

C. $\frac{4}{5}$

D. $\frac{1}{\sqrt{5}}$

Answer: A

Solution:

Solution:

Given that distance between foci is

$$2ae = 6 \Rightarrow ae = 3 \text{ and length of minor axis is } 2b = 8 \Rightarrow$$

$$b = 4$$

$$\text{we know that } b^2 = a^2(1 - e^2)$$

$$\Rightarrow 16 = a^2 - a^2e^2 \Rightarrow a^2 = 16 + 9 = 25 \Rightarrow a = 5$$

$$e = \frac{3}{a} = \frac{3}{5}$$

Question474

If a circle passes through the point (a, b) and cuts the circle $x^2 + y^2 = p^2$ orthogonally, then the equation of the locus of its centre is [2005]

Options:

A. $x^2 + y^2 - 3ax - 4by + (a^2 + b^2 - p^2) = 0$

B. $2ax + 2by - (a^2 - b^2 + p^2) = 0$

C. $x^2 + y^2 - 2ax - 3by + (a^2 - b^2 - p^2) = 0$

D. $2ax + 2by - (a^2 + b^2 + p^2) = 0$

Answer: D

Solution:

Solution:

Let the centre variable circle be (α, β)

\therefore It cuts the circle $x^2 + y^2 = p^2$ orthogonally

\therefore Using $2g_1g_2 + 2f_1f_2 = c_1 + c_2$, we get

$$2(-\alpha) \times 0 + 2(-\beta) \times 0 = c_1 - p^2$$

$$\Rightarrow c_1 = p^2$$

Let equation of circle is $x^2 + y^2 - 2\alpha x - 2\beta y + p^2 = 0$

\therefore It passes through (a, b)

$$\Rightarrow a^2 + b^2 - 2\alpha a - 2\beta b + p^2 = 0$$

\therefore Locus of (α, β) is

$$\therefore 2ax + 2by - (a^2 + b^2 + p^2) = 0$$

Question475

If the pair of lines $ax^2 + 2(a + b)xy + by^2 = 0$ lie along diameters of a circle and divide the circle into four sectors such that the area of one of the sectors is thrice the area of another sector then

[2005]

Options:

A. $3a^2 - 10ab + 3b^2 = 0$

B. $3a^2 - 2ab + 3b^2 = 0$

C. $3a^2 + 10ab + 3b^2 = 0$

D. $3a^2 + 2ab + 3b^2 = 0$

Answer: D

Solution:

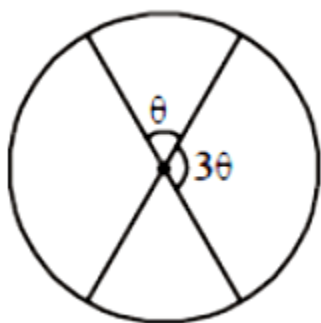

Given that area of one sector

= $3 \times$ area of another sector

\Rightarrow Angle at centre by one sector = $3 \times$ angle at centre by another sector

Let one angle be θ then other = 3θ

Clearly $\theta + 3\theta = 180 \Rightarrow \theta = 45^\circ$ (Linear pair)

\therefore Angle between the diameters represented by pair of equation

$ax^2 + 2(a+b)xy + by^2 = 0$ is 45°

$$\text{Using } \tan \theta = \frac{2\sqrt{h^2 - ab}}{a+b}$$

$$\text{we get, } \tan 45^\circ = \frac{2\sqrt{(a+b)^2 - ab}}{a+b}$$

$$\Rightarrow 1 = \frac{2\sqrt{a^2 + b^2 + ab}}{a+b}$$

$$\Rightarrow (a+b)^2 = 4(a^2 + b^2 + ab)$$

$$\Rightarrow a^2 + b^2 + 2ab = 4a^2 + 4b^2 + 4ab$$

$$\Rightarrow 3a^2 + 3b^2 + 2ab = 0$$

Question 476

If the circles $x^2 + y^2 + 2ax + cy + a = 0$ and $x^2 + y^2 - 3ax + dy - 1 = 0$ intersect in two distinct points P and Q then the line $5x + by - a = 0$ passes through P and Q for [2005]

Options:

- A. exactly one value of a
- B. no value of a
- C. infinitely many values of a
- D. exactly two values of a

Answer: B

Solution:

Solution:

Given that

$$s_1 = x^2 + y^2 + 2ax + cy + a = 0$$

$$s_2 = x^2 + y^2 - 3ax + dy - 1 = 0$$

Equation of common chord PQ of circles s_1 and s_2 is given by $s_1 - s_2 = 0$

$$\Rightarrow 5ax + (c-d)y + a + 1 = 0$$

Given that $5x + by - a = 0$ passes through P and Q
 \therefore The two equations should represent the same line

$$\Rightarrow \frac{a_1}{a_2} = \frac{b_1}{b_2} = \frac{c_1}{c_2}$$

$$\Rightarrow \frac{a}{1} = \frac{c-d}{b} = \frac{a+1}{-a} \Rightarrow a+1 = -a^2$$

$$a^2 + a + 1 = 0 \quad [\because D = -3]$$

\therefore No real value of a

Question477

Let P be the point (1,0) and Q a point on the locus $y^2 = 8x$. The locus of mid point of PQ is
[2005]

Options:

A. $y^2 - 4x + 2 = 0$

B. $y^2 + 4x + 2 = 0$

C. $x^2 + 4y + 2 = 0$

D. $x^2 - 4y + 2 = 0$

Answer: A

Solution:

Solution:

Given P = (1, 0), let Q = (h, k)

Since Q lies on $y^2 = 8x$

$$k^2 = 8h$$

Let (α, β) be the midpoint of PQ

$$\therefore \alpha = \frac{h+1}{2}, \beta = \frac{k+0}{2}$$

$$2\alpha - 1 = h \quad 2\beta = k$$

Putting value of h and k in (i)

$$(2\beta)^2 = 8(2\alpha - 1) \Rightarrow \beta^2 = 4\alpha - 2$$

$$\Rightarrow y^2 - 4x + 2 = 0$$

Question478

A circle touches the x - axis and also touches the circle with centre at (0,3) and radius 2 . The locus of the centre of the circle is [2005]

Options:

- A. an ellipse
- B. a circle
- C. a hyperbola
- D. a parabola

Answer: D

Solution:

Solution:

Equation of circle with centre (0,3) and radius 2 is $x^2 + (y - 3)^2 = 4$

Let locus of the centre of the variable circle is (α, β)

\therefore It touches x -axis.

\therefore It's equation is $(x - \alpha)^2 + (y - \beta)^2 = \beta^2$

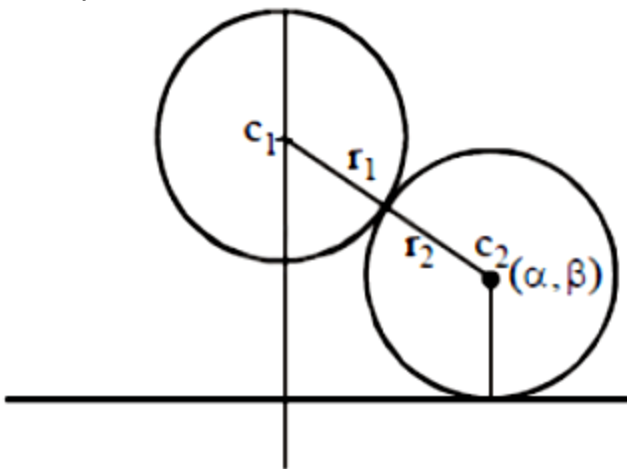

Circle touch externally $\Rightarrow c_1 c_2 = r_1 + r_2$

$$\therefore \sqrt{\alpha^2 + (\beta - 3)^2} = 2 + \beta$$

$$\alpha^2 + (\beta - 3)^2 = \beta^2 + 4 + 4\beta$$

$$\alpha^2 + \beta^2 - 6\beta + 9 = \beta^2 + 4 + 4\beta$$

$$\Rightarrow \alpha^2 = 10(\beta - 1/2)$$

$$= \text{Locus is } x^2 = 10\left(y - \frac{1}{2}\right)$$

Which is equation of parabola.

Question479

An ellipse has OB as semi minor axis, F and F' its foci and the angle $\angle FBF'$ is a right angle. Then the eccentricity of the ellipse is [2005]

Options:

A. $\frac{1}{\sqrt{2}}$

B. $\frac{1}{2}$

C. $\frac{1}{4}$

D. $\frac{1}{\sqrt{3}}$

Answer: A

Solution:

Solution:

Given that $\angle FBF' = 90^\circ$

$$\Rightarrow FB^2 + F'B^2 = FF'^2$$

$$\therefore (\sqrt{a^2e^2 + b^2})^2 + (\sqrt{a^2e^2 + b^2})^2 = (2ae)^2$$

$$\Rightarrow 2(a^2e^2 + b^2) = 4a^2e^2 \Rightarrow e^2 = \frac{b^2}{a^2} \dots (1)$$

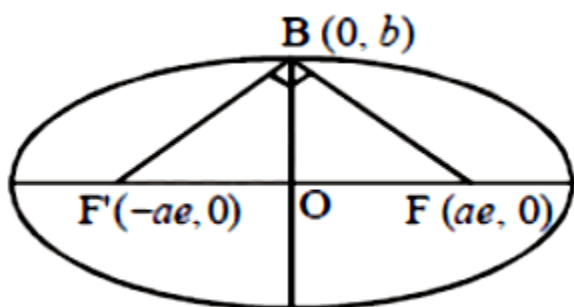

We know that $e^2 = 1 - b^2/a^2 = 1 - e^2$ [from (i)]

$$\Rightarrow 2e^2 = 1, e = \frac{1}{\sqrt{2}}$$

Question480

The locus of a point $P(\alpha, \beta)$ moving under the condition that the line $y = \alpha x + \beta$ is a tangent to the hyperbola $\frac{x^2}{a^2} - \frac{y^2}{b^2} = 1$ is

[2005]

Options:

- A. an ellipse
- B. a circle
- C. a parabola
- D. a hyperbola

Answer: D

Solution:

Solution:

We know that tangent to the hyperbola $\frac{x^2}{a^2} - \frac{y^2}{b^2} = 1$ is

$$y = mx \pm \sqrt{a^2 m^2 - b^2}$$

Given that $y = \alpha x + \beta$ is the tangent of hyperbola.

$$\Rightarrow m = \alpha \text{ and } a^2 m^2 - b^2 = \beta^2$$

$$\therefore a^2 \alpha^2 - b^2 = \beta^2$$

Locus is $a^2 x^2 - y^2 = b^2$ which is hyperbola.

Question481

If a circle passes through the point (a, b) and cuts the circle $x^2 + y^2 = 4$ orthogonally, then the locus of its centre is



[2004]

Options:

A. $2ax - 2by - (a^2 + b^2 + 4) = 0$

B. $2ax + 2by - (a^2 + b^2 + 4) = 0$

C. $2ax - 2by + (a^2 + b^2 + 4) = 0$

D. $2ax + 2by + (a^2 + b^2 + 4) = 0$

Answer: B

Solution:

Solution:

Let the equation of circle is

$$x^2 + y^2 + 2gx + 2fy + c = 0 \dots\dots (1)$$

It passes through (a, b)

$$\therefore a^2 + b^2 + 2ga + 2fb + c = 0 \dots\dots$$

Circle (1) cuts $x^2 + y^2 = 4$ orthogonally

Two circles intersect orthogonally if $2g_1g_2 + 2ff_2 = c_1 + c_2$

$$\therefore 2(g \times 0 + f \times 0) = c - 4 \Rightarrow c = 4 \dots\dots(2)$$

$$a^2 + b^2 + 2ga + 2fb + 4 = 0$$

$$\therefore \text{from (2) } a^2 + b^2 + 2ga + 2fb + 4 = 0$$

\therefore Locus of centre $(-g, -f)$ is

$$a^2 + b^2 - 2ax - 2by + 4 = 0$$

$$\text{or } 2ax + 2by = a^2 + b^2 + 4$$

Question482

A variable circle passes through the fixed point A(p, q) and touches x - axis. The locus of the other end of the diameter through A is

[2004]

Options:

A. $(y - q)^2 = 4px$

B. $(x - q)^2 = 4py$

C. $(y - p)^2 = 4qx$

D. $(x - p)^2 = 4qy$

Answer: D

Solution:

Solution:

Let the variable circle be $x^2 + y^2 + 2gx + 2fy + c = 0 \dots (1)$

Since it passes through (p, q)

$$\therefore p^2 + q^2 + 2gp + 2fq + c = 0 \dots (2)$$

Circle (1) touches x-axis, $\therefore g^2 - c = 0 \Rightarrow c = g^2$. From (2)

$$p^2 + q^2 + 2gp + 2fq + g^2 = 0$$

Let the other end of diameter through (p, q) be (h, k) , then

$$\frac{h+p}{2} = -g \text{ and } \frac{k+q}{2} = -f \text{ Putting value of } g \text{ and } f \text{ in (3), we get}$$

$$p^2 + q^2 + 2p\left(-\frac{h+p}{2}\right) + 2q\left(-\frac{k+q}{2}\right) + \left(\frac{h+p}{2}\right)^2 = 0$$

$$\Rightarrow h^2 + p^2 - 2hp - 4kq = 0$$

$$\therefore \text{locus of } (h, k) \text{ is } x^2 + p^2 - 2xp - 4yq = 0$$

$$\Rightarrow (x - p)^2 = 4qy$$

Question483

If the lines $2x + 3y + 1 = 0$ and $3x - y - 4 = 0$ lie along diameter of a circle of circumference 10π , then the equation of the circle is [2004]

Options:

A. $x^2 + y^2 + 2x - 2y - 23 = 0$

B. $x^2 + y^2 - 2x - 2y - 23 = 0$

C. $x^2 + y^2 + 2x + 2y - 23 = 0$

D. $x^2 + y^2 - 2x + 2y - 23 = 0$

Answer: D

Solution:

Solution:

Two diameters are along

$$2x + 3y + 1 = 0 \text{ and } 3x - y - 4 = 0$$

On solving we get centre (1,-1)

$$\text{Circumference of circle} = 2\pi r = 10\pi$$

$$\therefore r = 5$$

$$\text{Required circle is, } (x-1)^2 + (y+1)^2 = 5^2$$

$$\Rightarrow x^2 + y^2 - 2x + 2y - 23 = 0$$

Question484

Intercept on the line $y = x$ by the circle $x^2 + y^2 - 2x = 0$ is AB. Equation of the circle on AB as a diameter is [2004]

Options:

A. $x^2 + y^2 + x - y = 0$

B. $x^2 + y^2 - x + y = 0$

C. $x^2 + y^2 + x + y = 0$

D. $x^2 + y^2 - x - y = 0$

Answer: D

Solution:

Solution:

Solving $y = x$ and the circle

$$x^2 + y^2 - 2x = 0, \text{ we get}$$

$$x = 0, y = 0 \text{ and } x = 1, y = 1$$

\therefore Extremities of diameter of the required circle are A(0, 0) and B(1, 1). Hence, the equation of circle is

$$(x-0)(x-1) + (y-0)(y-1) = 0$$

$$\Rightarrow x^2 + y^2 - x - y = 0$$

Question485

If $a \neq 0$ and the line $2bx + 3cy + 4d = 0$ passes through the points of intersection of the parabolas $y^2 = 4ax$ and $x^2 = 4ay$, then
[2004]

Options:

A. $d^2 + (3b - 2c)^2 = 0$

B. $d^2 + (3b + 2c)^2 = 0$

C. $d^2 + (2b - 3c)^2 = 0$

D. $d^2 + (2b + 3c)^2 = 0$

Answer: D

Solution:

Solution:

Solving equations of parabolas

$y^2 = 4ax$ and $x^2 = 4ay$, we get $(0,0)$ and $(4a, 4a)$

Putting in the given equation of line

$2bx + 3cy + 4d = 0$, we get

$d = 0$ and $2b + 3c = 0$

$\Rightarrow d^2 + (2b + 3c)^2 = 0$

Question486

The eccentricity of an ellipse, with its centre at the origin, is $\frac{1}{2}$. If one of the directrices is $x = 4$, then the equation of the ellipse is:
[2004]

Options:

A. $4x^2 + 3y^2 = 1$

B. $3x^2 + 4y^2 = 12$

C. $4x^2 + 3y^2 = 12$

D. $3x^2 + 4y^2 = 1$

Answer: B

Solution:

Solution:

Given that $e = \frac{1}{2}$. Directrix, $x = \frac{a}{e} = 4$

$$\therefore a = 4 \times \frac{1}{2} = 2 \quad \therefore b = 2 \sqrt{1 - \frac{1}{4}} = \sqrt{3}$$

Equation of ellipse is

$$\frac{x^2}{4} + \frac{y^2}{3} = 1 \Rightarrow 3x^2 + 4y^2 = 12$$

Question487

If the two circles $(x - 1)^2 + (y - 3)^2 = r^2$ and $x^2 + y^2 - 8x + 2y + 8 = 0$ intersect in two distinct point, then [2003]

Options:

A. $r > 2$

B. $2 < r < 8$

C. $r < 2$

D. $r = 2$.

Answer: B

Solution:

Solution:

\therefore Given two circles intersect at two points

$$\therefore |r_1 - r_2| < C_1 C_2$$

$$\Rightarrow r - 3 < 5 \Rightarrow 0 < r < 8 \quad \dots\dots (1)$$

and $r_1 + r_2 > C_1 C_2$, $r + 3 > 5 \Rightarrow r > 2$ (2)

From (1) and (2), $2 < r < 8$.

Question488

The lines $2x - 3y = 5$ and $3x - 4y = 7$ are diameters of a circle having area as 154 sq.units. Then the equation of the circle is [2003]

Options:

A. $x^2 + y^2 - 2x + 2y = 62$

B. $x^2 + y^2 + 2x - 2y = 62$

C. $x^2 + y^2 + 2x - 2y = 47$

D. $x^2 + y^2 - 2x + 2y = 47$.

Answer: D

Solution:

Solution:

Area of circle $= \pi r^2 = 154 \Rightarrow r = 7$

For centre, solving equation

$2x - 3y = 5$ & $3x - 4y = 7$ we get $x = 1, y = -1$

\therefore centre $= (1, -1)$

Equation of circle, $(x - 1)^2 + (y + 1)^2 = 7^2$

$x^2 + y^2 - 2x + 2y = 47$

Question489

The normal at the point $(bt_1^2, 2bt_1)$ on a parabola meets the parabola again in the point $(bt_2^2, 2bt_2)$, then [2003]

Options:

A. $t_2 = t_1 + \frac{2}{t_1}$

B. $t_2 = -t_1 - \frac{2}{t_1}$

C. $t_2 = -t_1 + \frac{2}{t_1}$

D. $t_2 = t_1 - \frac{2}{t_1}$

Answer: B

Solution:

Solution:

Equation of the normal to a parabola $y^2 = 4bx$ at point $(bt_1^2, 2bt_1)$ is

$$y = -t_1x + 2bt_1 + bt_1^3$$

Given that, it also passes through $(bt_2^2, 2bt_2)$ then

$$2bt_2 = -t_1bt_2^2 + 2bt_1 + bt_1^3$$

$$\Rightarrow 2t_2 - 2t_1 = -t_1(t_2^2 - t_1^2)$$

$$\Rightarrow 2(t_2 - t_1) = -t_1(t_2 + t_1)(t_2 - t_1)$$

$$\Rightarrow 2 = -t_1(t_2 + t_1) \Rightarrow t_2 + t_1 = -\frac{2}{t_1}$$

$$\Rightarrow t_2 = -t_1 - \frac{2}{t_1}$$

Question490

The foci of the ellipse $\frac{x^2}{16} + \frac{y^2}{b^2} = 1$ and the hyperbola $\frac{x^2}{144} - \frac{y^2}{81} = \frac{1}{25}$

coincide. Then the value of b^2 is

[2003]

Options:

A. 9

B. 1

C. 5

D. 7

Answer: D

Solution:

Solution:

$$\frac{x^2}{144} - \frac{y^2}{81} = \frac{1}{25}$$

$$a = \sqrt{\frac{144}{25}} = \frac{12}{5}, b = \sqrt{\frac{81}{25}} = \frac{9}{5},$$

$$e = \sqrt{1 + \frac{81}{144}} = \frac{15}{12} = \frac{5}{4}$$

$$\therefore \text{Foci} = (\pm ae, 0) = (\pm 3, 0)$$

\therefore foci of ellipse = foci of hyperbola

\therefore for ellipse $ae = 3$ but $a = 4$

$$\therefore e = \frac{3}{4} \text{ Then, } b^2 = a^2(1 - e^2)$$

$$\Rightarrow b^2 = 16 \left(1 - \frac{9}{16}\right) = 7$$

Question491

If the chord $y = mx + 1$ of the circle $x^2 + y^2 = 1$ subtends an angle of measure 45° at the major segment of the circle then value of m is [2002]

Options:

A. $2 \pm \sqrt{2}$

B. $-2 \pm \sqrt{2}$

C. $-1 \pm \sqrt{2}$

D. none of these

Answer: C

Solution:

Solution:

Given equation of circle $x^2 + y^2 = 1 = (1)^2$

$$\Rightarrow x^2 + y^2 = (y - mx)^2$$

$$\Rightarrow x^2 = m^2 x^2 - 2mxy;$$

$$\Rightarrow x^2(1 - m^2) + 2mxy = 0.$$

Which represents the pair of lines between which the angle is 45° . $\tan 45 = \pm \frac{2\sqrt{m^2 - 0}}{1 - m^2} = \frac{\pm 2m}{1 - m^2}$

$$\Rightarrow 1 - m^2 = \pm 2m \Rightarrow m^2 \pm 2m - 1 = 0$$

$$\Rightarrow m = \frac{-2 \pm \sqrt{4 + 4}}{2} = \frac{-2 \pm 2\sqrt{2}}{2} = -1 \pm \sqrt{2}$$

Question492

The centres of a set of circles, each of radius 3, lie on the circle $x^2 + y^2 = 25$. The locus of any point in the set is [2002]

Options:

A. $4 \leq x^2 + y^2 \leq 64$

B. $x^2 + y^2 \leq 25$

C. $x^2 + y^2 \geq 25$

D. $3 \leq x^2 + y^2 \leq 9$

Answer: A

Solution:

Solution:

\because The centre C of circle of radius 3 lies on circle of radius 5 . Let P(x, y) in the smaller circle.

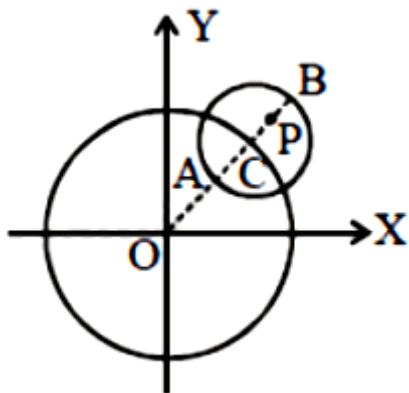

we should have

$$OA \leq OP \leq OB$$

$$\Rightarrow (5-3) \leq \sqrt{x^2+y^2} \leq 5+3$$

$$\Rightarrow 4 \leq x^2+y^2 \leq 64$$

Question493

The centre of the circle passing through $(0,0)$ and $(1,0)$ and touching the circle $x^2 + y^2 = 9$ is
[2002]

Options:

A. $\left(\frac{1}{2}, \frac{1}{2}\right)$

B. $\left(\frac{3}{2}, \frac{1}{2}\right)$

C. $\left(\frac{1}{2}, \frac{3}{2}\right)$

D. $\left(\frac{1}{2}, -\sqrt{2}\right)$

Answer: B

Solution:



Let the required circle be

$$x^2 + y^2 + 2gx + 2fy + c = 0$$

Since it passes through (0,0) and (1,0) On putting these values, we get

$$\Rightarrow c = 0 \text{ and } g = -\frac{1}{2}$$

Points (0,0) and (1,0) lie inside the circle $x^2 + y^2 = 9$, so two circles touch internally

$$\Rightarrow c_1 c_2 = r_1 - r_2$$

$$\therefore \sqrt{g^2 + f^2} = 3 - \sqrt{g^2 + f^2} \Rightarrow \sqrt{g^2 + f^2} = \frac{3}{2}$$

Squaring both side, we get

$$\Rightarrow f^2 = \frac{9}{4} - \frac{1}{4} = 2 \quad \therefore f = \pm\sqrt{2}$$

Hence, the centres of required circle are $\left(\frac{1}{2}, \sqrt{2}\right)$ or $\left(\frac{1}{2}, -\sqrt{2}\right)$

Question494

The equation of a circle with origin as a centre and passing through equilateral triangle whose median is of length 3 a is [2002]

Options:

A. $x^2 + y^2 = 9a^2$

B. $x^2 + y^2 = 16a^2$

C. $x^2 + y^2 = 4a^2$

D. $x^2 + y^2 = a^2$

Answer: C

Solution:

Solution:

Let ABC be an equilateral triangle, whose median is AD.

In equilateral triangle median is also altitude

So, $AD \perp BC$ Given $AD = 3a$

Let $AB = BC = AC = x$. In $\triangle ABD$, $AB^2 = AD^2 + BD^2$

$$\Rightarrow x^2 = 9a^2 + \left(\frac{x^2}{4}\right) \quad \frac{3}{4}x^2 = 9a^2 \Rightarrow x^2 = 12a^2$$

In $\triangle OBD$, $OB^2 = OD^2 + BD^2$

$$\Rightarrow r^2 = (3a - r)^2 + \frac{x^2}{4}$$

$$\Rightarrow r^2 = 9a^2 - 6ar + r^2 + 3a^2$$

$$\Rightarrow 6ar = 12a^2$$

$$\Rightarrow r = 2a$$

So equation of circle is $x^2 + y^2 = 4a^2$

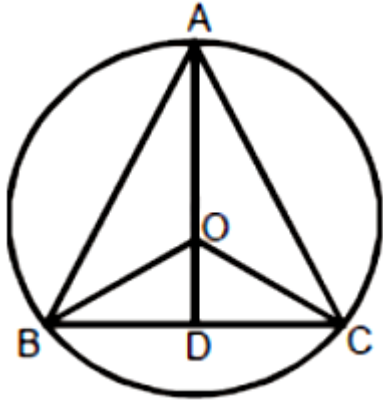

Question495

Two common tangents to the circle $x^2 + y^2 = 2a^2$ and parabola $y^2 = 8ax$ are

[2002]

Options:

A. $x = \pm(y + 2a)$

B. $y = \pm(x + 2a)$

C. $x = \pm(y + a)$

D. $y = \pm(x + a)$

Answer: B

Solution:

Solution:

The equation of any tangent to the parabola $y^2 = 8ax$ is $y = mx + \frac{2a}{m}$ (i)

If (i) is also a tangent to the circle, $x^2 + y^2 = 2a^2$ then,

$$\sqrt{2}a = \pm \frac{2a}{m\sqrt{m^2+1}}$$

$$\Rightarrow m^2(1+m^2) = 2 \Rightarrow (m^2+2)(m^2-1) = 0 \Rightarrow m = \pm 1.$$

Putting the value of m in eqn (i), we get

$$y = \pm(x + 2a)$$
